

Skill 01

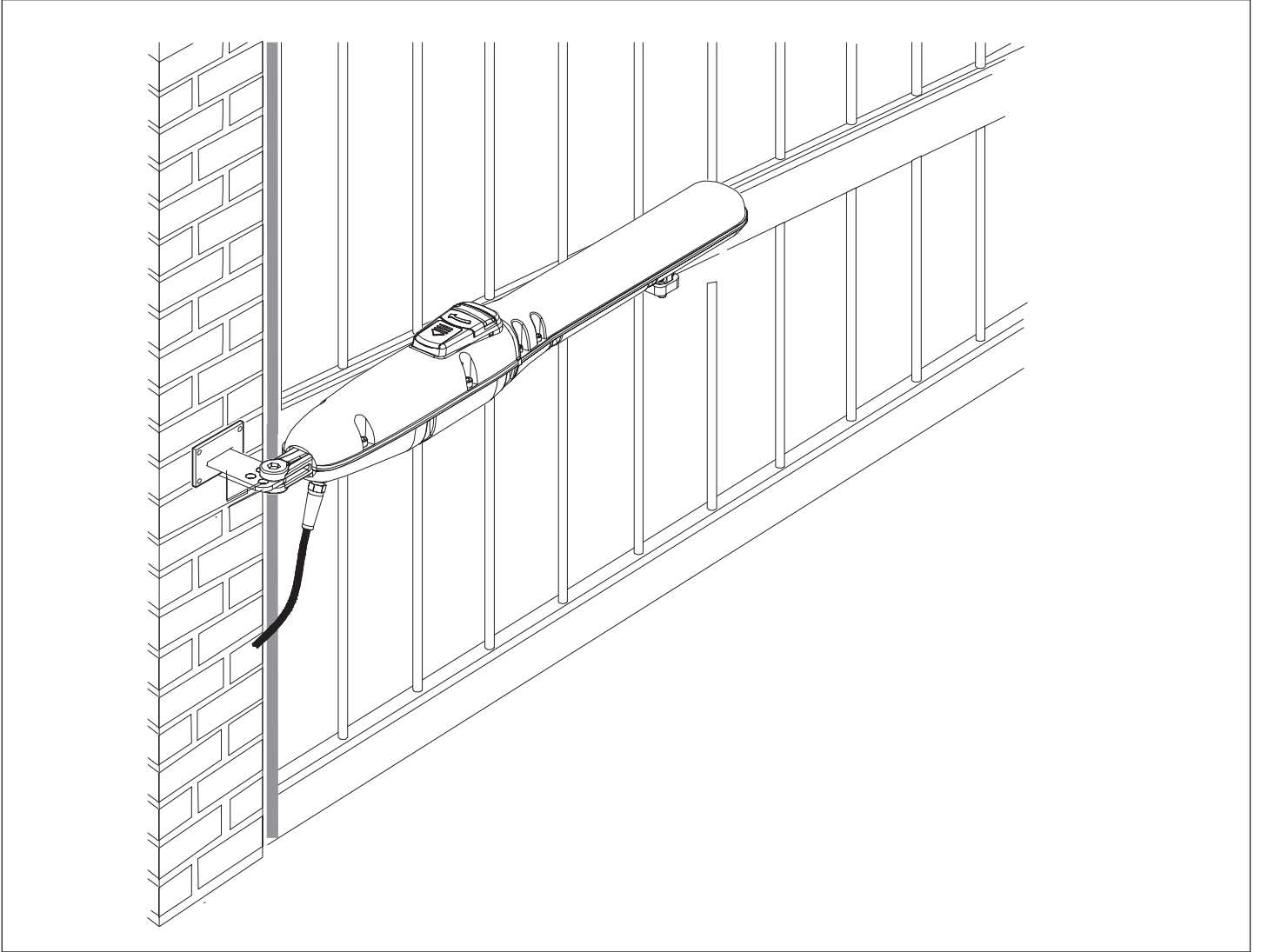

GENIUS

COMPANY
WITH QUALITY SYSTEM
CERTIFIED BY DNV
=ISO 9001/2000=

CE

AVVERTENZE PER L'INSTALLATORE

OBBLIGHI GENERALI PER LA SICUREZZA

- ATTENZIONE! È importante per la sicurezza delle persone seguire attentamente tutta l'istruzione. Una errata installazione o un errato uso del prodotto può portare a gravi danni alle persone.**
- Leggere attentamente le istruzioni prima di iniziare l'installazione del prodotto.
- I materiali dell'imballaggio (plastica, polistirolo, ecc.) non devono essere lasciati alla portata dei bambini in quanto potenziali fonti di pericolo.
- Conservare le istruzioni per riferimenti futuri.
- Questo prodotto è stato progettato e costruito esclusivamente per l'utilizzo indicato in questa documentazione. Qualsiasi altro utilizzo non espressamente indicato potrebbe pregiudicare l'integrità del prodotto e/o rappresentare fonte di pericolo.
- GENIUS declina qualsiasi responsabilità derivata dall'uso improprio o diverso da quello per cui l'automatismo è destinato.
- Non installare l'apparecchio in atmosfera esplosiva: la presenza di gas o fumi infiammabili costituisce un grave pericolo per la sicurezza.
- Gli elementi costruttivi meccanici devono essere in accordo con quanto stabilito dalle Norme EN 12604 e EN 12605.
Per i Paesi extra-CEE, oltre ai riferimenti normativi nazionali, per ottenere un livello di sicurezza adeguato, devono essere seguite le Norme sopra riportate.
- GENIUS non è responsabile dell'inosservanza della Buona Tecnica nella costruzione delle chiusure da motorizzare, nonché delle deformazioni che dovessero intervenire nell'utilizzo.
- L'installazione deve essere effettuata nell'osservanza delle Norme EN 12453 e EN 12445. Il livello di sicurezza dell'automazione deve essere C+E.
- Prima di effettuare qualsiasi intervento sull'impianto, togliere l'alimentazione elettrica.
- Prevedere sulla rete di alimentazione dell'automazione un interruttore onnipolare con distanza d'apertura dei contatti uguale o superiore a 3 mm. È consigliabile l'uso di un magnetotermico da 6A con interruzione onnipolare.
- Verificare che a monte dell'impianto visia un interruttore differenziale con soglia da 0,03 A.
- Verificare che l'impianto di terra sia realizzato a regola d'arte e collegarvi le parti metalliche della chiusura.
- L'automazione dispone di una sicurezza intrinseca antischiacciamento costituita da un controllo di coppia. E' comunque necessario verificarne la soglia di intervento secondo quanto previsto dalle Norme indicate al punto 10.
- I dispositivi di sicurezza (norma EN 12978) permettono di proteggere eventuali aree di pericolo da **Rischi meccanici di movimento**, come ad Es. schiacciamento, convogliamento, cesoiamento.
- Per ogni impianto è consigliato l'utilizzo di almeno una segnalazione luminosa nonché di un cartello di segnalazione fissato adeguatamente sulla struttura dell'infixso, oltre ai dispositivi citati al punto "16".
- GENIUS declina ogni responsabilità ai fini della sicurezza e del buon funzionamento dell'automazione, in caso vengano utilizzati componenti dell'impianto non di produzione GENIUS.
- Per la manutenzione utilizzare esclusivamente parti originali GENIUS.
- Non eseguire alcuna modifica sui componenti facenti parte del sistema d'automazione.
- L'installatore deve fornire tutte le informazioni relative al funzionamento manuale del sistema in caso di emergenza e consegnare all'Utente utilizzatore dell'impianto il libretto d'avvertenze allegato al prodotto.
- Non permettere ai bambini o persone di sostare nelle vicinanze del prodotto durante il funzionamento.
- Tenere fuori dalla portata dei bambini radiocomandi o qualsiasi altro datore di impulso, per evitare che l'automazione possa essere azionata involontariamente.
- Il transito tra le ante deve avvenire solo a cancello completamente aperto.
- L'Utente utilizzatore deve astenersi da qualsiasi tentativo di riparazione o d'intervento diretto e rivolgersi solo a personale qualificato.
- Tutto quello che non è previsto espressamente in queste istruzioni non è permesso**

IMPORTANT NOTICE FOR THE INSTALLER

GENERAL SAFETY REGULATIONS

- ATTENTION! To ensure the safety of people, it is important that you read all the following instructions. Incorrect installation or incorrect use of the product could cause serious harm to people.**
- Carefully read the instructions before beginning to install the product.
- Do not leave packing materials (plastic, polystyrene, etc.) within reach of children as such materials are potential sources of danger.
- Store these instructions for future reference.
- This product was designed and built strictly for the use indicated in this documentation. Any other use, not expressly indicated here, could compromise the good condition/operation of the product and/or be a source of danger.
- GENIUS declines all liability caused by improper use or use other than that for which the automated system was intended.
- Do not install the equipment in an explosive atmosphere: the presence of inflammable gas or fumes is a serious danger to safety.

- The mechanical parts must conform to the provisions of Standards EN 12604 and EN 12605.
For non-EU countries, to obtain an adequate level of safety, the Standards mentioned above must be observed, in addition to national legal regulations.
- GENIUS is not responsible for failure to observe Good Technique in the construction of the closing elements to be motorised, or for any deformation that may occur during use.
- The installation must conform to Standards EN 12453 and EN 12445. The safety level of the automated system must be C+E.
- Before attempting any job on the system, cut out electrical power.
- The mains power supply of the automated system must be fitted with an all-pole switch with contact opening distance of 3mm or greater. Use of a 6A thermal breaker with all-pole circuit break is recommended.
- Make sure that a differential switch with threshold of 0.03 A is fitted upstream of the system.
- Make sure that the earthing system is perfectly constructed, and connect metal parts of the means of the closure to it.
- The automated system is supplied with an intrinsic anti-crushing safety device consisting of a torque control. Nevertheless, its tripping threshold must be checked as specified in the Standards indicated at point 10.
- The safety devices (EN 12978 standard) protect any danger areas against **mechanical movement Risks**, such as crushing, dragging, and shearing.
- Use of at least one indicator-light is recommended for every system, as well as a warning sign adequately secured to the frame structure, in addition to the devices mentioned at point "16".
- GENIUS declines all liability as concerns safety and efficient operation of the automate system, if system components not produced by GENIUS are used.
- For maintenance, strictly use original parts by GENIUS.
- Do not in any way modify the components of the automate system.
- The installer shall supply all information concerning manual operation of the system in case of an emergency, and shall hand over to the user the warnings handbook supplied with the product.
- Do not allow children or adults to stay near the product while it is operating.
- Keep remote controls or other pulse generators away from children, to prevent the automated system from being activated involuntarily.
- Transit through the leaves is allowed only when the gate is fully open.
- The user must not attempt any kind of repair or direct action whatever and contact qualified personnel only.
- Anything not expressly specified in these instructions is not permitted.**

CONSIGNES POUR L'INSTALLATEUR

RÈGLES DE SÉCURITÉ

- ATTENTION! Il est important, pour la sécurité des personnes, de suivre à la lettre toutes les instructions. Une installation erronée ou un usage erroné du produit peut entraîner de graves conséquences pour les personnes.**
- Lire attentivement les instructions avant d'installer le produit.
- Les matériaux d'emballage (matière plastique, polystyrène, etc.) ne doivent pas être laissés à la portée des enfants car ils constituent des sources potentielles de danger.
- Conserver les instructions pour les références futures.
- Ce produit a été conçu et construit exclusivement pour l'usage indiqué dans cette documentation. Toute autre utilisation non expressément indiquée pourrait compromettre l'intégrité du produit et/ou représenter une source de danger.
- GENIUS décline toute responsabilité qui dériverait d'usage impropre ou différent de celui auquel l'automatisme est destiné.
- Ne pas installer l'appareil dans une atmosphère explosive: la présence de gaz ou de fumées inflammables constitue un grave danger pour la sécurité.
- Les composants mécaniques doivent répondre aux prescriptions des Normes EN 12604 et EN 12605.
Pour les Pays extra-CEE, l'obtention d'un niveau de sécurité approprié exige non seulement le respect des normes nationales, mais également le respect des Normes susmentionnées.
- GENIUS n'est pas responsable du non-respect de la Bonne Technique dans la construction des fermetures à motoriser, ni des déformations qui pourraient intervenir lors de l'utilisation.
- L'installation doit être effectuée conformément aux Normes EN 12453 et EN 12445. Le niveau de sécurité de l'automatisme doit être C+E.
- Couper l'alimentation électrique avant toute intervention sur l'installation.
- Prévoir, sur le secteur d'alimentation de l'automatisme, un interrupteur onnipolaire avec une distance d'ouverture des contacts égale ou supérieure à 3 mm. On recommande d'utiliser un magnétothermique de 6A avec interruption onnipolaire.
- Vérifier qu'il y ait, en amont de l'installation, un interrupteur différentiel avec un seuil de 0,03 A.
- Vérifier que la mise à terre est réalisée selon les règles de l'art et y connecter les pièces métalliques de la fermeture.
- L'automatisme dispose d'une sécurité intrinsèque anti-écrasement, formée d'un contrôle du couple. Il est toutefois nécessaire d'en vérifier le seuil d'intervention suivant les prescriptions des Normes indiquées au point 10.
- Les dispositifs de sécurité (norme EN 12978) permettent de protéger des zones éventuellement dangereuses contre les **Risques mécaniques du mouvement**, comme l'écrasement, l'acheminement, le cisaillement.

AUTOMATED SYSTEM SKILL

The SKILL automated system for swing gates is an electro-mechanical operator transmitting motion to the leaf via a planetary reduction and worm screw system.

The SKILL operator is suitable for every installation requirement.

It is available both in non-reversing and reversing version.

The non-reversing version ensures the gate is mechanically locked when the motor is not operating and, therefore, no lock needs to be installed and is equipped with a manual release with key.

The reversing version needs an electric lock to ensure the lock of the leaf.

The "LS" models are equipped with opening and closing limit-switches.

ATTENTION: Correct operation and declared characteristics can be obtained only by using GENIUS accessories and safety devices.

The SKILL automated systems were designed and manufactured to control access of vehicles. Avoid any other use whatever.

1. DESCRIPTION

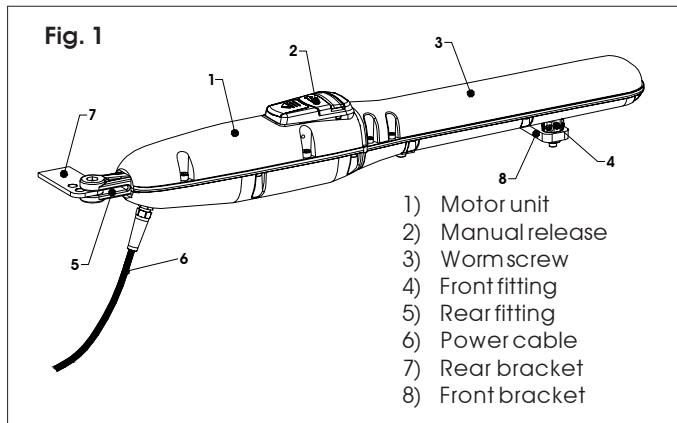

2. DIMENSIONS

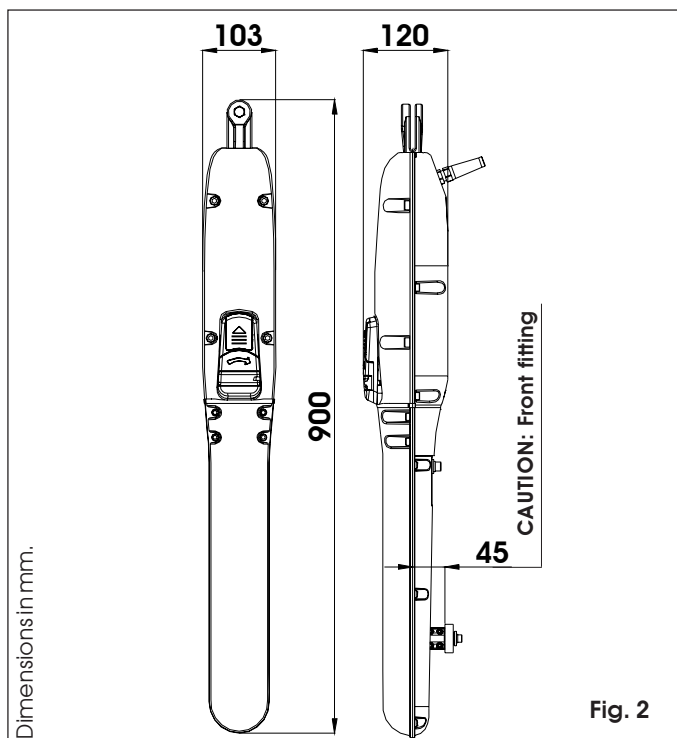

3. VERSIONS AND TECHNICAL SPECIFICATIONS

MODEL	VERSION
SKILL V	rapid non-reversing
SKILL L	slow non-reversing
SKILL VR	rapid reversing
SKILL LR	slow reversing
SKILL V - LS	rapid non-reversing with opening and closing limit-switch
SKILL L - LS	slow non-reversing with opening and closing limit-switch
SKILL VR - LS	rapid reversing with opening and closing limit-switch
SKILL LR - LS	slow reversing with opening and closing limit-switch

MODEL	SKILL	
	V - VR V LS - VR LS	L - LR L LS - LR LS
Power supply	230Vac 50 (60)Hz	
Absorbed power	250W	
Absorbed current	1.05A	
Electric motor	1000 rpm	
Thermal protection	140°C	
Capacitor	6.3 μF	
Thrust	180 daN	200 daN
Travel	305 mm.	
Speed	1.4 cm/sec	1.2 cm/sec
Max. leaf	2 m	3.5 m
Use frequency 20°C	S3 - 30%	
Consecutive cycles 20°C	15	
Operating ambient temperature	-20°C +55°C	
Protection class	IP44	
Operator weight	8.4 kg.	
Operator dimensions	see fig. 2	

4. ELECTRIC EQUIPMENT (standard system)

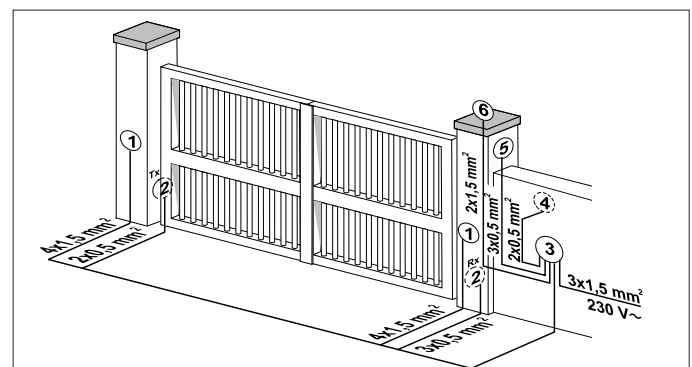

- 1) Operators
- 2) Photocells
- 3) Control board
- 4) Key-operated push-button
- 5) Receiver
- 6) Flashing lamp

Fig. 3

- Notes:**
- 1) To lay electric cables, use adequate rigid and/or flexible tubes.
 - 2) Always separate low voltage accessories cables from power cables at 230V ~. To avoid any interference, always use separate sheaths.

5. INSTALLATION OF THE AUTOMATED SYSTEM

5.1. PRELIMINARY CHECKS

To ensure trouble-free operation of the automated system, make sure that the structure of the existing gate or the gate to be installed, complies with the following requirements:

- max. single leaf length up to 2 metres (with V and VR operator versions);
- max. single leaf length up to 3.5 metres (with L and LR operator versions);
- sturdy and rigid leaf structure;
- proper and uniform movement of the leaves, without any irregular friction during their entire travel;
- good condition of existing hinges;
- presence of mechanical stops.
- presence of the electric lock for the reversing version.
- presence of an efficient earthing for the electric connection of the operator.

We advise you to carry out any metalwork jobs before installing the automated system.

The condition of the structure directly affects the reliability and safety of the automated system.

5.2. INSTALLATION OF THE OPERATORS

- 1) Secure the rear bracket on the pillar according to the instructions of **Dwg. A**. If necessary, change the length of the supplied bracket.

Any securing errors may be remedied thanks to 4 securing holes on the rear bracket.

Attention: observe the indicated dimensions in order not to endanger the operator efficiency.

In case of iron pillar, carefully weld the bracket directly on the pillar (Fig. 4).

In case of masonry pillar, use the optional plate for a securing to wall or to be bolted (Fig. 4).

Then carefully weld the bracket on the plate.

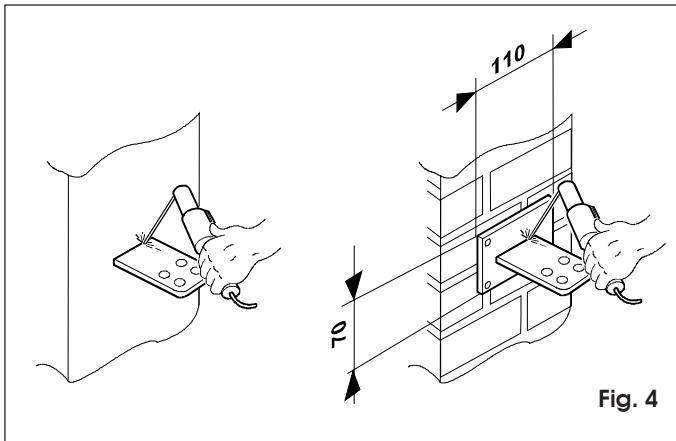

Fig. 4

Dwg. A

INSTALLATION DIMENSIONS

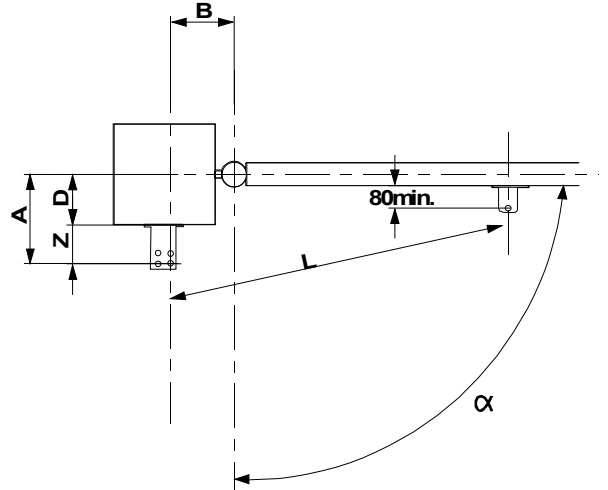

Fig. A

Table A: Recommended dimensions (in mm.)

Model	α	A	B	C ⁽¹⁾	D ⁽²⁾	Z ⁽³⁾	L
Skill	90°	150	150	305	60	75	830
L-V-IR-VR	110°	130	130	305	60	60	830

(1) stem useful travel (2) max. dimension (3) min. dimension

GENERAL RULES TO DETERMINE THE INSTALLATION DIMENSIONS

If the dimensions indicated in table A cannot be realized, the following must be taken into consideration in order to determine different measures:

- to get **90° leaf opening**: $a + b = c$
- to get **leaf opening over 90°**: $a + b < c$
- **lower a and b dimensions determine higher speed.** Current standards have to be complied with.
- **limit the difference of the dimensions a and b within 4 cm:** higher differences cause high speed variations during the opening and closing movement.
- due to the operator overall dimensions, the **min. Z dimension is 80 mm** (Fig. A).
- with the **LS** versions, dimensions **A** and **B** must be used as they enable use of the entire travel. Shorter travel distances could limit or reduce the limit-switch adjustment range to zero.
- If the pillar dimensions or the hinge position make it impossible to keep the dimensions **a** within the desired measure, a niche on the pillar is to be executed as shown in Fig. B.
- **in the LS versions, the limit-switches are tripped only during the first and last 25 mm of travel. As a result, the full travel distance C must be used.**

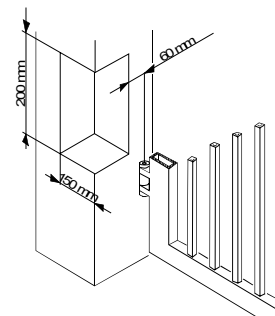

Fig. B

ENGLISH

- 2) Secure the articulated fitting of the operator to the rear bracket by means of the supplied pins (Fig. 5).

Attention: before securing the operator on the rear bracket, which has just been welded, make sure its temperature does not damage the articulated fitting.

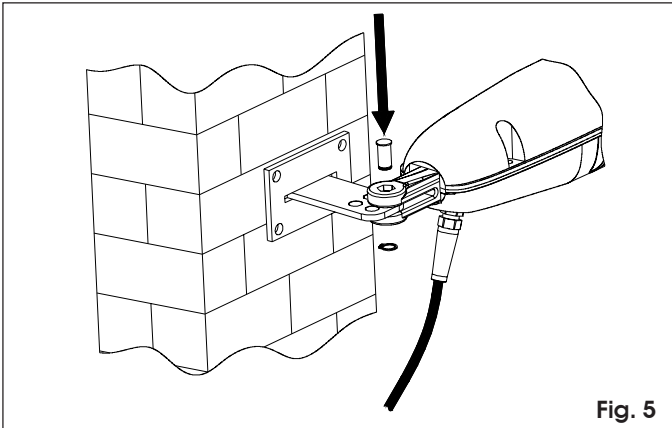

Fig. 5

- 3) Power up the motor and move the front attachment pin backward by about 10 mm (fig. 6).

ATTENTION: The operator can be moved by hand only if installed on the gate in released position.

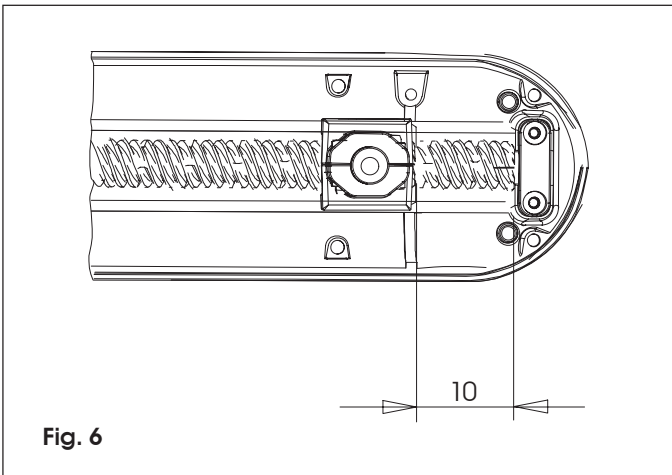

Fig. 6

- 4) Fit the front bracket to the front attachment pin as shown in Fig. 7.

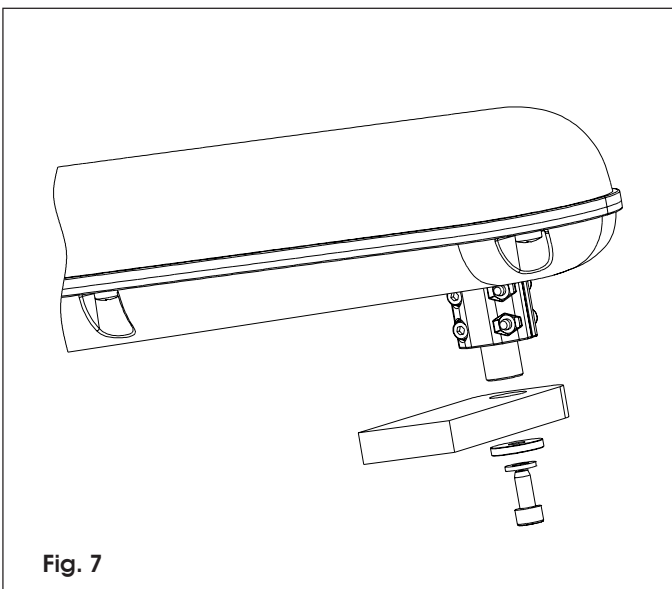

Fig. 7

- 5) Close the gate leaf and, holding the operator in a perfect horizontal position, locate the front bracket securing point on the leaf (Fig. 8).

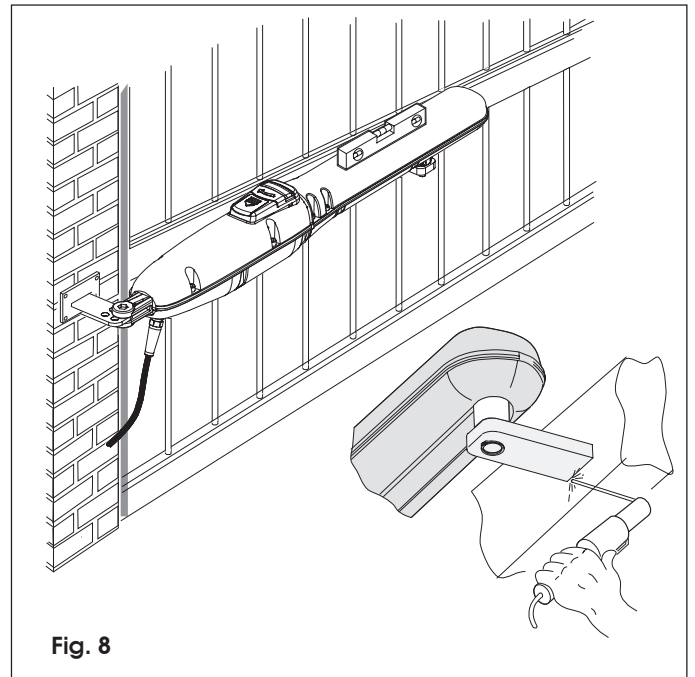

Fig. 8

- 6) Temporarily secure the front bracket on the leaf by means of two welding points.
Note: If the fitting cannot be secured firmly due to the gate structure, a firm resting base on the structure is to be created.
- 7) Release the operator and check manually if the gate is free to open completely up to the mechanical stops and if the leaf movement is regular and without any friction whatever.
- 8) Completely weld the front bracket on the leaf (Fig. 8). To do this, temporarily release the operator from the fitting in order to avoid that welding slag damage it.
Note: We recommend to grease every fixing pin of the fittings.
- 9) Carry out the installation of the second operator, if any, repeating the above mentioned operations.
- 10) Install the enclosure and the control board keeping into consideration the overall dimensions given in the relevant instructions.

6. START-UP

ATTENTION: Before attempting any work on the system or on the operator, always turn off power.

Observe points 10, 11, 12, 13, 14 of the GENERAL SAFETY OBLIGATIONS.

Observing the instructions in Fig.3, lay the raceways and make the electric connections of the control board to the selected accessories.

Always separate power cables from control and safety cables (push-button, receiver, photocells, etc...). To prevent any electric noise whatever, use separate sheaths.

- 1) Program the control board according to your needs observing the concerning instructions.
- 2) Switch on power to the system and check the condition of the LEDs according to the table of the control board instructions.

7. TESTING THE AUTOMATED SYSTEM

Check operating efficiency of the automated system and all accessories connected to it.
Hand the "User's Guide" page to the Client, explain correct operation and use of the operator and indicate the potentially dangerous areas of the automated system.

8. MANUAL OPERATION

If the gate has to be operated manually, **turn off power** and proceed as follows:

- 1) Slide the protective tab, Fig.9 / 1.
- 2) Fit the key and turn it through 90°, Fig.9 / 2.
- 3) Lift up the manoeuvre lever, Fig.9 / 3.
- 4) To release the operator, turn the manoeuvre lever through 180°, as shown by the arrow on the release system Fig.9 / 4.

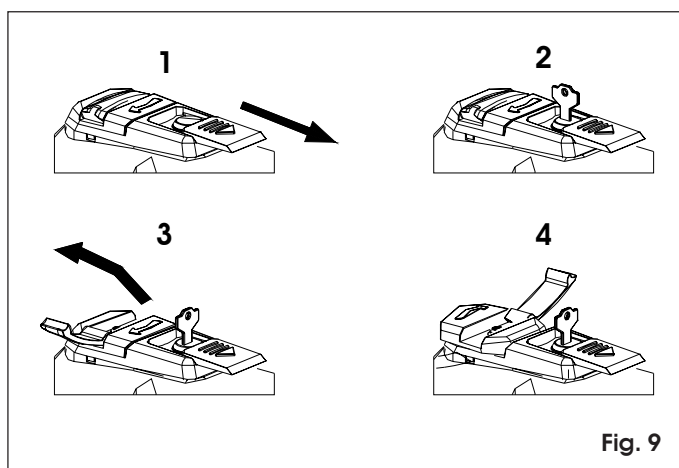

Open or close the leaves manually.
Attention: to keep the operator in manual operation mode, the operator must be **released and without power**.

9. RESTORING NORMAL OPERATION

To restore normal operation mode of the automated system, turn the metal lever clockwise, close the cover and switch on power to the system.
Carry out some manoeuvres in order to check if all functions of the automated system have been correctly restored.

10. MECHANICAL STOP

The SKILL operator is equipped with an opening mechanical stop, Fig.10, which can be adjusted according to need.

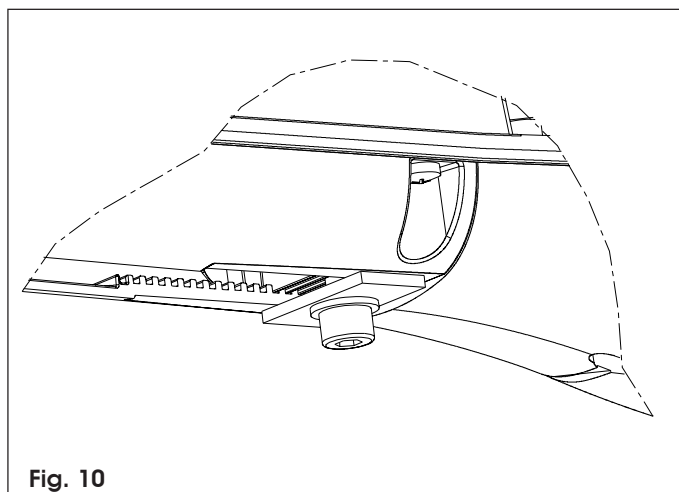

Procedure for adjusting the stop position:

- 1) Release the operator as described in point 8.
- 2) Manually take the leaf into its opening position.
- 3) Loosen the fixing screw, Fig.11 ref. **A**. There is no need to fully remove the screw.

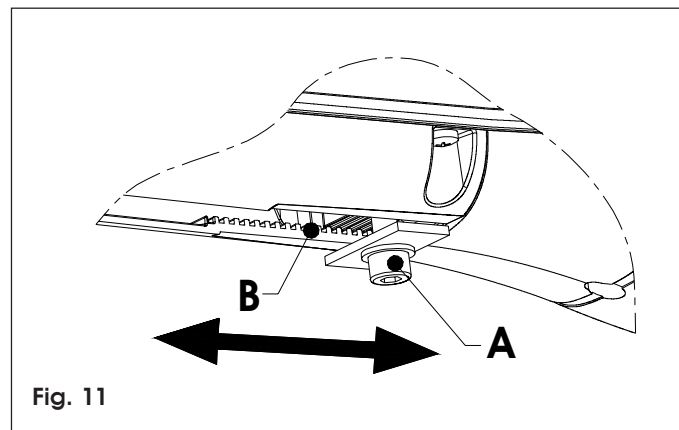

- 4) Shift the stop to the lower support, as shown in fig. 12.
Attention: the mechanical stop operates coupled to a sector gear, Fig. 11 ref. **B**, if anything occurs to impede movement, make sure the coupling is unrestricted. **Do not force**.
- 5) Re-tighten the fixing screw.

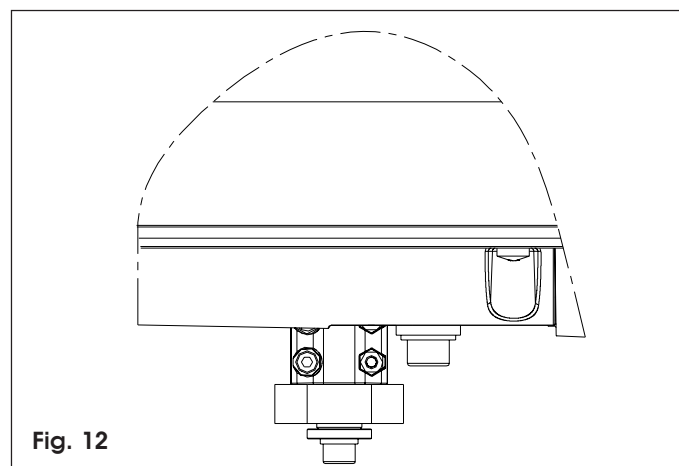

13. ADJUSTING THE LIMIT-SWITCHES

N.B.: The LS versions imply the use of equipment with an input for the limit-switches.

The limit-switches are tripped only during the first and last 25 mm of travel. As result, the full travel distance must be used.

- 1) Remove the mechanical stop and the lower housing, in the order described, as indicated in Fig. 13.

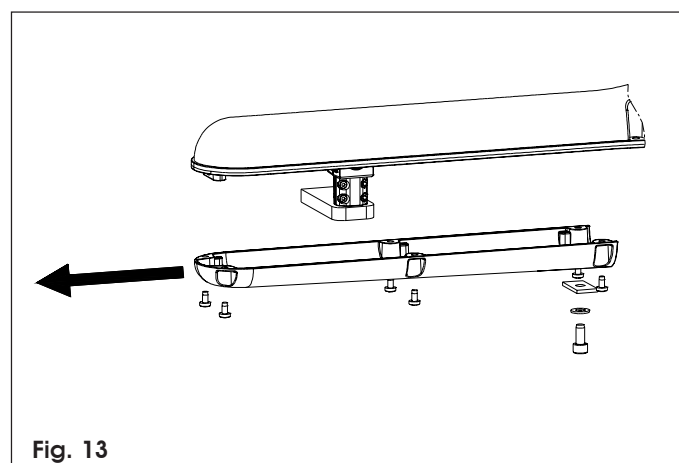

ENGLISH

- 2) Loosen the two screws (Fig.14 ref. **A**), axially shift the closing limit-switch to the required position and re-tighten the two screws.
- 3) Loosen the two screws (Fig.14 ref. **B**), axially shift the opening limit-switch to the required position and re-tighten the two screws.
- 4) Run a couple of test cycles to check if the limit-switches are correctly positioned. If the limit-switches have to be adjusted again, resume from point 2.

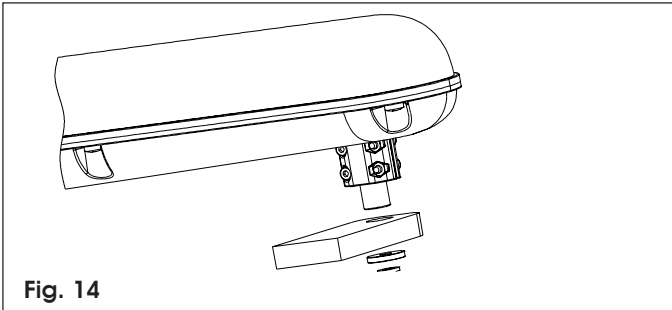

- 5) Re-fit the lower housing.





12.MAINTENANCE

To ensure correct long-term operation, we advise you to carry out the following checks every six months:

- 1) Check if all the safety devices in use are connected and efficient.
- 2) Check if the anti-crushing clutch is correctly set.
- 3) Check the condition and efficiency of the earth connection.
- 4) Check if all screws are tight.
- 5) Check wear and lubrication of the hinges.

13.REPAIRS

For any repairs, contact the authorised Repair Centres.

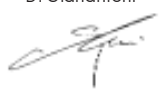
<p>DICHIARAZIONE CE DI CONFORMITÀ PER MACCHINE (DIRETTIVA 89/392 CEE, ALLEGATO II, PARTE B)</p> <p>Fabbricante: GENIUSs.r.l. Indirizzo: Via Padre Elzi, 32 24050 - Grassobbio BERGAMO - ITALIA</p> <p>Dichiara che: L'Attuatore mod. SKILL 01</p> <ul style="list-style-type: none"> è costruito per essere incorporato in una macchina o per essere assemblato con altri macchinari per costituire una macchina ai sensi della Direttiva 89/392 CEE, e successive modifiche 91/368/CEE, 93/44/CEE, 93/68/CEE; è conforme ai requisiti essenziali di sicurezza delle seguenti altre direttive CEE: 73/23 CEE e successiva modifica 93/68/CEE. 89/336 CEE e successiva modifica 92/31 CEE e 93/68/CEE <p>e inoltre dichiara che <u>non è consentito mettere in servizio il macchinario</u> fino a che la macchina in cui sarà incorporata o di cui diverrà componente sia stata identificata e ne sia stata dichiarata la conformità alle condizioni della Direttiva 89/392/CEE e successive modifiche trasposta nella legislazione nazionale dal DPR n° 459 del 24 Luglio 1996.</p> <p>Grassobbio, 1 Marzo 2002</p> <p>L'Amministratore Delegato D. Gianantoni</p> 	<p>EC MACHINE DIRECTIVE COMPLIANCE DECLARATION (DIRECTIVE 89/392 EEC, APPENDIX II, PART B)</p> <p>Manufacturer: GENIUSs.r.l. Address: Via Padre Elzi, 32 24050 - Grassobbio BERGAMO - ITALY</p> <p>Hereby declares that: the SKILL 01</p> <ul style="list-style-type: none"> is intended to be incorporated into machinery, or to be assembled with other machinery to constitute machinery in compliance with the requirements of Directive 89/392 EEC, and subsequent amendments 91/368 EEC, 93/44 EEC and 93/68 EEC; complies with the essential safety requirements in the following EEC Directives: 73/23 EEC and subsequent amendment 93/68 EEC. 89/336 EEC and subsequent amendments 92/31 EEC and 93/68 EEC. <p>and furthermore declares that <u>unit must not be put into service</u> until the machinery into which it is incorporated or of which it is a component has been identified and declared to be in conformity with the provisions of Directive 89/392 EEC and subsequent amendments enacted by the national implementing legislation.</p> <p>Grassobbio, 1 March 2002</p> <p>Managing Director D. Gianantoni</p> 	<p>DÉCLARATION CE DE CONFORMITÉ (DIRECTIVE EUROPÉENNE "MACHINES" 89/392/CEE, ANNEXE II, PARTIE B)</p> <p>Fabrcant: GENIUSs.r.l. Adresse: Via Padre Elzi, 32 24050 - Grassobbio BERGAMO - ITALIE</p> <p>Déclare d'une part que l'automatisme mod. SKILL 01</p> <ul style="list-style-type: none"> est prévue soit pour être incorporée dans une machine, soit pour être assemblée avec d'autres composants ou parties en vue de former une machine selon la directive européenne "machines" 89/392 CEE, modifiée 91/368 CEE, 93/44 CEE, 93/68 CEE. satisfait les exigences essentielles de sécurité des directives CEE suivantes: 73/23 CEE, modifiée 93/68 CEE. 89/336 CEE, modifiée 92/31 CEE et 93/68 CEE. <p>et d'autre part qu'il est formellement interdit de mettre en fonction l'automatisme en question avant que la machine dans laquelle il sera intégrée ou dont il constituera un composant ait été identifiée et déclarée conforme aux exigences essentielles de la directive européenne "machines" 89/392/CEE, et décrets de transposition de la directive.</p> <p>Grassobbio, le 1 Mars 2002</p> <p>L'Administrateur Délégué D. Gianantoni</p> 
<p>DECLARACIÓN DE CONFORMIDAD CE PARA MÁQUINAS (DIRECTIVA 89/392 CEE, ANEXO II, PARTE B)</p> <p>Fabricante: GENIUSs.r.l. Dirección: Via Padre Elzi, 32 24050 - Grassobbio BERGAMO - ITALIA</p> <p>Declara que: El equipo automático mod. SKILL 01</p> <ul style="list-style-type: none"> Ha sido construido para ser incorporado en una máquina, o para ser ensamblado con otros mecanismos a fin de constituir una máquina con arreglo a la Directiva 89/392 CEE y a sus sucesivas modificaciones 91/368 CEE, 93/44 CEE y 93/68 CEE. Cumple los requisitos esenciales de seguridad establecidos por las siguientes directivas CEE: 73/23 CEE y sucesiva modificación 93/68 CEE, 89/336 CEE y sucesivas modificaciones 92/31 CEE y 93/68 CEE. <p>Asimismo, declara que <u>no está permitido poner en marcha</u> el equipo si la máquina en la cual será incorporado, o de la cual se convertirá en un componente, no ha sido identificada o no ha sido declarada su conformidad a lo establecido por la Directiva 89/392 CEE y sus sucesivas modificaciones, y a la ley que la incorpora en la legislación nacional.</p> <p>Grassobbio, 1º de Marzo de 2002.</p> <p>Administrador Delegado D. Gianantoni</p> 	<p>EG-KONFORMITÄTSERKLÄRUNG ZU MASCHINEN (gemäß EG-Richtlinie 89/392/EWG, Anhang II, Teil B)</p> <p>Hersteller: GENIUSs.r.l. Adresse: Via Padre Elzi, 32 24050 - Grassobbio BERGAMO - ITALIEN</p> <p>erklärt hiermit, daß: der Antrieb Mod. SKILL 01</p> <ul style="list-style-type: none"> zum Einbau in eine Maschine oder mit anderen Maschinen zu einer Maschine im Sinne der Richtlinie 89/392 EWG und deren Änderungen 91/368 EWG, 93/44 EWG, 93/68 EWG vorgesehen ist. den wesentlichen Sicherheitsbestimmungen folgender anderer EG-Richtlinien entspricht: 73/23 EWG und nachträgliche Änderung 93/68 EWG 89/336 EWG und nachträgliche Änderung 92/31 EWG sowie 93/68 EWG <p>und erklärt außerdem, daß die <u>Inbetriebnahme solange untersagt ist</u>, bis die Maschine, in welche diese Maschine eingebaut wird oder von der sie ein Bestandteil ist, den Bestimmungen der Richtlinie 89/392 EWG sowie deren nachträglichen Änderungen entspricht.</p> <p>Grassobbio, 1 März 2002</p> <p>Der Geschäftsführer D. Gianantoni</p> 	<p>Le descrizioni e le illustrazioni del presente manuale non sono impegnative. GENIUS si riserva il diritto, lasciando inalterate le caratteristiche essenziali dell'apparecchiatura, di apportare in qualunque momento e senza impegnarsi ad aggiornare la presente pubblicazione, le modifiche che essa ritiene convenienti per miglioramenti tecnici o per qualsiasi altra esigenza di carattere costruttivo o commerciale.</p> <p>The descriptions and illustrations contained in the present manual are not binding. GENIUS reserves the right, whilst leaving the main features of the equipments unaltered, to undertake any modifications to holds necessary for either technical or commercial reasons, at any time and without revising the present publication.</p> <p>Les descriptions et les illustrations du présent manuel sont fournies à titre indicatif. GENIUS se réserve le droit d'apporter à tout moment les modifications qu'elle jugera utiles sur ce produit tout en conservant les caractéristiques essentielles, sans devoir pour autant mettre à jour cette publication.</p> <p>Las descripciones y las ilustraciones de este manual no comportan compromiso alguno. GENIUS se reserva el derecho, dejando inmutadas las características esenciales de los aparatos, de aportar, en cualquier momento y sin comprometerse a poner al día la presente publicación, todas las modificaciones que considere oportunas para el perfeccionamiento técnico o para cualquier otro tipo de exigencia de carácter constructivo o comercial.</p> <p>Die Beschreibungen und Abbildungen in vorliegendem Handbuch sind unverbindlich. GENIUS behält sich das Recht vor, ohne die wesentlichen Eigenschaften dieses Gerätes zu verändern und ohne Verbindlichkeiten in Bezug auf die Neufassung der vorliegenden Anleitungen, technisch bzw. konstruktiv / kommerziell bedingte Verbesserungen vorzunehmen.</p>

GENIUS®

GENIUS s.r.l.
Via Padre Elzi, 32
24050 - Grassobbio
BERGAMO-ITALY
tel. 0039.035.4242511
fax. 0039.035.4242600
info@geniusg.com
www.geniusg.com

Timbro rivenditore: / Distributor's stamp: / Timbre de l'agent: /
Sello del revendedor: / Fachhändlerstempel:

