

DOM-TX15

Radio control, rolling code, 433.92 MHz,
15 channels and 4 groups, Up-Down-Stop and pulse



ISDOM-TX15_ENV_1.0

1- PRODUCT FEATURES

1.1 TECHNICAL DATA

Power supply	Type CR2450 lithium battery
Programmable channels	15
Groups	4
Radio frequency	433,92 MHz ISM
Range	100 meters
Code	Rolling code
Dimensions	Diameter 80 x 13

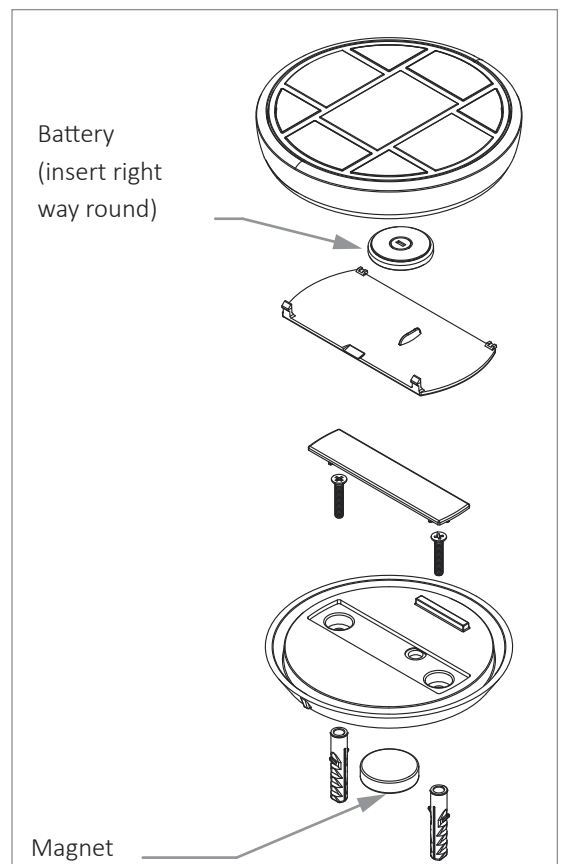
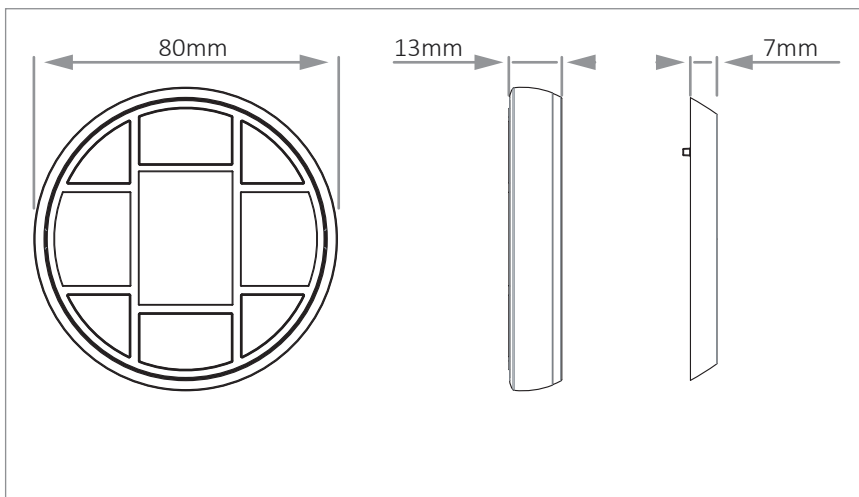

2 - USE OF TRANSMITTER

2.1 DESCRIPTION OF TRANSMITTER

Multichannel radio control to control 30 devices and 4 groups. Up-Down-Stop and pulse controls, display and LEDs for channel and group selection. Aluminium alloy structure and shock-absorbent polycarbonate plastic parts. Magnetic wall support.

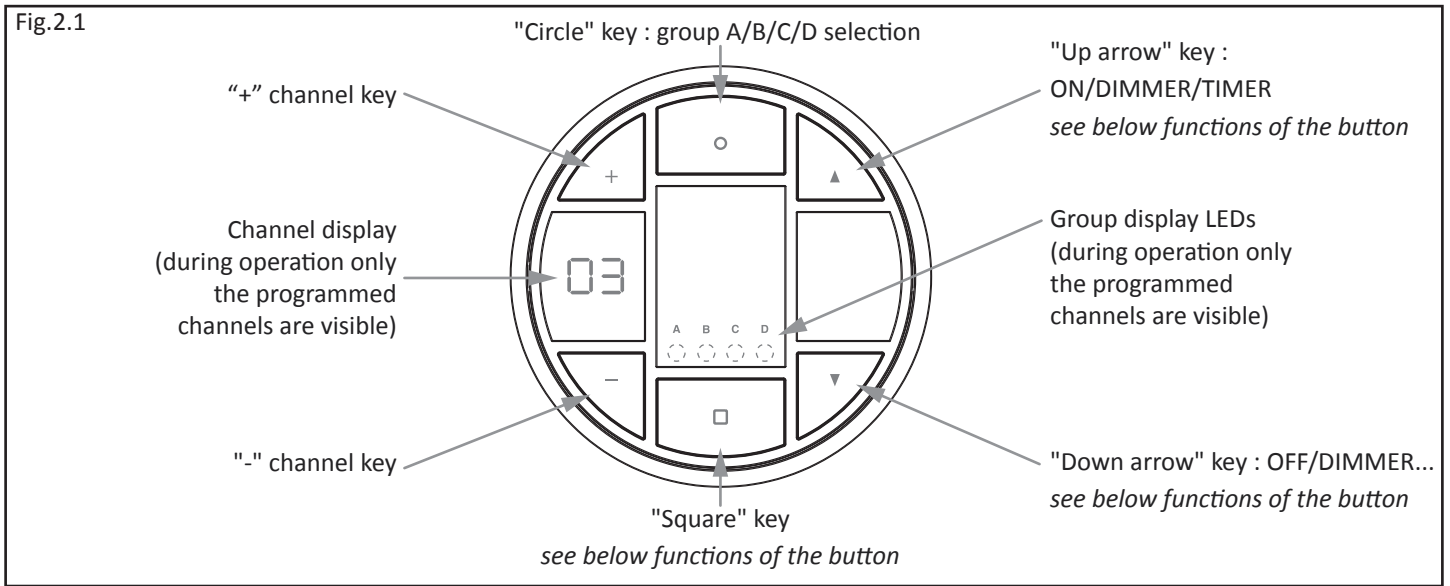

2.2 USE OF TRANSMITTER

To be able to use the transmitter you must first carry out the learning procedures on the receiver (see paragraph 3).

SEND A COMMAND TO A DEVICE:

- 1- With the "+" and "-" keys, select on the display the channel associated with the device that you want to use.
- 2- Send the desired command with the "square", "up arrow" or "down arrow" keys (see paragraph 2.3).
- 3- The transmitter remains in stand-by for 3 seconds and then switches off.

SEND A COMMAND TO A GROUP OF DEVICES:

- 1-With the "circle" key select on the LEDs the group of devices that you want to command (group "A", "B", "C" or "D").
- 2- Send the desired command with the "square", "up arrow" or "down arrow" keys (see paragraph 2.3).
- 3- The transmitter remains in stand-by for 3 seconds and then switches off.

SWITCHING OFF THE TRANSMITTER

The transmitter will automatically switches off after 5 seconds of inactivity; to switch off quickly press the "-" key and the "▼" key simultaneously.

2.3 COMMANDS SENT FROM TRANSMITTER

The following table shows the different commands the transmitter sends depending on the device it is programmed on. The left-hand column shows the transmitter commands, the top row the type of controller

Transmitter key	Monostable device	Timed device	On/off device	Dimmer device	RGBW device	Up/down/stop device	Connector device
□ Short	Pulse	Timer starts	On/Off	On/Off	On/Off	Stop	On/Off
□ Long (>3s)	-	Off	Off	Off	Off	-	-
▲	-	Timer starts	On	LIGHT OFF: On 60% LIGHT ON: Dimmer UP	Dimmer Up	Open	-
▼	-	Off	Off	LIGHT OFF: On 30% LIGHT ON: Dimmer down	Dimmer Down	Close	-

3- TRANSMITTER PROGRAMMING

If you try to select a channel by default the letters "SE" (setting) will appear on the display to indicate that no channel is programmed. To use the transmitter at least one channel must be programmed (paragraph 3.1). During programming it is also possible to decide whether this channel belongs to a group.

EXAMPLE OF GROUP USE: I want to control multiple lights, either separately (for example, to switch on only the light in the "kitchen"), but also in groups (for example, to turn off all the lights on level "group A").

WARNING: It is recommended that the group function is only used with devices of the same type (for example: groups of on/off lights, dimmable lights, or motors). This will result in similar behaviour during group control.

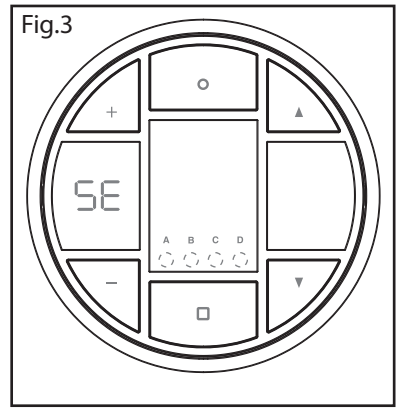

3.1 TRANSMITTER PROGRAMMING

Default: no channel programmed.

This procedure is used to programme a channel in order to then associate it with a compatible receiver. Access to the receiver is required to carry out the following procedure.

PROCEDURE:

- 1- Activate the receiver on which you want to programme the transmitter in "multifunctional remote control radio programming" mode (see receiver manual).
- 2- With the transmitter in stand-by (transmitter off), hold down the "circle" button until the figure "01" flashes on the display.
- 3- With the "+" and "-" keys, select the channel that you want to associate with the receiver (the channels that are already used have the dot lit up on the right on the display, see example in figure 3.1).
- 4- If you want this channel to be part of a group, also select the group it will belong to ("A", "B", "C" or "D"), using the "circle" button.
- 5- Press the "square" button to send a transmission.
- 6- The receiver flashes 3 times to confirm the learning process (see receiver manual).
- 7- The transmitter goes back into stand-by.

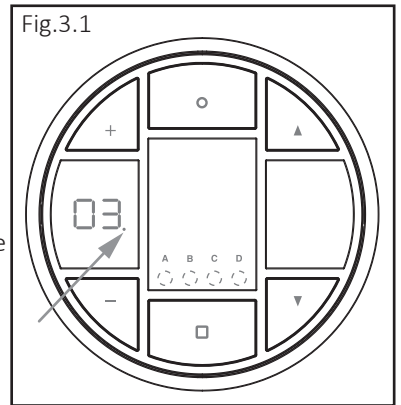

NB : to exit quickly from the programming mode, press simultaneously on "-" and "▼" buttons

3.2 "REMOTE" ACTIVATION OF RECEIVER PROGRAMMING

Once the transmitter has been programmed following the procedure in paragraph 3.1, this transmitter can be used for remote activation of receiver programming and therefore to add further remote controls without accessing the receiver.

PROCEDURE:

- 1- Take up position near to the receiver.
- 2- With the transmitter already programmed, choose the channel associated with the receiver and press the "up arrow" and "down arrow" keys at the same time for 3 seconds (the transmitter will start to flash). The receiver that the transmitter channel has been programmed on is activated for 30 seconds.
- 3- Send a command with the new transmitter that you want to programme (see transmitter manual for use).

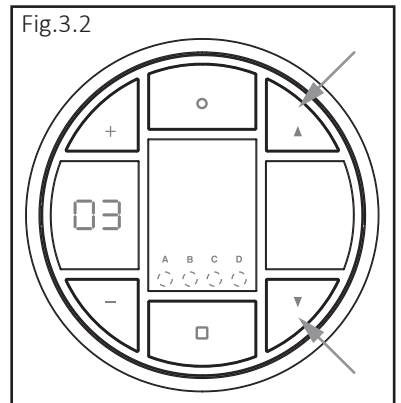

WARNING: Once the signal has been received from the new transmitter, the control unit will go back to normal operation; if you want to programme other transmitters repeat the procedure.

4- DELETION OF A CHANNEL

This procedure can be used to delete a previously created channel. WARNING: before deleting the channel from the transmitter (paragraph 4.2) it is advisable to delete it from the receiver's memory (paragraph 4.1).

4.1 DELETION OF THE CHANNEL FROM THE RECEIVER

This procedure is to delete one of the transmitter's channels from the memory of the receiver on which it was programmed.

PROCEDURE:

1- Access the receiver and carry out the "delete single transmitter" procedure (see receiver manual).

After this procedure the channel will no longer be associated with the receiver and therefore will have no effect; to also delete the visualisation of the channel from the transmitter in standard operation, see the procedure in paragraph 4.2.

4.2 DELETION OF THE CHANNEL FROM THE TRANSMITTER

This procedure is used to delete a channel from the transmitter so that it can no longer be displayed or used.

WARNING: if the channel that you want to delete was associated with a receiver during the creation phase, it is advisable to delete it from the receiver's memory first (see paragraph 4.1).

PROCEDURE:

1- With the transmitter in stand-by (display off), hold down the "circle" button until the figure "01" flashes on the display. .

2- With the "+" and "-" keys, select the channel that you want to delete from the transmitter. The channels that are in se have the dot lit up on the right on the display (see figure 4.2).

3- Hold down the "down arrow" button for 3 seconds. The display flashes and the channel is deleted

4- The transmitter goes back into stand-by.

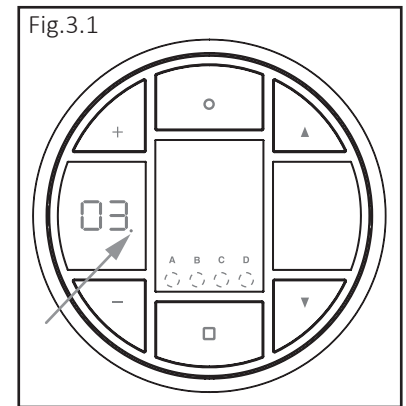

PRASTEL France
ZI Athelia II
225 impasse du Serpolet
13600 La Ciotat - France
Tel : +334 42 98 06 06
prastel.com