

Hyke HS

For hi-speed automation of swing gates with leaves up to 3 m or 270 Kg



Ideal for residential applications even with large columns.

24 Vdc electromechanical gear motor with articulated arm, surface mounted, with magnetic encoder.

Ideal for intensive use and quick manoeuvres: 90° opening in about 10* seconds.

Ultra-powerful and reliable: thanks to the torque of 500 Nm and encoder technology, for millimetric precision and reliability.

Safe movement: dual technology obstacle detection.

Sturdy: thanks to the housing in aluminium with polyester paint finish, resistant to atmospheric agents.

Two irreversible 24 Vdc versions with limit switches on opening and closing: with built-in control unit (HK7024) and without control unit (HK7224).

Practical and quick installation: the articulated arm is adjustable in length for maximum flexibility.

Simple and precise limit switch adjustment: mechanical stops and micrometric adjustment screws.

No black out: with the optional batteries (PS124) housed inside the gear motor.

Built-in control unit (HK7024):

- simple programming, by means of a single key;
- automatic memorization of limit switches on opening and closing with self-learning function;
- automatic fault diagnostics;
- programming of pause time;
- pedestrian pass door;
- deceleration on opening and closing;
- obstacle detection with dual technology;
- provision for connection of latest generation resistive sensitive edges.

* Considering standard installation, excluding acceleration and deceleration.

Nice **BiDirectional products** indicate the status of the automations and confirm correct reception of the command.

Discover the complete range of BiDirectional products on page 176.

Yubii is the new Nice ecosystem that connects all the automations in the home.

Discover all the benefits of the Yubii system on page 170.

COMMON ACCESSORIES



CORE
Nice Wi-Fi-Radio Gateway.

Pc./Pack 1



IT4WIFI
Smart Wi-fi interface to manage gates and garage doors by smart-phone (*).

Pc./Pack 1



HKA2
Spare control unit, for HK7024HS.

Pc./Pack 1



PS124
24 V battery with integrated battery charger.

Pc./Pack 1



PLA10
Vertical 12 V electric lock.

Pc./Pack 1



PLA11
Horizontal 12 V electric lock.

Pc./Pack 1



KIO
Key-operated selector switch for low voltage contacts, with release mechanism for metal cord.

Pc./Pack 1



KA1
6 m cable release kit for KIO.

Pc./Pack 1



TS
Signboard.

Pc./Pack 1



SOLEMYO KIT
The solar power to automate gates, garage doors or barrier gates.

See page 229.

* Not compatible with the Solemyo kit and PS124

TECHNICAL SPECIFICATIONS

Code	Description	Pack/Pallet
HK7024HS	Irreversible 24 Vdc, fast, with magnetic encoder, complete with articulated arm and built-in control unit	12
HK7224HS	Irreversible 24 Vdc, fast, complete with articulated arm without control unit	12

Code	HK7024HS	HK7224HS
ELECTRICAL DATA		
Power supply (Vac 50/60 Hz)	230	-
Power supply (Vdc)	-	24
Absorption (A)	1,5	6
Power (W)	300	140
PERFORMANCE DATA		
Speed (rpm)	>> 2 <<	
Torque (Nm)	500	
Work cycle (cycles/hour)	40	
DIMENSIONAL AND GENERAL DATA		
Protection level (IP)	54	
Working temp. (°C Min/Max)	-20 ÷ +50	
Dimensions (mm)	290x210x320 h	
Weight (kg)	10,5	9,5

UTILISATION LIMITS

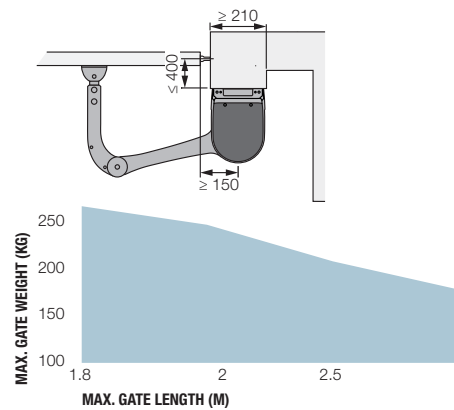

The shape, the height of the gate and the weather conditions can considerably reduce the values shown in the graph to the side.

DIMENSIONS

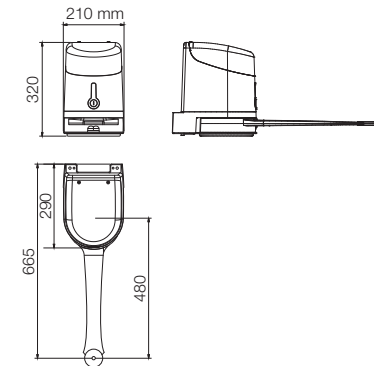

COMPATIBILITY TABLE WITH CONTROL SYSTEMS AND ACCESSORIES

Code	receiver		transmitter							photocells							flashing light							
	Built-in*	OXI	OXI BD	OXLRL	ERA INTI	ERA ONE	ERA ONE BD	ERA ONE LR	ERA FLOR	NICEWAY	EPS	EPM	EPL	EPSB	EPMB	EPLB	EPMDW	F210	FT210	F210B	FT210B	ELAC	ELDC	WLT
HK7024HS		•	•	•	•	•	•	•	•	•				•	•	•	•			•		•		

* Radio receiver incompatible with Opera system

For swing gates
Hi-Speed series

For sliding gates

Barrier gate
operator systems

For garage
and industrial doors

Control systems
and accessories

Compatibility table
and alphabetical index