

# Hyke

For swing gates with leafs of up to 3.5 m, including with large posts

## Ideal for intensive use.

24 Vdc electromechanical gear motor with articulated arm, surface mounted, with magnetic encoder.

**Reliability and durability over time:** thanks to the housing in aluminium with polyester paint finish, resistant to atmospheric agents.

**Safe:** obstacle detection system and monitoring of the motor absorption during movement, self-diagnosis by means of a flashing light, courtesy LED light.

The latest generation optical and resistive 8.2 KOhm sensitive edges can also be connected.

**Two irreversible 24 Vdc versions** with limit switches on opening and closing: with built-in control unit (HK7024) and without control unit (HK7224).

**Practical and quick installation:** the articulated arm is adjustable in length for maximum flexibility.

**Simple and precise limit switch adjustment:** mechanical stops and micrometric adjustment screws.

**Easy to operate release lever:** with metal lock and personalised Nice key. With provision for cable control.

**Savings, respect for the environment, and autonomy:** when connected to the buffer battery or Solemyo kit, consumption on standby is just 0.1 W.

**No black out:** with the optional batteries (PS124) housed inside the gear motor.

### Built-in control unit (HK7024):

- simple programming, by means of a single key;
- automatic memorization of limit switches on opening and closing with self-learning function;
- automatic fault diagnostics;
- programming of pause time;
- pedestrian pass door;
- deceleration on opening and closing;
- obstacle detection with dual technology;
- provision for connection of latest generation resistive sensitive edges.

Nice **BiDirectional products** indicate the status of the automations and confirm correct reception of the command.

Discover the complete range of BiDirectional products on page 176.

**Yubii** is the new Nice ecosystem that connects all the automations in the home.

Discover all the benefits of the Yubii system on page 170.



## COMMON ACCESSORIES



**CORE**  
Nice Wi-Fi-Radio Gateway.  
Pc./Pack 1



**IBT4N**  
Interface for connecting the O-View programming unit.  
Pc./Pack 1



**IT4WIFI**  
Smart Wi-fi interface to manage gates and garage doors by smartphone (\*).  
Pc./Pack 1



**HKA2**  
Spare control unit, for HK7024.  
Pc./Pack 1



**PS124**  
24 V battery with integrated battery charger.  
Pc./Pack 1



**PLA10**  
Vertical 12 V electric lock (required for gates longer than 3 m).  
Pc./Pack 1



**PLA11**  
Horizontal 12 V electric lock (required for gates longer than 3 m).  
Pc./Pack 1



**KIO**  
Key-operated selector switch for low voltage contacts, with release mechanism for metal cord.  
Pc./Pack 1



**KA1**  
6 m cable release kit for KIO.  
Pc./Pack 1



**TS**  
Signboard.  
Pc./Pack 1



**SOLEMYO KIT**  
The solar power to automate gates, garage doors or barrier gates.  
See page 229.

\* Not compatible with the Solemyo kit and PS124

## TECHNICAL SPECIFICATIONS

Code	Description	Pack/Pallet
<b>HK7024</b>	Irreversible 24 Vdc, complete with articulated arm and built-in control unit	12
<b>HK7224</b>	Irreversible 24 Vdc, complete with articulated arm without control unit	12

Code	HK7024	HK7224
<b>ELECTRICAL DATA</b>		
Power supply (Vac 50/60 Hz)	230	-
Power supply (Vdc)	-	24
Absorption (A)	1,5	6
Power (W)	300	140
<b>PERFORMANCE DATA</b>		
Speed (rpm)		1,5
Torque (Nm)		500
Work cycle (cycles/hour)		40
<b>DIMENSIONAL AND GENERAL DATA</b>		
Protection level (IP)		54
Working temp. (°C Min/Max)		-20 ÷ +50
Dimensions (mm)		290x210x320 h
Weight (kg)	10,5	9,5

## UTILISATION LIMITS

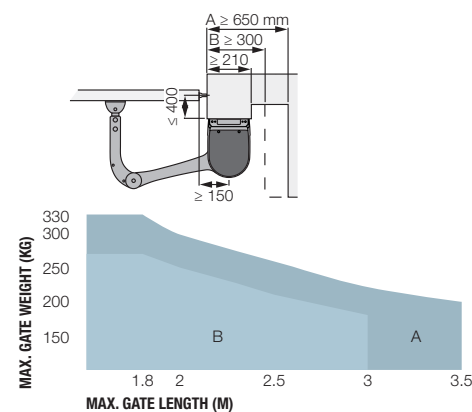

**A** Entire arm - **B** Reduced arm

The shape, the height of the gate and the weather conditions can considerably reduce the values shown in the graph to the side.

## DIMENSIONS

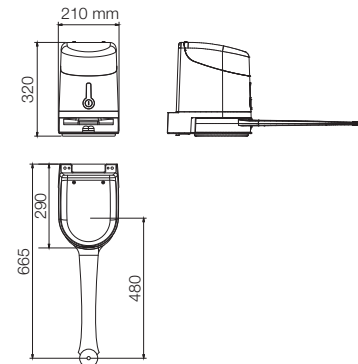

## COMPATIBILITY TABLE WITH CONTROL SYSTEMS AND ACCESSORIES

Code	receiver		transmitter							photocells							flashing light							
	Built-in*	OXI	OXIBD	OXLRL	ERA INTI	ERA ONE	ERA ONE BD	ERA ONE LR	ERA FLOR	NICEWAY	EPS	EPM	EPL	EPSB	EPMB	EPLB	EPMDW	F210	FT210	F210B	FT210B	ELAC	ELDC	WLT
<b>HK7024</b>		•	•	•	•	•	•	•	•					•	•	•	•			•		•	•	•

\* Radio receiver incompatible with Opera system

For swing gates

For sliding gates

Barrier gate operator systems

For garage and industrial doors

Control systems and accessories

Compatibility table and alphabetical index