

INSTALLING AND CONNECTING THE INTRATONE INTRACALL INTERCOM



GENERAL POINTS

The INTRACALL (14-0144) audio intercom is ideal for professional and private use. It connects to an Intratone Telecom module for optimised installation and management.

This guide describes the connection and set-up procedure for the INTRATONE® INTRACALL® intercom.

The Intratone INTRACALL intercom



Operating warranty:

The intercom is guaranteed within a temperature range of -20°C to +70°C and a level of relative humidity not exceeding 70%.

End-of-life recycling of the product:



The intercom and its accessories must not be disposed of with unsorted municipal waste, but must follow the WEEE (Waste Electrical and Electronic Equipment) collection and recycling channel).

TABLE OF CONTENTS

GENERAL POINTS	1
TABLE OF CONTENTS	2
DIMENSIONS	3
A) DIMENSIONS OF THE BUILT-IN WALL BOX AND SURFACE-MOUNTED BOX	3
B) INTERCOM DIMENSIONS	4
WIRING	5
A) WIRING WITH A 3G UNIT AND A RELAY BOARD (12-0110)	5
B) WIRING WITH A TWO-DOOR CENTRAL UNIT (03-0101)	6
EQUIPMENT CONFIGURATION	7
A) EQUIPMENT PROGRAMMING	7
B) INTERCOM SETTINGS	8
POST-INSTALLATION CHECK	8
TROUBLESHOOTING	8
CERTIFICATE OF CONFORMITY	9

DIMENSIONS

A) DIMENSIONS OF THE BUILT-IN WALL BOX AND SURFACE-MOUNTED BOX

**Built-in wall
box
(included)**

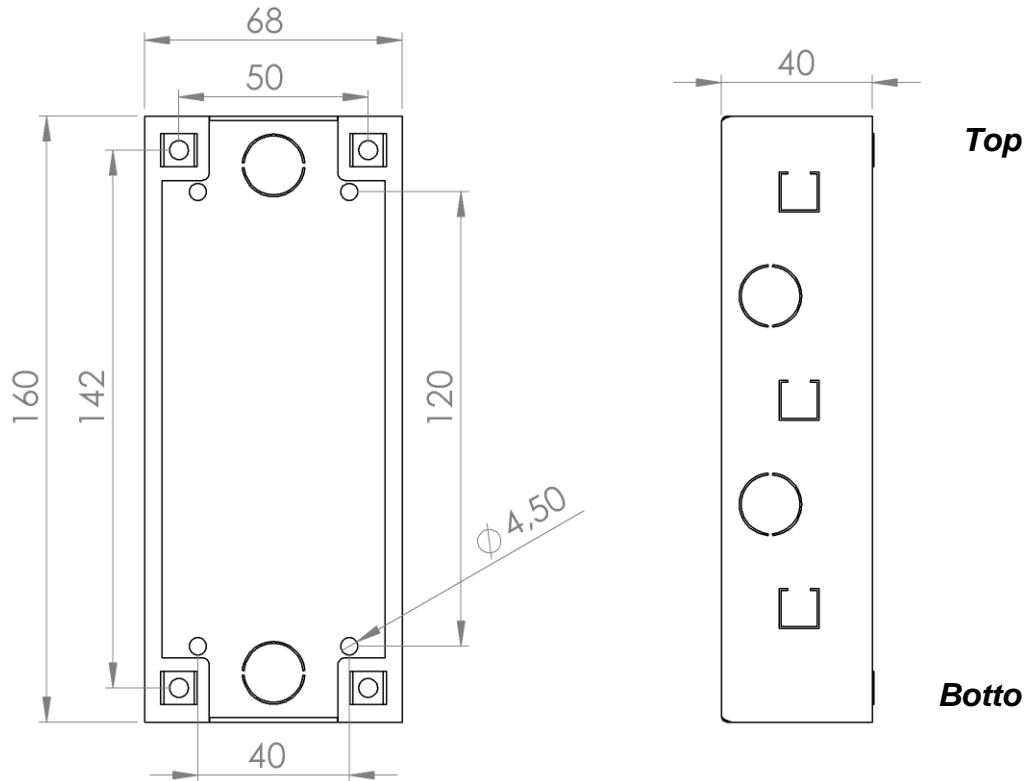

**Surface-
mounted box
(optional)**

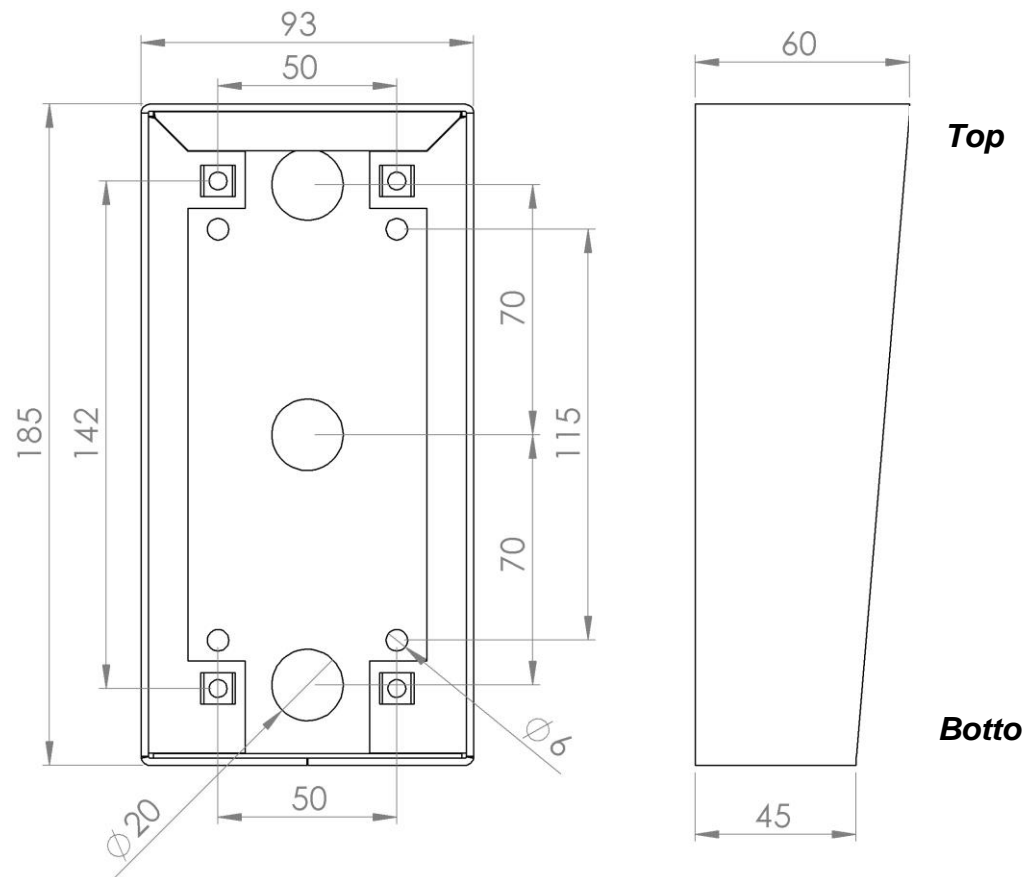

B) INTERCOM DIMENSIONS

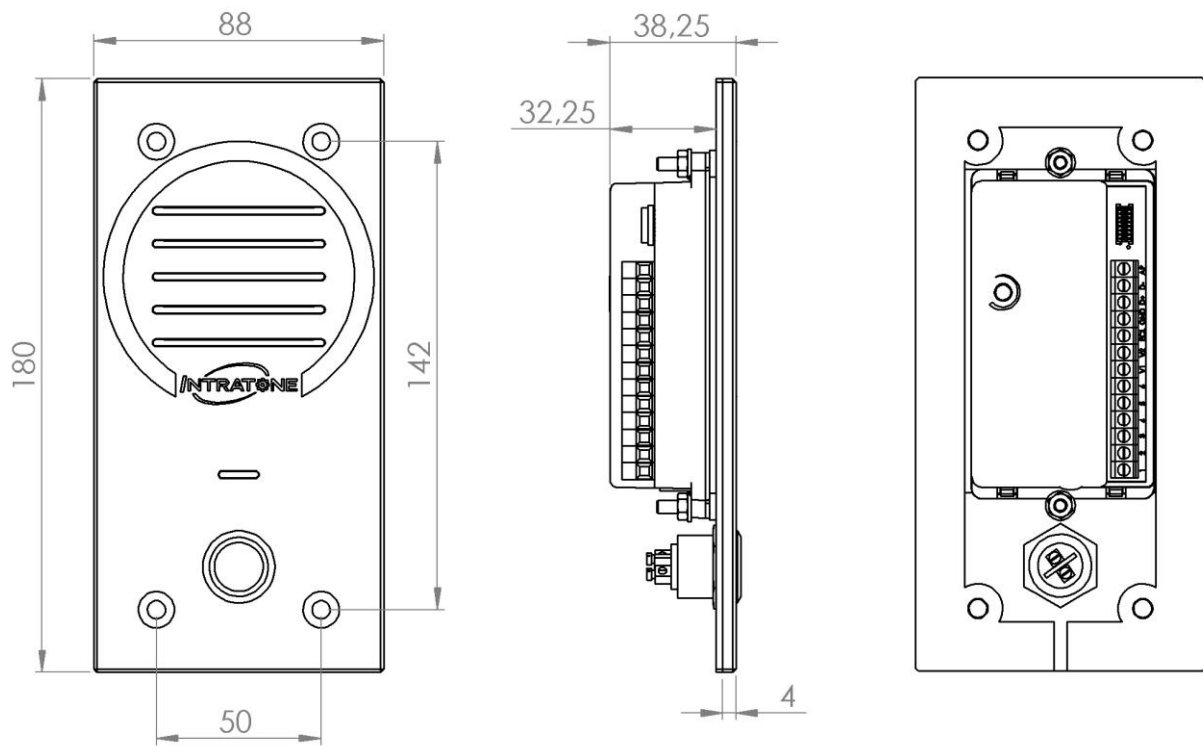

WIRING

A) WIRING WITH A 3G UNIT AND A CIC12 CENTRAL UNIT (03-0102)

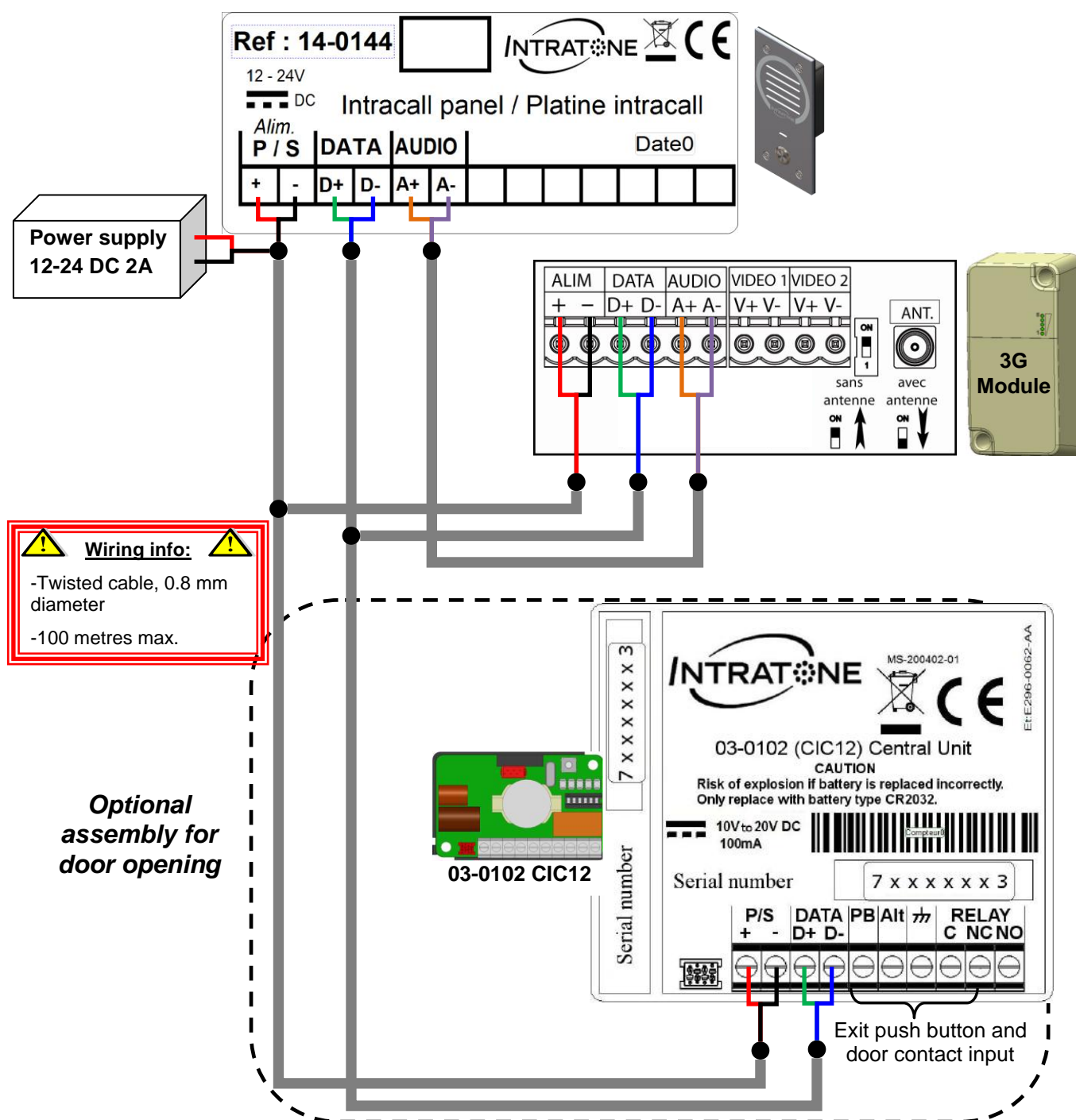

Up to three 12-0110 relay cards maximum can be added to this central unit to allow four doors to be opened together or separately.

B) WIRING WITH A TWO-DOOR CENTRAL UNIT (03-0101)

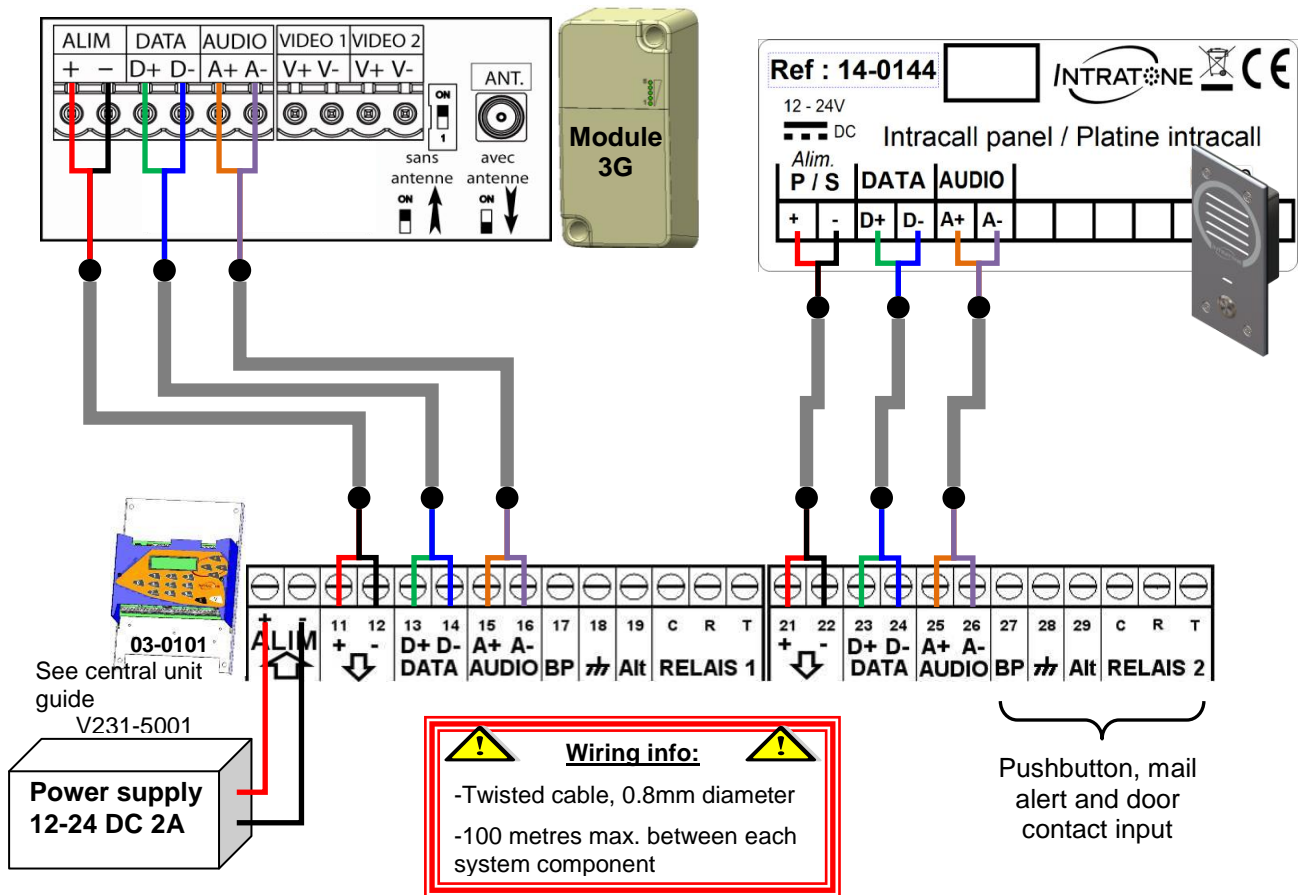

Intercom wiring to connectors 3 and 4 is the same when an extension board is used (12-0109).

EQUIPMENT CONFIGURATION

A) EQUIPMENT PROGRAMMING

The call number programming procedure for this intercom is configured online on www.intratone.com

After logging into your account and creating your apartment building, just declare your Intracall intercom using the “**Create**” button and follow the instructions on screen.



After naming it, and depending on your configuration, you will be asked for the serial number of the central unit and the GSM unit contract reference.

CENTRAL UNIT: hardware match

Configurer

To configure the call numbers, click on your access point to the apartment block and then click on the “**Configure**” button.

Define caretaker call(s)

Configurer

You can then define up to 8 different numbers for each 24-hour period using the time slots configurable online.

Call programming example:

Heure	Du Lundi au Vendredi	Samedi	Dimanche et Fériés
Copier vers	7 zone(s) d'appel		7 zone(s) d'appel
Nb de zone d'appel	7 zone(s) d'appel		7 zone(s) d'appel
00h			
01h			
02h	plage 1 (123456789)	(123456789)	(123456789)
03h			
04h			
05h	plage 2 (123456789)	(123456789)	(123456789)
06h			
07h			
08h	plage 3 (123456789)	(123456789)	(123456789)
09h			
10h			
11h	plage 4 (123456789)	(123456789)	(123456789)
12h			
13h			
14h	plage 5 (123456789)	(123456789)	(123456789)
15h			
16h			
17h	plage 6 (123456789)	(123456789)	(123456789)
18h			
19h			
20h			
21h	plage 7 (123456789)	(123456789)	(123456789)
22h			
23h			

NB: For 3G audio subscriptions, the number of programmed numbers must not exceed the number of records stated in your subscription.

B) INTERCOM SETTINGS

Use the “**Configure me**” item in the “**Central units**” menu to adjust different settings. For instance: volume, number of ring tones, etc.

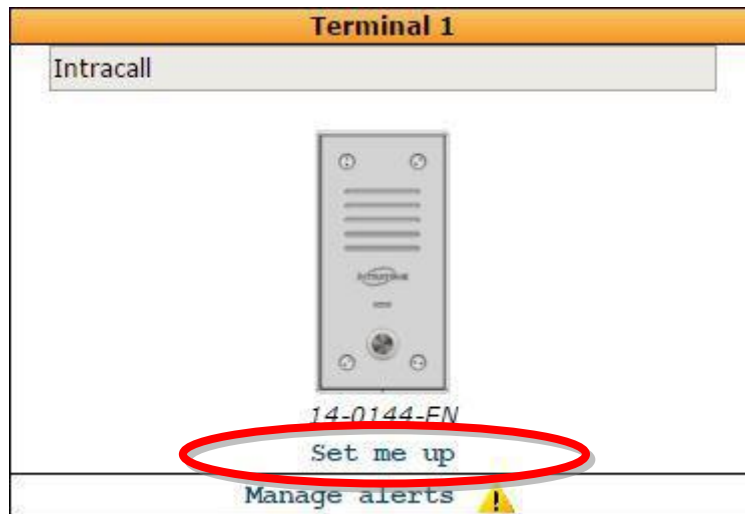

POST-INSTALLATION CHECK

- Checking audio call quality during a call.
- Check that the resident is able to open the door by pressing the * key on the telephone (default) while calling.

TROUBLESHOOTING

Failure	Reason	Resolution
Audio interference	Poor 3G unit reception	Move unit, install an antenna
Call button ineffective	No call number recorded	Check programming
No back-lighting on name holders		Check power supply at intercom terminals
Resident can hardly hear visitors during calls	Microphone obstructed	Clean the microphone port
The intercom calls the telephone correctly but no sound or voice synthesis heard	Incorrect wiring on the A+ and/or A- terminal blocks	Check audio bus wiring

☎ Contact our technical services (+33 (0)2 51 65 51 84) ⓘ

CERTIFICATE OF CONFORMITY



Téléphone : 33 (0)2 51 65 05 79
Télécopie : 33 (0)2 51 63 05 96
E-mail : info@cogetec.fr

DECLARATION DE CONFORMITE D'UN EQUIPEMENT RADIO-ELECTRIQUE (DIRECTIVE R&TTE 1999/5/CE)

FABRICANT

Nom : **COGELEC SAS**
Adresse : **1 rue de l'industrie**
85290 Mortagne sur Sèvre
FRANCE

Téléphone : 33 (0)2 51 65 05 79 Télécopie : 33 (0)2 51 63 05 96 E-mail : info@cogetec.fr

IDENTIFICATION DE L'EQUIPEMENT

Marque :



Désignation commerciale : **Platine Audio Appel Gardien 1 à 3 boutons.**

Références commerciales : **14-0101 : Platine 1 bouton.**
14-0102 : Platine 1 bouton avec lecteur de proximité VIGIK.
14-0103 : Platine 2 boutons.
14-0104 : Platine 3 boutons.

Type : **Platine audio connectable sur nos produits GSM/UMTS et
RTC – version pose en encastrement.**

Application prévue : **Contrôle d'accès pour l'habitation collective.**

Je soussigné, Roger LECLERC président de la société COGELEC SAS :
Déclare sous son entière responsabilité que le produit décrit ci-dessus est en conformité avec les
exigences essentielles applicables de la directive 1999/5/CE :

- Article 3.1a (protection de la santé et sécurité des utilisateurs) :

Norme de sécurité électrique appliquée : EN 60950-1 : 2006

Norme EMF appliquées

EN 62311 : 2008 et EN 50371 : 2002

- Article 3.1b (exigences de protection en ce qui concerne la compatibilité électromagnétique) :

Norme CEM appliquée :

EN 301 489-7 V1.3.1

- Article 3.2 (utilisation efficace du spectre radioélectrique afin d'éviter les interférences dommageables) :

Normes radio appliquée :

EN 301 511 V12.0.0 et EN 302 291-2 V1.1.1

A cet effet, déclare que toutes les séries d'essais radio ont été effectuées.

Date : **20 juillet 2015**

Signature :

1, rue de l'industrie
85290 Mortagne sur Sèvre
FRANCE

SAS au capital de : 437 490€ Code N.A.F. : 322A N° de sirt : 433 034 782 000 22

