

## Ins-30050 : OEM hands free interface, Wiegand 26 bit output

### Suitability

Compatible with hands free readers ✓

Security-sensitive doors ✓

### What is hands free?

The hands free system increases the effective read range of a standard Paxton P or KP series reader.

The system comprises of a hands free interface, a compatible reader (see specification table) and hands free tokens (keycard or keyfob). The system operates by using the field being transmitted by the P series reader to wake up the token which then communicates with the interface which contains a long range receiver.

Existing P and KP readers can be used without modification. The hands free interface takes its power from the control unit and therefore does not require a power supply.

Hands free tokens also include a standard EM4100 proximity ID chip and can therefore be presented to any compatible proximity reader whether they are using the hands free interface or not.

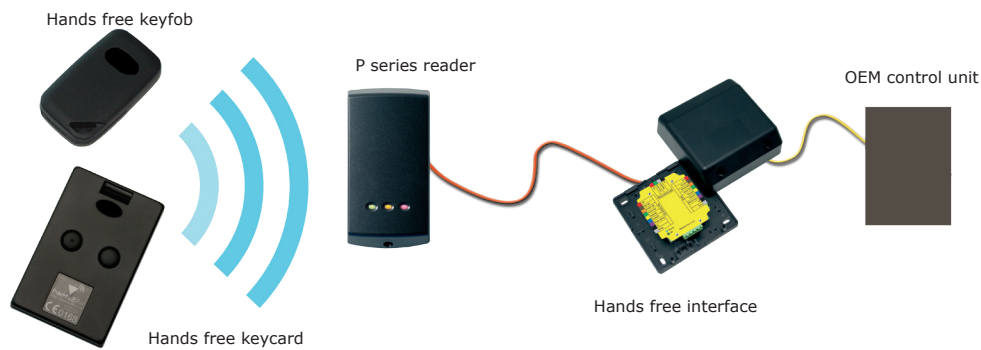

### Before you install

#### Positioning readers

Readers should not be positioned so that their active fields overlap. (see table on back page for typical hands free read ranges)

For example, the minimum distance between a P200 and a P50 reader should be 3.6 m (P200 hands free range = 2.5 m + P50 hands free range = 1.1 m)

For maximum read range the hands free reader field should not be overlapped by the field from other interference sources at or around 125 kHz. These include Loop readers, OEM readers, etc.

For optimum keyfob battery life please choose your reader location carefully to avoid placing it within hands free range of work stations, rest or smoking areas.

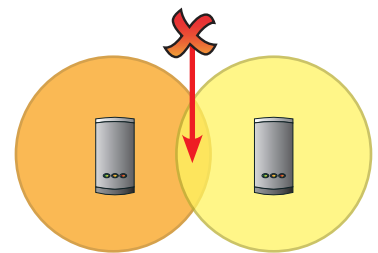

#### Read in, read out

When using in and out readers, users may be picked up by both readers as they move through the door which will reduce the reliability of any roll call or anti-passback application. Ensure that sufficient spacing is provided between these readers for optimum range and reliability.

#### Positioning the interface

The interface should be positioned as close as practical to the reader. A distance from interface to reader of 10 to 15 meters can be achieved but wireless technology is susceptible to environmental factors and so if problems are experienced it may be necessary to move the interface closer to the reader.

The hands free interface should not be housed in a metal enclosure as it contains the main receiver aerial. Sticky feet allow the interface to be stuck to the ACU wiring label in a PSU plastic housing.

## Cable extensions

Readers can be extended using Belden CR9540 10-core overall screened cable to a maximum of 100 metres.

## Wiring

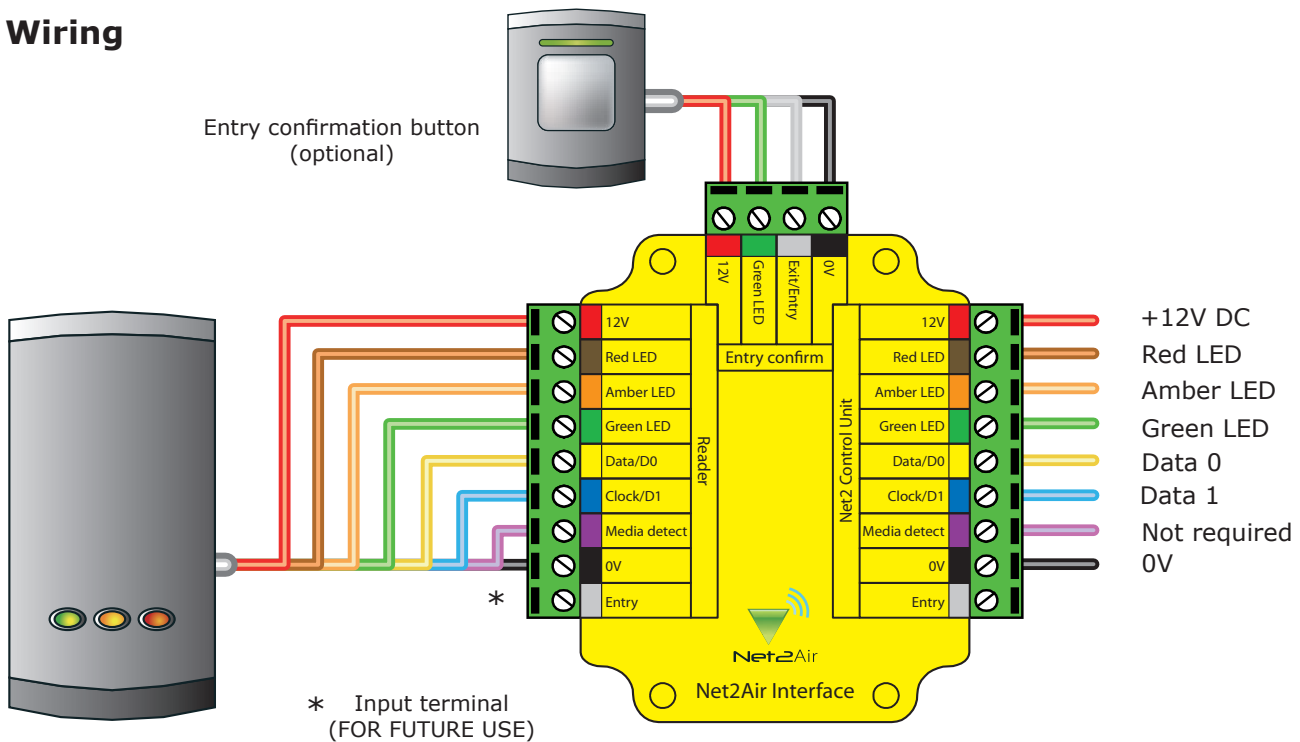

## Configuration

### Firmware download

Hands free firmware for the P series reader will be downloaded from the interface to the reader as soon as it is powered up. This is indicated by flashing amber and red LED's on the reader. Once complete all LED's will be lit.

This may take up to 10 minutes to complete. Do NOT disconnect power during the firmware update.

If the firmware update is still taking place after 10 minutes then remove and then re-connect the ACU cable. Listen to the reader, the reader should NOT beep. If the reader beeps within approximately 10 seconds of power up it will not take the firmware update. Repeat the process until the reader does NOT 'beep' on power up. Then leave for 10 mins to allow the update to take place.

### Using an entry confirmation button

Where two door readers may pick up the same hands free token, a push to make button can be used to confirm an entry request for the specific door. Where fitted, the button LED will flash for 5 seconds after the hands free token has been recognised and must be pressed to unlock the door.

To enable the use of an entry confirmation button do the following steps:

1. Power down the interface board
2. Power up the interface board
3. Press and hold the entry confirmation button for a minimum of 3 seconds within 60 seconds of power up.

To disable the use of the button, repeat the above process.

## Changing frequency channel

If you are experiencing problems with the range or reliability this may be due to poor reader positioning, adjacent interfering 125 kHz or 2.4 GHz equipment, e.g. an adjacent wireless PC network. Please refer to the 'Before you install' information regarding unit locations. If you are still unable to improve the system performance then you may try an alternative 2.4 GHz channel using Switch 1. Power cycle the unit after any changes.

The system has 16 channels available. (Unless a keycard fixed channel is selected) The unit is set to channel 4 as this frequency is normally clear of other device transmissions. This can be changed using a small flat blade screwdriver. Take care not to contact the circuit board with the screwdriver blade as this may damage components.

SW2 - Keycard button 1 and 2 fixed channels - If either switch 1 (Channel 26) or switch 2 (Channel 11) is set, the rotary frequency switch is disabled. If both switches are selected, the interface will not operate.

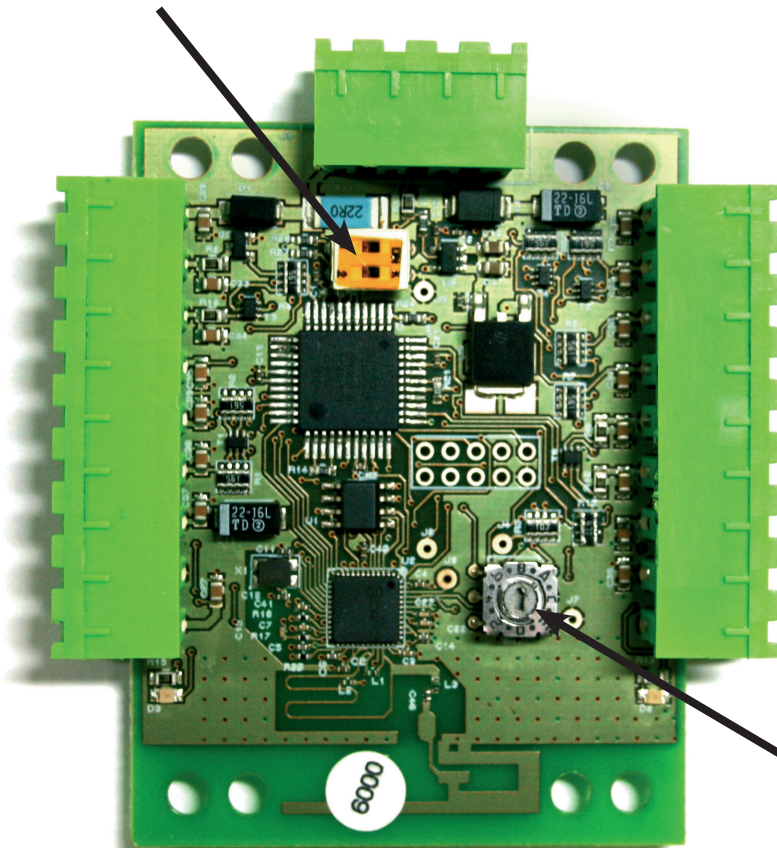

**Interface PCB**

Switch position	GHz	IEEE 802.15.4 channel
0	2.405	11
1	2.41	12
2	2.415	13
3	2.42	14
4	2.425	15
5	2.43	16
6	2.435	17
7	2.44	18
8	2.445	19
9	2.45	20
A	2.455	21
B	2.46	22
C	2.465	23
D	2.47	24
E	2.475	25
F	2.48	26

SW1. Rotate the switch to select an alternate channel.

The switch will initially be set to default position '4'

The hands free tokens will automatically configure themselves to use the new channel.

### Configuring the interface to work with keycards

To enable the buttons, the keycard must first be presented to the P series reader and then used in hands free mode. The keycard stores the details of this interface and can then activate the door using a button.

It can also be used in normal hands free mode and also in local passive mode with other standard readers.

Switch SW2 is used to select the fixed channels used by the two keycard buttons. Select either switch 1 or 2 to set which keycard button the interface will respond to.

The unit must be power cycled if the switch position is changed, to activate the new setting.

# Specifications

	Min	Max	
<b>Dimensions</b>			
Width			71 mm
Height			70 mm
Depth			23 mm
<b>Electrical</b>			
Voltage	11V DC	14V DC	
Current		80 mA	
Carrier frequency			2.4 GHz
Wiegand format			26 bits
Additional power supply required			No
<b>System Specification</b>			
Readers per interface		1	
Button confirmation input			Yes
Cable type for extensions			Beldon 9540
Cable length between ACU and reader		100 m	
Distance between interface and reader		15 m	
<b>Read range with hands free token</b>			
P38		850 mm	
P50		1100 mm	
P75		1500 mm	
P200		2500 mm	
P200E metal mount		2000 mm	
<b>Environment</b>			
Operating temperatures - all items	-20 °C	55 °C	
Waterproof	NO - If used externally, it must be protected in a plastic weatherproof housing		