

Technical Support

01273 811011

support@paxton.co.uk

Technical help is available: Monday - Friday from 07:00 - 19:00 (GMT)
Saturday from 09:00 - 13:00 (GMT)

Documentation on all Paxton products can be found on our website - <http://www.paxton.co.uk/>

Fitting

Ensure that the backbox is mounted vertically and is square with the wall surface.

Care must be taken when doing this, as no further 'twist' adjustment is possible within the reader mountings.

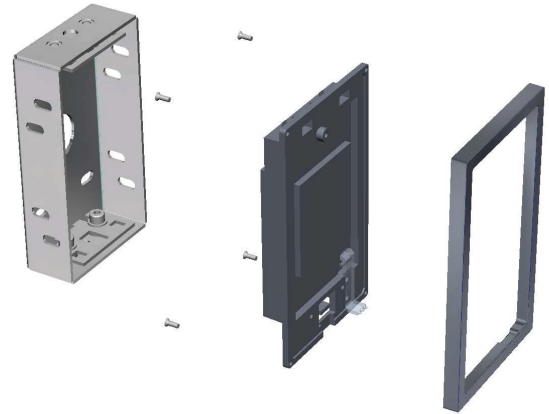

Reader insert

The reader insert is held against the backplate by an outer decorative bezel secured with 4 small screws. Remove these screws to release the bezel and refit after adding the insert.

If you have made an insert of less than 5 mm thick, this can still be fitted by using the 3 nylon screws supplied in the fitting kit to hold the insert against the bezel. (see diagram)

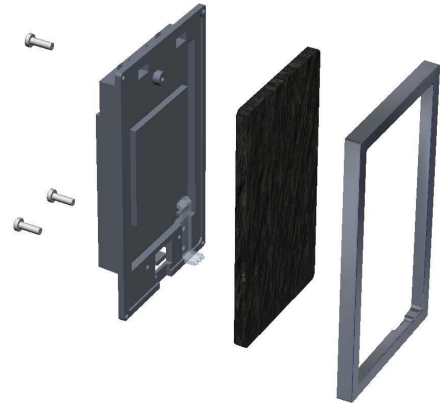

Mounting the reader

Line up the two locating pins on the top of the reader with the top plate inside the backbox. Once located, the reader can be clipped into the box at the bottom using the clip feature.

Check that the reader is located against the surface of the wall. If there is a gap between the reader and the wall, or if the reader will not successfully clip into the box, remove the reader and adjust the mounting plates inside the backbox using a 3 mm Allen key.

Removing the reader

To remove the reader, insert the tool provided into the cut out on the underside of the reader. Push up the clip and pull the reader from the backbox.



Wiring

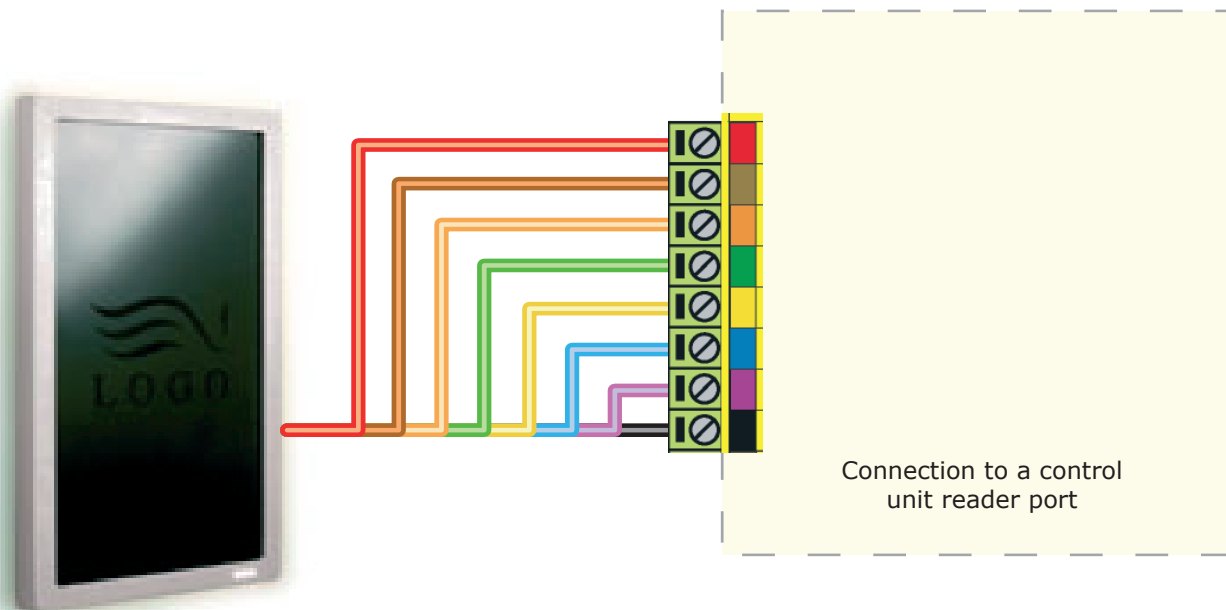

WHITE labelled control units provide 5V at the Red terminal. The Red power wire for the reader should therefore be directly connected to the 12V supply terminal.

IMPORTANT: This reader cannot be connected in parallel with other readers and keypads.

Connection modules

Reader junction box (325-020)

This module can be used to provide a connection point for the reader RJ45 plug. The terminals on the module are then wired colour for colour to the controller.

Alternatively, the reader can be wired directly into the screw terminals of the control unit by first cutting off the RJ45 plug and stripping back the wires in the cable.



Reader port module (325-030)

This module may be purchased separately to speed up the installation and replacement of readers.

The reader port module is designed to convert the standard reader ports on Switch2 and Net2 controllers to accept one or two RJ45 connections. Pull off the screw terminal block from the reader port and simply replace it with this module.

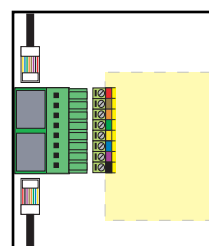

Cable extensions

Readers can be extended using Belden CR9540 10-core overall screened cable to a maximum of 100 metres.

Technical Help

Here is the list of topics about this product that receive the most technical support enquiries. We list them here to help you speed up the installation and trouble shooting process.

1 - Readers/Keypads not working.

- Software settings - Confirm that the settings of the reader or keypad are correct.
- Connections - Check the wiring and integrity of the connectors. If possible, test this reader on the other port.
- Cable - Belden 9540 should be used to extend the reader cable (100 m maximum). Twisted pair alarm cable should not be used. To confirm that an extended reader cable is not faulty, wire the reader directly to the port.
- Supply voltage - Confirm that the voltage is within specification. (see table)
- User token - Confirm that the user token used for testing is OK by presenting it to a known working reader.
- Interference - Confirm whether the reader works when tested 'in hand' and not mounted on the wall. Ensure PROXIMITY readers are not mounted back to back and there is no interference from other RF devices.

2 - Readers / Keypads - Extending cable.

Only Belden CR9538 / 9540 can be used for cable extensions. CR9538 8 core up to 25 m, CR9540 10 core up to 100 m (maximum). With CR9540, the two additional cores should be used to double up the power.

3 - Net2. What to do if a user has no access - Check the reader LED's when a card is shown.

- No LED's - the reader has no power.
- No change in display - try the card on a known working reader. If there is still no response, replace the card.
- Green LED flashing when a card is presented; check relay 1 LED to check for activity and also the lock wiring.
- Red LED is flashing when a card is presented; check the validity of the user at the PC.
Check user's access level and ensure they should have access by clicking on Current Validity.
Check the 'Valid Until' date and confirm this has not expired.
- Reinstate the ACU from the doors screen. Select the ACU's you wish to reinstate and then click OK.

4 - Switch2 - Adding an additional card pack.

You need to be in possession of the original enrolment card. Present the original enrolment card to the reader and the Amber LED will flash, Green & Red LED's will be off, then present the Enrolment card from the new card pack; the reader will beep and all LED's will be lit. The additional cards will now be valid. Repeat this with each reader and with any additional card packs. Any valid enrolment card can be used to add further packs. This is the same for enrolling function card packs onto a system.

5 - Switch2 - How to reset the controller.

1. Disconnect the power and remove the wires from the Green and Mauve terminals.
2. Insert a wire link between the Green and Mauve terminals.
3. Reconnect the power (the unit will beep 4 times).
4. Disconnect the power and remove the link wire, reconnect the Green and Mauve wires.
5. Reconnect the power (the unit will beep 3 times per second). The unit is ready to be enrolled.

Suitability

Security-sensitive doors



Accepts customised inserts and bezels



Wet environments



Readers mounted together

300 mm
between
readers

Specifications

Electrical	Min	Max	
Voltage	10V DC	14V DC	
Current		140 mA	
Carrier frequency			125 kHz
Clock and data bit period			600 µs
Environment	Min	Max	
Operating temperatures - all items	-20 °C	+55 °C	
Waterproof			IPX7
Cable length			5 metres
Dimensions	Width	Height	Depth
Reader	70 mm	110 mm	10 mm
Backbox	60 mm	100 mm	25 mm
Read Range	Token	Keyfob	Hands Free Token
	40 mm	25 mm	400 mm

CE0889

The declaration of conformity is available on request. Contact details are provided at: <http://paxton.info/596>

Contents in box

PROXIMITY architectural reader		
Backbox assembly		
Reader insert diagram		
Instruction set		
Fitting kit	Qty	Description
Kit fk1-080	4	No 8 x 1in pozi pan self tapping screw - zinc
	4	35mm wall plugs
	3	M3 x 10 nylon screw
	1	Reader removal tool

This product is not suitable for retail sale. All warranties are invalid if this product is not installed by a competent person.