

TOUCHLOCK compact stainless steel

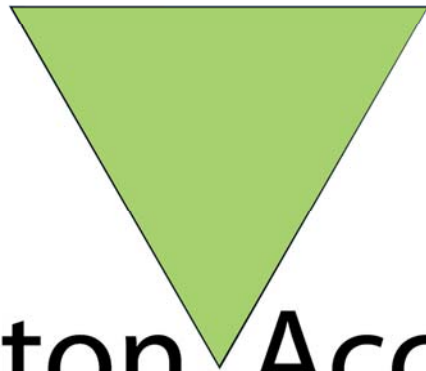

**Paxton Access**

---

# Contents

<b>About</b> .....	<b>3</b>
Features .....	3
Contents in box .....	3
For Stainless steel keypad kit .....	3
<b>Fitting</b> .....	<b>4</b>
Which release?.....	4
Fitting the electric release .....	4
<b>Wiring</b> .....	<b>5</b>
The white wires - Release output .....	5
The green wires - Bell output .....	5
<b>Backup power:</b> .....	<b>5</b>
<b>Commissioning</b> .....	<b>6</b>
Initialising the system .....	6
What is the next step?.....	6
Reset procedure.....	6
<b>Operation</b> .....	<b>7</b>
Programming the keypad.....	7
Single/multiple code mode.....	7
Programming code .....	7
Normal, toggle and duress .....	7
Silent operation .....	7
Lockout.....	7
Data resetting the keypad.....	7
Default Settings .....	7
<b>Applications</b> .....	<b>9</b>
Standard Installation .....	9
Duress alarm.....	9
Exit button .....	10
Time clock.....	10
<b>Tech Help</b> .....	<b>10</b>
<b>Specification</b> .....	<b>11</b>

---

## About

TOUCHLOCK compact stainless steel is a single door, single keypad access control system. The keypad is suitable for internal and external installations. The keypad is suitable for high use applications. The unit is self contained with the control unit, or decision making electronics, housed within the keypad itself. The unit can be powered by both ac and dc 12V power supplies.

**The output to the electric release is 12Vdc solid state limited to 500mA continuous and 750mA intermittent (7 seconds).**

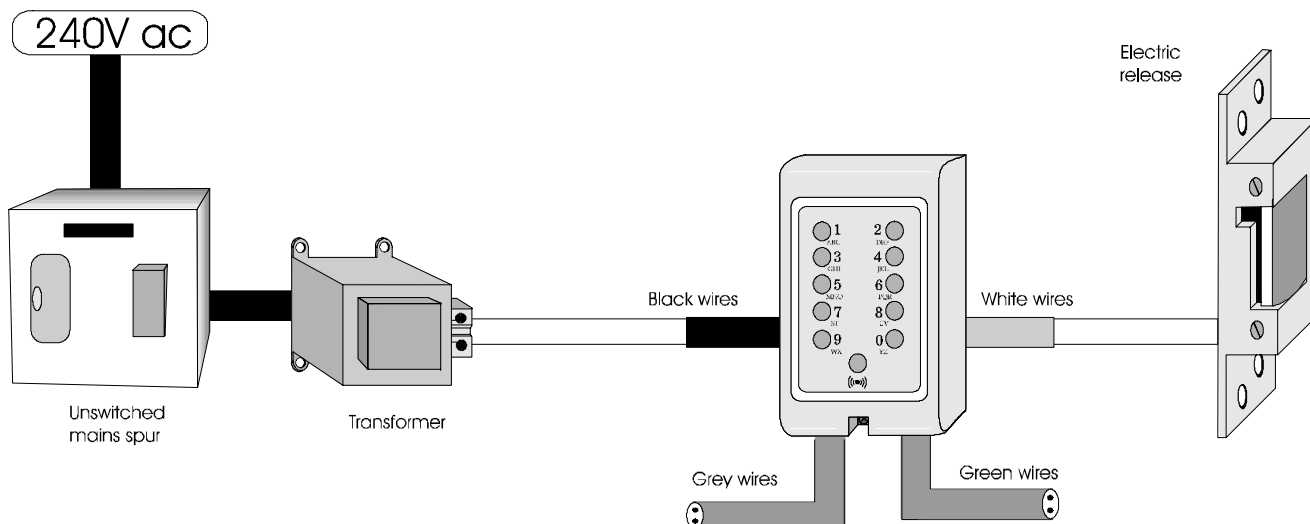

## Features

The unit can be programmed with up to 50 user codes containing 4 - 8 digits each. An exit button may also be connected to the unit.

There are two outputs, one for the electric lock and one that can be used for a door bell/duress alarm see the **TOUCHLOCK programming guide**.

All system settings and the user codes are changed via the keypad.

Any number of TOUCHLOCK systems may be installed on a site.

Switch2 (Sales code 405-321/405-500) is an alternative product that has a separate keypad and control unit. Switch2 has two keypad capability for two way access control, voltage free relay contacts for the electric lock, and increased functionality. For more information contact our technical helpline.

## Contents in box

### For Stainless steel keypad

TOUCHLOCK keypad stainless steel  
Instructions for keypad  
Fitting kit for keypad

### For Stainless steel keypad kit

TOUCHLOCK keypad stainless steel  
Instructions for keypad  
Fitting kit for keypad kit  
12V 1Amp AC transformer  
12V DC fail locked release kit  
Mortice fitting for release  
Rim fitting for release

# Fitting

Using the template provided, mark and drill holes for the cable and the two screws.  
Enlarge the upper part of the cable hole as shown in the diagram below:

- Tap in the wall plugs and screw the top No.8 x 1" posi pan to the wall. Leave the head of the screw about 2mm from the face of the wall.
- Thread the cable through the wall.
- Locate the screw into its keyhole on the back of the keypad and slide the keypad down to engage. Remove and adjust as necessary.
- Tighten down with the bottom No.8 x 1" screw.

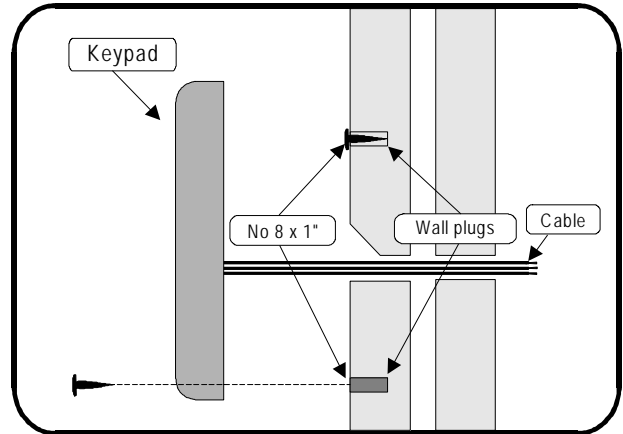

## Which release?

The TOUCHLOCK compact can be used with 12V DC fail open or fail closed releases. Ensure that the release consumes no more than 500mA for continuous use from 12V, or 750mA for intermittent use (7 secs). Please refer to manufacturer's instructions for detail on specific releases.

The TOUCHLOCK compact keypad uses a small residual current to detect the presence of an electric release, used for the data reset procedure. For this reason TOUCHLOCK compact must not be connected directly to a relay coil.

## Fitting the electric release

- Decide on a suitable position for the electric release on the door frame.
- Remove the cover of the release.
- Using the 3.5mm cable clips provided, tack the white cable from the TOUCHLOCK to the release and connect the two wires to the terminals on the release. Polarity does not matter when using a standard 12V DC release.
- Replace the cover of the release.
- If using the rim fitting, do not refit the side plate, this is not used.
- Screw the release to the door frame using the No.8 x 1" screws provided.

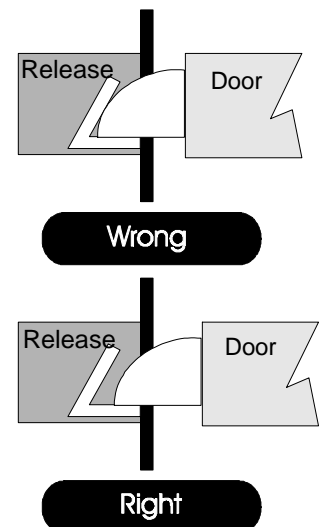
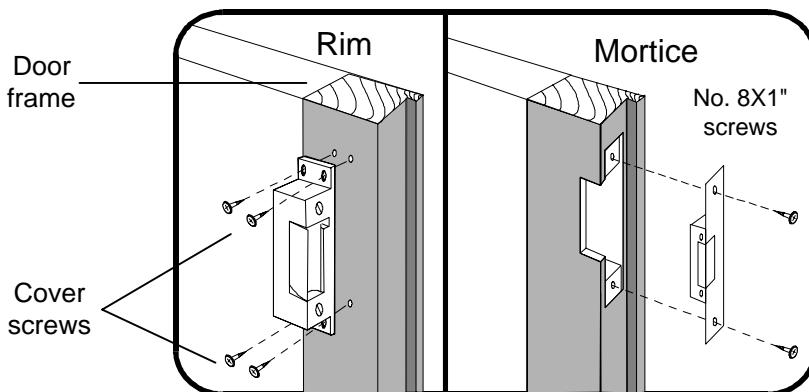

---

# Wiring

## The black wires - Power input

The TOUCHLOCK can be powered with 12 - 15 V AC or DC. On DC systems, the wire marked with a white stripe is positive. When using an AC power supply, the polarity is not important.

## The white wires - Release output

The output is 12V DC. For our standard 12V releases, polarity is not important, but for releases other than this, the wire marked with a black stripe is positive

## The green wires - Bell output

The default setting for these wires is to give a 12V DC output when the doorbell on the keypad is pressed. Alternatively the unit can be programmed to energise the green wires for 30 seconds, when a duress code is entered.

## The grey wires - Exit button

This can be set to operate the release for the door open time or to toggle the release open/shut.

For further wiring details see **Applications**.

---

# Backup power:

If the TOUCHLOCK is powered solely by a transformer, during a power cut, the unit will retain its memory, but will not function for this time.

A backup power supply uses a battery to power the unit in the event of mains power loss. The size of the battery is measured in Ah (Ampere-Hours) and will determine how long the unit can operate using battery power alone. For example:

A TOUCHLOCK is operating in fail open mode, drawing around 50mA. The maglock that it is operating draws around 450mA. This gives us a total of 500mA or 0.5A. If the backup battery fitted is rated at 1Ah, then substituting these figures into the equation below gives us a backup power time of 1 hour and 36 minutes.

$$\text{Backup Power Time} = \frac{\text{Battery Capacity (Ah)}}{(\text{TOUCHLOCK current} + \text{lock current}) \text{ (A)}} \times 0.8$$

The figure, 0.8, in the equation above is a safety factor and is included because the battery cannot supply full power for the last 20% of its life.

If the TOUCHLOCK is operating a fail closed release, then the backup power time is longer.

---

# Commissioning

## Initialising the system

After the system has been wired up, be sure to check over the connections against the wiring diagrams provided before powering up for the first time. When the system is powered up for the first time the keypad will beep 3 times a second. This indicates that the keypad is waiting to be initialised. The red and amber LEDs will be off and the green LED will be flashing.

- **Press the bell button**

*(The unit will stop beeping and the green LED flashes faster)*

- **Enter your chosen 6 digit programming code\* and press the bell button.**

*(The green LED will flash faster still)*

- **Confirm your chosen programming code by entering the same 6 digit code and pressing the bell button.**

*(The green LED goes out and the unit will acknowledge that the programming code has been accepted by beeping twice after a 2 short pause. All the LEDs are now on)*

**\* Note that the programming code SHOULD NOT have the sequence of numbers 1234 in, as this is the default user code**

## What is the next step?

The keypad/s should now work with the user code 1234. The programming code you just entered will now let you into programming mode, where additional alterations can be made. The system will work according to the default settings (See **Operation – TOUCHLOCK**).

Check the system operates correctly using the default settings.

- **Type in the user code 1234**

*(The green LED will flash on the keypad/s and the lock output will activate for 7 seconds)*

- **Type in the programming code you set**

*(There will be 2 beeps to confirm that the correct programming code has been entered and the green LED will flash)*

- **If a buzzer/bell is connected, press the bell button.**

*(The buzzer/bell will sound for as long as the bell button is held down on the keypad)*

- **If an exit/remote button is connected, press it.**

*(The lock output will activate for 7 seconds and the keypad will beep once)*

- **Check that the keypad beeps each time a number button is pressed on the keypad.**

- **Check that lockout is disabled by pressing more than 20 buttons in a sequence that does not include the user or programming code.**

## Reset procedure

The TOUCHLOCK will remember its settings in the event of a power cut. To return the unit to the factory default settings, a data reset must be done. For a list of the factory settings, see **initialising the unit**. The procedure for doing this is outlined as follows:

- Turn off the power to the unit.
- Disconnect the white wires and ensure that the green and grey wires are not shorting together.
- Hold down the '3' button on the keypad and re-administer power to the unit. When the power is applied, release button '3'.
- 3 beeps will indicate that the unit has successfully data reset

**The keypad should now beep 3 times a second.** (The green LED will be continually flashing)

<p><b>NOTE:</b> If the correct programming procedure is not followed the red LED will flash and the keypad will exit the procedure.</p>
---

---

# Operation

## Programming the keypad

The TOUCHLOCK compact SS keypad can be programmed using the master code. To understand each setting, read the following explanations. For more information on how to program each setting, refer to the **TOUCHLOCK Programming Guide**.

## Single/multiple code mode

By default the keypad will operate in single code mode, only allowing one 4-8 digit code to operate the door. It is possible to change this code as many times as are needed. If more than one code is required then the unit can be programmed for multiple codes (up to 50). Again, each code can be 4-8 digits long. In either mode it will be possible to set the code as a toggle, normal or duress code. Codes can be easily deleted.

**\* Note that increasing the number of digits in the user code decreases the chance of the code being guessed by someone randomly pressing keys.**

## Programming code

This code is used to enter the programming procedure for the keypad. It is set during the initialisation of the unit and can be changed later if necessary.

## Normal, toggle and duress

The default user code (1234) will be a Normal code. By this we mean it will operate the lock output will activate for the door open time. A code can also be programmed in as a Toggle code. This means every time the correct code is entered, the lock output will change state eg. 0V – 12V. Lastly, the code could be programmed in as a Duress code. When this code is entered the lock output will activate for the door open time and the bell output will be activated for 30 seconds.

## Silent operation

By default the keypad unit will beep when a button is pressed. This can be turned off if necessary. When turned off the keypad does not emit a beep unless it is in programming mode.

## Lockout

By default the lockout feature is disabled. To decrease the risk of someone guessing the code by randomly pressing the buttons, lockout can be enabled. If lockout is enabled and someone enters more than 20 incorrect digits, the keypad will stop working completely for 60 seconds. **This time cannot be altered.** Once this time is elapsed the keypad will operate normally.

## Door open time

The door open time will be set to 7 seconds as default. This is the time the lock output will stay activated for, once either a correct code is entered or an exit button has been pressed. The time can be changed to suit the situation and can be set to anything from 1 to 60 seconds.

## Remote button

An exit/remote button can be connected to the grey wires. It can be set-up to work in one of 2 ways. The button can be programmed to activate the lock output for the door open time. This is set as default. The button can also be programmed to toggle the lock output.

## Data resetting the keypad

The keypad can be reset to the default conditions below. It can either be reset from the keypad by following the programming guide or by following the procedure below.

## Default Settings

User code.....	1 2 3 4
Master code.....	set when unit is initialised
Code mode.....	Single
Squeak setting .....	Activated
Door open time .....	7 seconds
Remote button.....	Activate lock output for door open time
Lockout mode.....	Lockout disabled

# TOUCHLOCK programming guide

X X X X X X

6 digit programming code

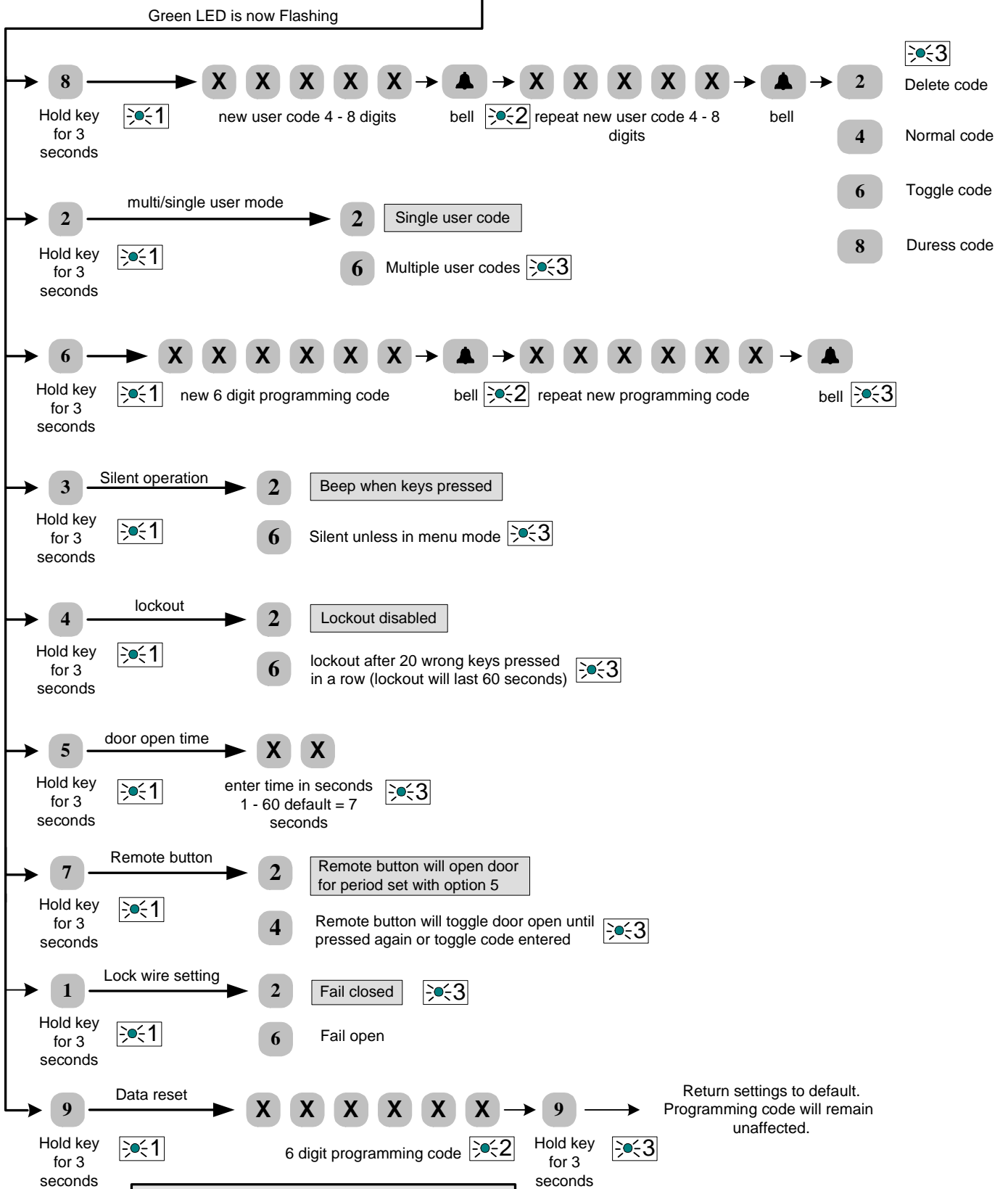

Key:

- LED flashes faster = Green LED flashes faster
- LED flashes faster still = Green LED flashes faster still
- LED goes out then all LEDs on = Green goes out then all LEDs on



# Applications

## Standard Installation

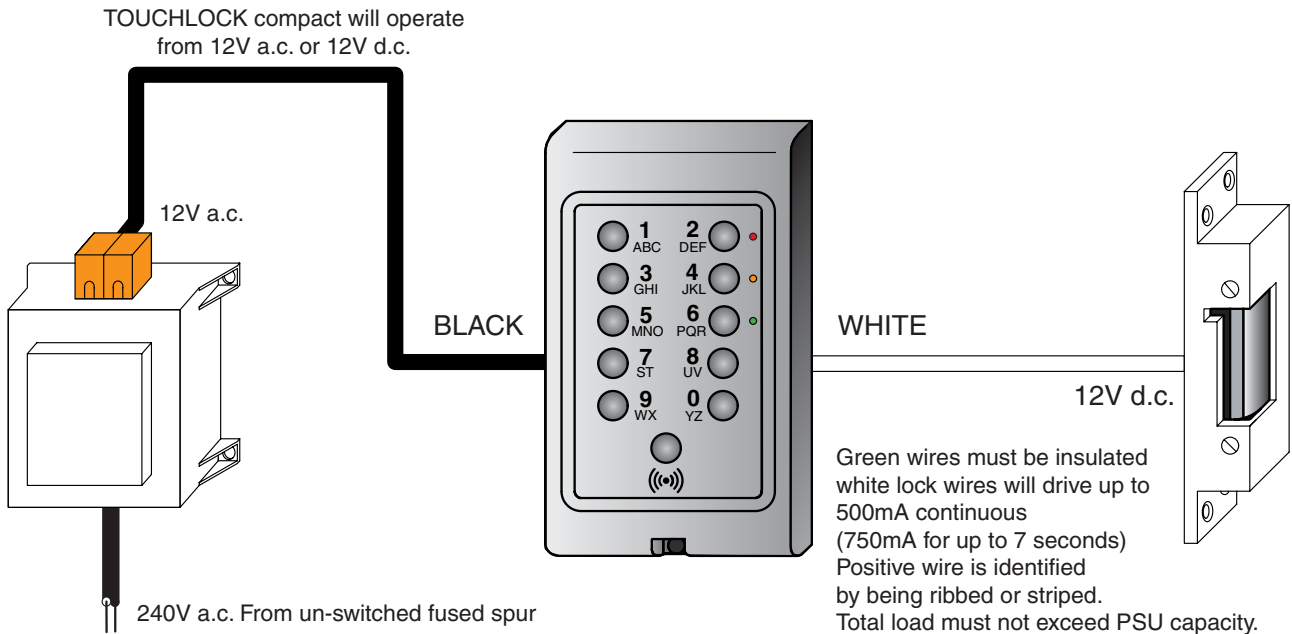

If the correct code is typed in the release is powered and the door unlocks.

## Duress alarm

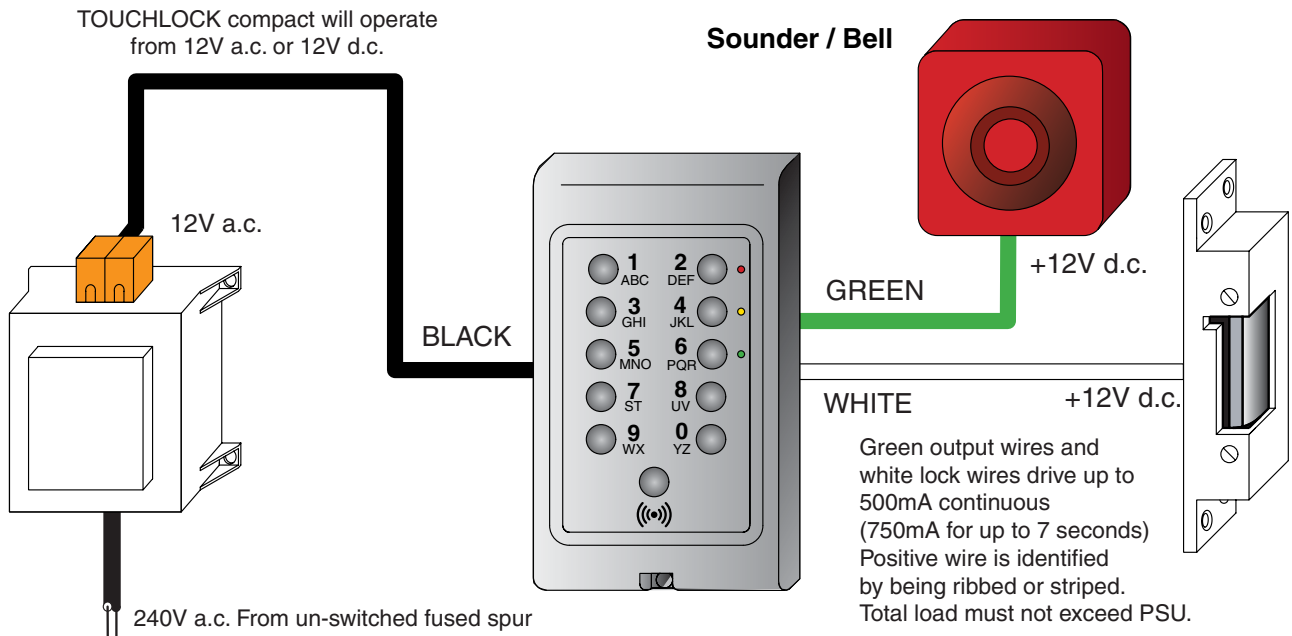

Duress codes can be programmed into the keypad. When a duress code is entered the lock output will activate for the door open time and the bell output will be activated for 30 seconds.

## Exit button

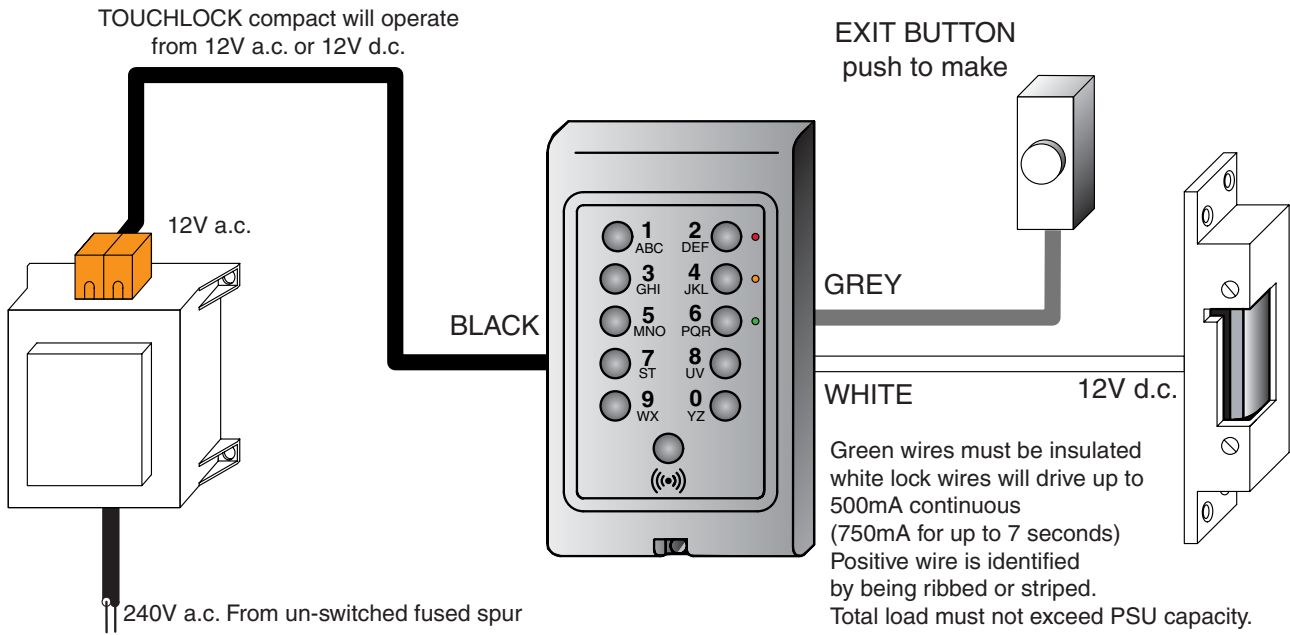

An internal push-to-make button can be used where electronic exit is required. When the button is pressed the doors electric release is activated. Any number of exit buttons can be fitted.

## Time clock

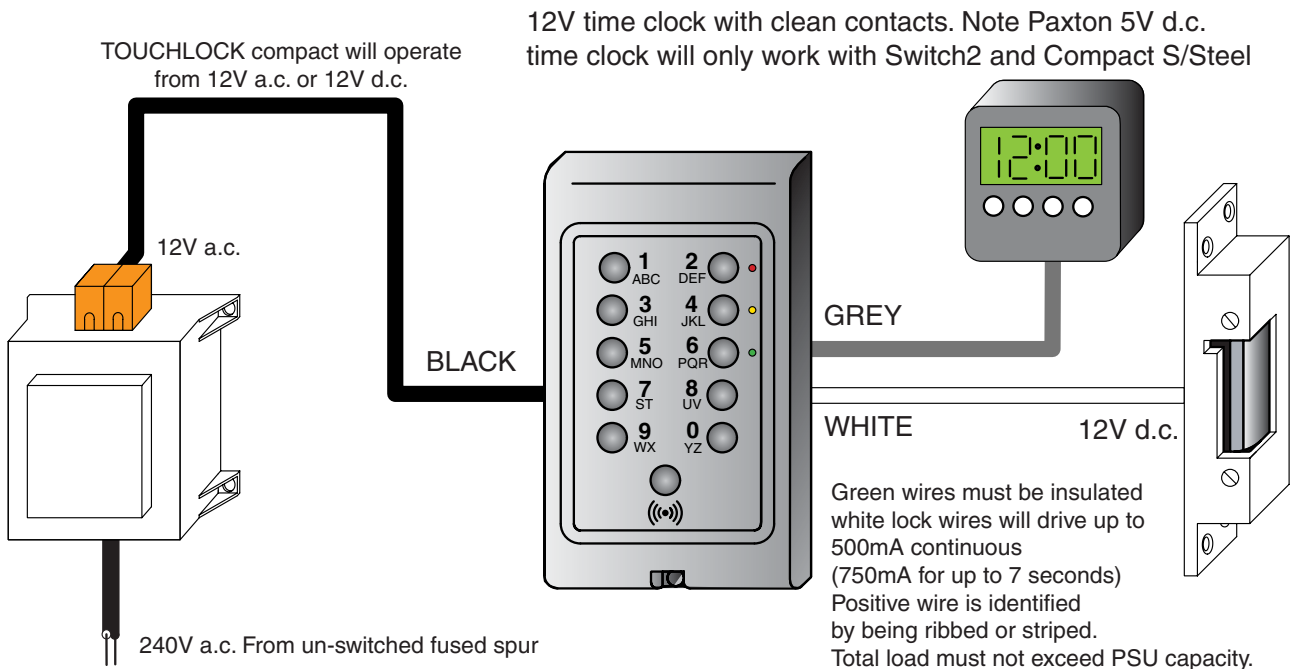

Where a door needs to be held open automatically a time clock can be wired into the keypad as shown above. The voltage free contact outputs from the time clock would be connected to the grey wires of the keypad. A standard central heating timer can be used.

## Tech Help

Feel free to contact the Technical help line from **7:00am – 7:00pm on 0870 6080886**

You can contact us by e-mail – [support@paxton-access.co.uk](mailto:support@paxton-access.co.uk).

Our web site address is <http://www.paxton-access.co.uk>

---

# Specification

User codes.....	up to 50 codes 4 to 8 digits
Keypad construction .....	stainless steel
Keypad finish .....	stainless steel
Second (out) keypad can be added.....	No
Exit button .....	Yes
Card plus code (Needs Switch2 405-321) .....	Yes
Sounder connection (for bell button) .....	Yes
Duress code .....	Yes
Lock out after 20 incorrect digits .....	programmable
Silent operation .....	Yes
Door open time .....	1 to 60 seconds
Fail open (fail safe) locks.....	Yes
Operates a relay .....	No
Toggle code.....	Yes
Water resistance .....	IPX7 (submersible)
Operating temperature .....	- 20°C to 70°C
Size of keypad .....	130 x 75 x 19mm
Cable .....	Twin flex (black, white, grey & green)
Cable length supplied .....	3m
Keypad life.....	>1,000,000 presses
Supply voltage .....	9V to 15V AC or DC
Continuous output current.....	500mA
Output current up to 7 seconds .....	750mA
Output for sounder .....	500mA
Quiescent current.....	80 to 100mA

