

CTR41 CONTROL PANEL FOR DRAWING MOTOR

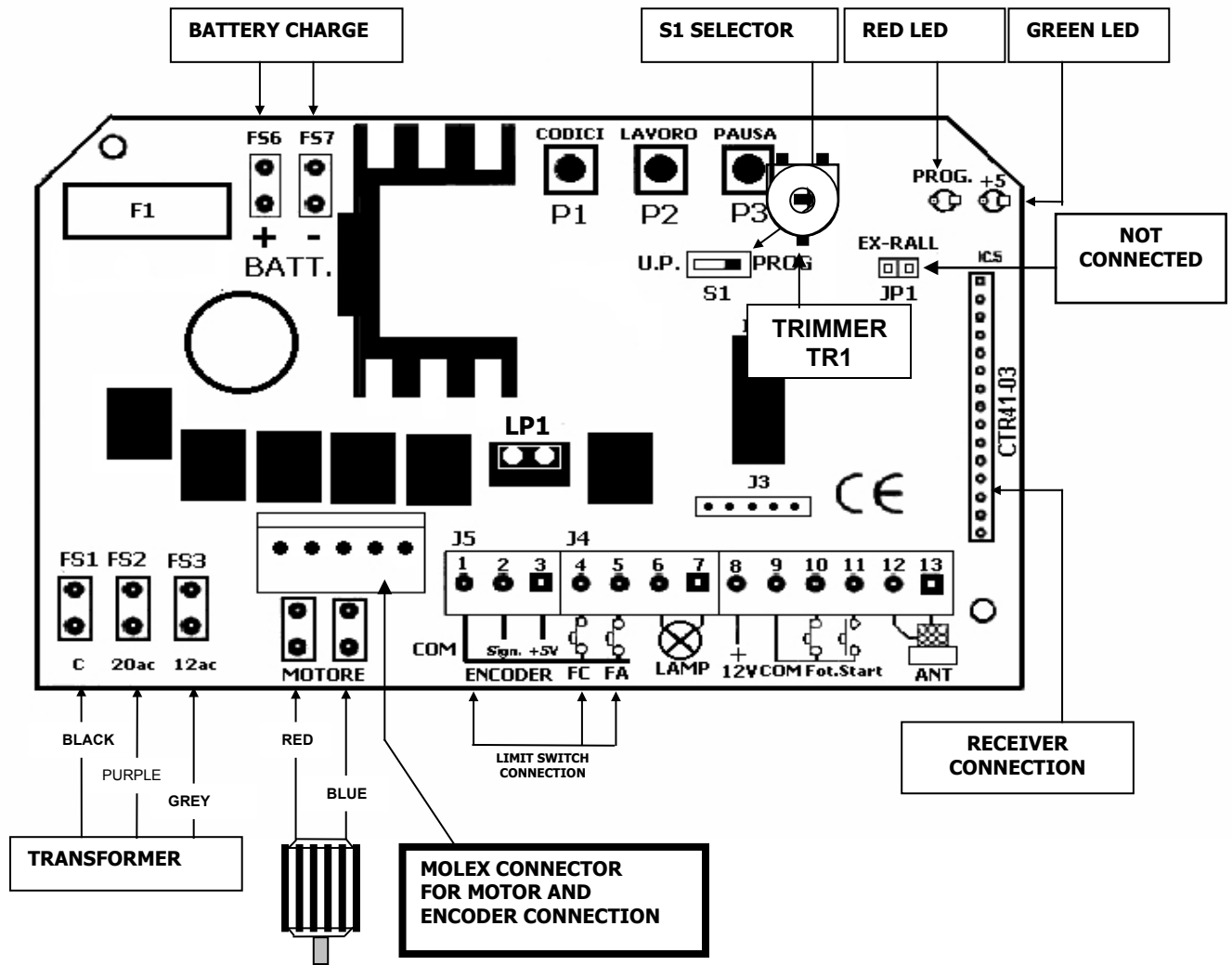

CLAMP	CAPTION	FUNCTION	SETTING
FS1	0	BLACK WIRE TRANSFORMER	0Vac
FS2	20ac	PURPLE WIRE TRANSFORMER	20Vac
FS3	12ac	GREY WIRE TRANSFORMER	12Vac
FS4	MOTOR	RED WIRE MOTOR	POSITIVE POLE
FS5	MOTOR	BLUE WIRE MOTOR	NEGATIVE POLE
1	COM	COMMON ENTRY FOR ENCODER AND F.C. (WHITE WIRE)	
2	SIGN	SIGNAL ENTRY FOR ENCODER (GREEN WIRE)	
3	+5V	POWER SUPPLY ENTRY FOR ENCODER (BROWN WIRE)	
4	FC	LIMIT SWITCH CONTACT CLOSING	N.O.
5	FA	LIMIT SWITCH CONTACT OPENING	N.O.
6	LAMP	POWER SUPPLY WARNING LAMP	0Vac
7	LAMP	POWER SUPPLY WARNING LAMP	12Vac
8	+12	POWER SUPPLY PHOTOCELLS	12Vdc
9	COM	COMMON ENTRY FOR POWER PHOTOCELLS AND CONTACTS	0Vdc
10	FOT	PHOTOCELL CONTACT	N.C.
11	START	START BUTTON	N.O.
12	ANT	ANTENNA WIRE SHIELD (CALZA)	
13	ANT	ANTENNA CENTRAL WIRE	
	LP1	POWER SUPPLY COURTESY LAMP	24Vac

NB. THE J3 CLUTCH MUST NOT BE USED IN ANY CASE

Factory settings

The control unit has two functioning modes: the **ENCODER MODE** and the **F.C. (closing limit switch) MODE**.

The unit is supplied as standard in the F.C. mode

The F.C. mode makes functioning possible only with electromechanical F.C. (N.C.).

To change modes, press down buttons P2 and P3 at the same time, until the red led flashes three times. Release the two buttons and then immediately select the functioning mode by pressing the buttons as follows:

P1 for the **ENCODER** mode or **P2** for the **F.C.** mode.

NB. Allow the door to run its total run after each change.

"Dead man" mode: during installation, verify that the "door" slides perfectly. To do this, move the **S1** selector to the "U.P." position and use the **P1** button to close and the **P2** to open. NB. In the case of electromechanical F.C. functioning, check that the 2 polars do not touch the microswitch.

Setting the door run: In the ENCODER mode, completely open the door, turn the S1 selector to the "PROG" position, press the **P2** button until the red LED switches on and the motor is activated to close the door, then release the **P2** button. When the door is completely closed, press the **P2** button again (during activation of the motor, absorption levels and working speed are calculated). If the electromechanical limit switch is assembled onto the motor, proceed with its adjustment using the two sliding polars.

In the LIMIT SWITCH (F.C.) mode, completely close the door and adjust the closing limit switch. Completely open the door and adjust the opening limit switch. Turn the S1 selector to the "PROG" position and hold the **P2** button until the door begins to close. At the end of the run, the motor will stop automatically and the run is set.

Programming the closing approach mode (ONLY WITH ENCODER)

This programming is necessary to establish the movement and approach mode of the door during the closing phase.

Program 1- Switch off the power supply from the control unit. Press the **P1** button whilst once again switching on the power and release the **P1** button after approximately 3 seconds. With this program the door will slowly move until it is completely closed. **(standard factory setting)**

Program 2- Switch off the power supply from the control unit. Press the **P2** button whilst once again switching on the power and release the **P2** button after approximately 3 seconds. With this program the door will slowly move until it is completely closed and will undergo further pressure from the motor provoking a slow-down in the chain, to be subsequently withdrawn.

Step by step functioning: At each START command activated via the key selector or transmitter, the door will carry out the following cycle: **OPEN – STOP – CLOSE – STOP.**

Automatic functioning: The door is opened at the first START command. Any START commands then made during the opening phase of the door will cause it to stop. At the end of the run, the door will close automatically after the pre-set PAUSE time. A START command effected during the PAUSE time will cause the door to close. A START command effected during the closing phase will cause the door to stop. Intervention of the photocell does not influence the opening phase whilst during the closing phase it causes stoppage and consequent reopening.

Setting the remote control codes: Turn the S1 selector to the "PROG" position and press the **P1** button once; this will cause the LED to flash. When the LED is properly switched on (no flashing), press the remote control button to be set for at least one second. **Re-setting the codes:** press the **P1** button until the LED switches off (approximately ten seconds).

Setting pause time: Turn the S1 selector to the "PROG" position, press the **P3** button until the LED is switched on (no flashing), release the button for a period of time equal to the desired pause time and then once again press the **P3** button.

Re-setting pause time: Turn the S1 selector to the "PROG" position, press the **P3** button until the led switches off (approximately ten seconds). By resetting the pause time, the step by step functioning mode is automatically set.

PROGRAMMIN G THE AMPEROMETRICAL THRESHOLD BY TRIMMER TR1

This programming is to establish sensitivity in the presence of obstacles, both during the closing and the opening phases. The higher the value (e.g. 7A), the more power the motor transmits to the door.

NB. The presence of an obstacle during the opening phase will cause the door to stop and remain blocked until a new START command is effected.

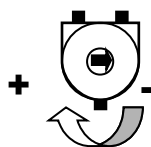

MANUAL SWITCHING ON OF THE COURTESY LAMP USING REMOTE CONTROL

NB. This procedure is not obligatory for the functioning of the motor.

It is possible to pilot the courtesy lamp placed in the motor using a two-channel transmitter. Turn the **S1** selector to the **PROG** position. Press the **P1** button twice and wait till the red LED on the control unit is switched on (no flashing) and transmit the code to be set using the second button on the remote control. Once the code has been set, the second button of the transmitter can be used to switch on the courtesy lamp for a non-variable time of 60 seconds.

N.B. IN CASE OF MALFUNCTION, RESET THE CONTROL UNIT BY SWITCHING OFF THE POWER SUPPLY FOR A FEW SECONDS AND THEN RE-PROGRAMMING.

For installation, comply with UNI 8612 and CEI standards regarding work safety.
Always use a 16A differential switch and 0.030 A threshold.
The product must be installed by qualified personnel in compliance with Law n. 46 of 5th March 1990 and its subsequent modifications.

