

FIBARO DIMMER 2 FGD-212

CONTENTS

v1.3 - firmware 3.5

#1: Description and features	4	#9: Associations	17
#2: Supported loads	5	#10: Z-Wave range test	18
#3: FIBARO Bypass 2 (FGB-002)	7	#11: Error modes	19
#4: Installation	8	#12: Additional functionality	21
#5: Adding/removing the device	11	#13: Advanced parameters	22
#6: Operating the device	12	#14: Specifications	33
#7: Calibration	15	#15: Regulations	34
#8: Power and energy consumption	16		

Important safety information



Read this manual before attempting to install the device!

Failure to observe recommendations included in this manual may be dangerous or cause a violation of the law. The manufacturer, Fibar Group S.A. will not be held responsible for any loss or damage resulting from not following the instructions of operating manual.



Danger of electrocution!

Dimmer 2 is designed to operate in electrical home installation. Faulty connection or use may result in fire or electric shock.

All works on the device may be performed only by a qualified and licensed electrician. Observe national regulations.

Even when the device is turned off, voltage may be present at its terminals. Any maintenance introducing changes into the configuration of connections or the load must be always performed with disabled fuse

General information about the FIBARO System

FIBARO is a wireless smart home automation system, based on the Z-Wave protocol. All of available devices can be controlled through a computer (PC or Mac), smartphone or tablet. Devices are not only receivers, but can also repeat the signal, increasing the Z-Wave network's range. It gives advantage over traditional wireless systems that require direct link between transmitter and receiver, as a result the construction of the building could affect network's range negatively.

Every FIBARO network has its unique identification number (home ID). Multiple independent networks can exist in the building without interfering. Transmission security of FIBARO System is comparable to wired systems.

Z-Wave technology is the leading solution in smart home automation. There is a wide range of Z-Wave devices that are mutually compatible, independently of manufacturer. It gives the system the ability to evolve and expand over time. For more information visit: www.fibaro.com.

#1: Description and features

Remotely controlled light dimming module is designed to work with various types of light sources. It may be connected to two-wire or three-wire configuration so it can operate with or without neutral lead. FIBARO Dimmer 2 can switch or dim connected light source either through radio waves or through the wall switch connected directly to it.

New FIBARO Dimmer 2 is equipped with an algorithm of smart light source detection which makes configuration easier and ensures high compatibility of the device. It may be used as a switch with non-dimmable light sources (in 3-wire connection).

i NOTE

This device may be used with all devices certified with Z-Wave certificate and should be compatible with such devices produced by other manufacturers.

Main features of FIBARO Dimmer 2:

- Compatible with any Z-Wave or Z-Wave Plus Controller,
- Controlled by FIBARO Home Center or any other Z-Wave controller,
- Advanced microprocessor control,
- Implemented algorithm of smart light source detection,
- Auto-adjustment of the appropriate control mode to connected load,
- Active power and energy metering functionality,
- Soft start function,
- Memory of the last lighting level settings,
- Works with various types of switches – momentary, toggle, three-way, etc.
- Active element: semiconductor electronic switch,
- To be installed in wall switch boxes of dimensions allowing for installation, conforming to provisions of applicable regulations,
- FGD-212 is an extension unit.



FIBARO Dimmer 2 is a fully compatible Z-Wave Plus device.

#2: Supported loads

As a dimmer it operates under the following loads:

- 230V operated conventional incandescent and halogen light sources
- 12V operated ELV halogen lamps and dimmable LED bulbs (with electronic transformers)
- 12V operated MLV halogen lamps (with ferromagnetic transformers)
- dimmable LED bulbs
- dimmable compact fluorescent CFL tube lamps
- supported dimmable light sources (power factor > 0.5) with minimal power of 5VA using FIBARO Bypass 2 (depending on the type of load)

Without dimming function it may work with:

- compact fluorescent CFL tube lamps with electronic ballast
- fluorescent tube lamps with electronic ballast
- LED bulbs (power factor > 0.7)
- supported light sources (power factor > 0.5) with minimal power of 5VA using FIBARO Bypass 2 (depending on the type of load)



Applied load and the Dimmer 2 itself may be damaged if the applied load is inconsistent with the technical specifications!

When connecting FIBARO Dimmer 2 act in accordance with the following rules:

- Do not connect loads greater or less than those recommended,
- Do not connect different types of light sources simultaneously,
- Do not connect the power supply without a load,
- Do not connect more than one transformer with Dimmer 2 output,
- When using magnetic transformer load it with 50% of its nominal power at minimum,
- Minimize number of electronic transformers in a circuit, noises caused by them in electrical grids may affect Dimmer's operation.



CAUTION

FIBARO Dimmer 2 supports only compact fluorescent tube lamps and fluorescent tube lamps with electronic ballast. Do not connect other types of fluorescent lamps!



NOTE

You will find more about FIBARO Bypass 2 in chapter #3 on page 7.



i NOTE

Some types of the LED bulbs and compact fluorescent lamps are designed to work in leading edge operating mode.

FIBARO Dimmer 2 uses different operating modes to control following types of loads:

- „Trailing edge“ for resistive loads (R)
- „Trailing edge“ for resistive-capacitive loads (RC)
- „Leading edge“ for resistive-inductive loads (RL)

Recommended values of power for supported loads:

Supported load types		220-240V~
	Resistive loads Conventional incandescent and halogen light sources	50-250W
	Resistive-capacitive loads Fluorescent tube lamp (compact / with electronic ballast), electronic transformer, LED	50-200VA
	Resistive-inductive loads Ferromagnetic transformers	50-220VA

#3: FIBARO Bypass 2 (FGB-002)

FIBARO Bypass 2 (FGB-002) is a device designed to work with FIBARO Dimmer 2 (FGD-212). It should be used in case of connecting LED bulbs or energy saving compact fluorescent lamps. FIBARO Bypass 2 prevents flickering of the LED lights and glowing of the turned off compact fluorescent lamps.

In the case of 2-wire connection, FIBARO Bypass 2 allows to reduce minimum power of load required by the Dimmer 2 for correct operation. FGB-002 provides powering of the Dimmer 2 in case of controlling the low loads of minimum power down to 5VA (for $\cos\phi > 0.5$).

Device installation:

1. Switch off the mains voltage (disable the fuse).
2. Connect the Bypass 2 in accordance with „Installation“ on page 8.
3. Follow the Dimmer 2 installation.
4. Force the calibration procedure with FIBARO Bypass 2 using RED menu position (see „Operating the device“ on page 12) or through setting parameter 13 to 2 (see „Advanced parameters“ on page 22).

Specifications:

Power supply:	100-240 V~ 50/60 Hz
Operational temperature:	0-35°C
Dimensions (L x W x H):	31 x 21,6 x 13 mm
Power consumption:	< 1,4 W

CAUTION

Dimmer 2 was designed to work only with FGB-002. Connecting other devices may cause damage to the Dimmer 2.

CAUTION

In the case of 2-wire connection do not connect load below minimal power without FGB-002.

CAUTION

Bypass 2 works only with Dimmer 2 in trailing edge mode. Do not connect the Bypass to the Dimmer operating in leading edge mode.

CAUTION

Bypass 2 is sensitive to the frequent changes of the state of Dimmer 2 (alternate switching on and off). Significant changes in brightness should not be performed more than once per second.

#4: Installation



Connecting the FIBARO Dimmer 2 in a manner inconsistent with manual may cause risk to health, life or material damage.

When connecting FIBARO Dimmer 2 act in accordance with the following rules:

- Connect only in accordance with one of the diagrams,
- Dimmer 2 should be installed in a wall switch box compliant with a relevant national safety standards and with depth no less than 60mm,
- Electrical switches used in installation should be compliant with the relevant safety standards,
- Length of wires used to connect the control switch should not exceed 20m.

Notes for the diagrams:

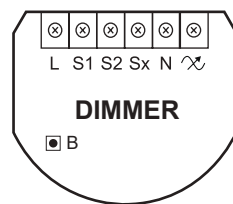

L - terminal for live lead

S1 - terminal for switch no. 1 (has the option of entering the device in learning mode)

S2 - terminal for switch no. 2

Sx - terminal for power supply to the switch connected to the Dimmer 2

N - terminal for neutral lead

 - output terminal of the Dimmer 2 (controlling connected light source)

B - service button (used to add/remove the device and navigate the menu)

Installation of the FIBARO Dimmer 2:

1. Switch off the mains voltage (disable the fuse).
2. Open the wall switch box.
3. Connect with one of following the diagrams:

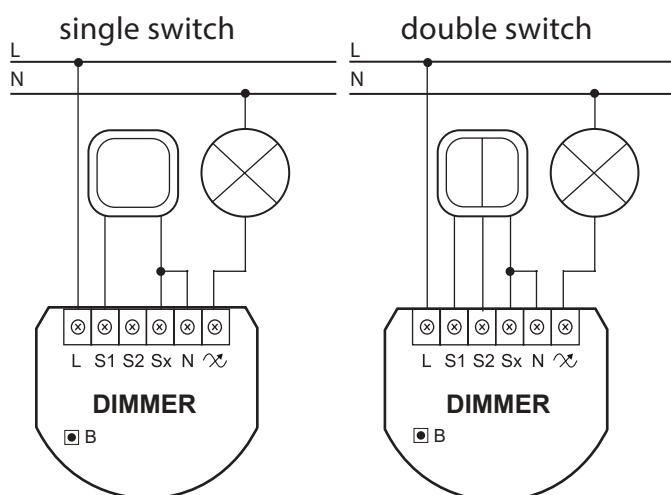

Wiring diagram no. 1 - 2-wire connection

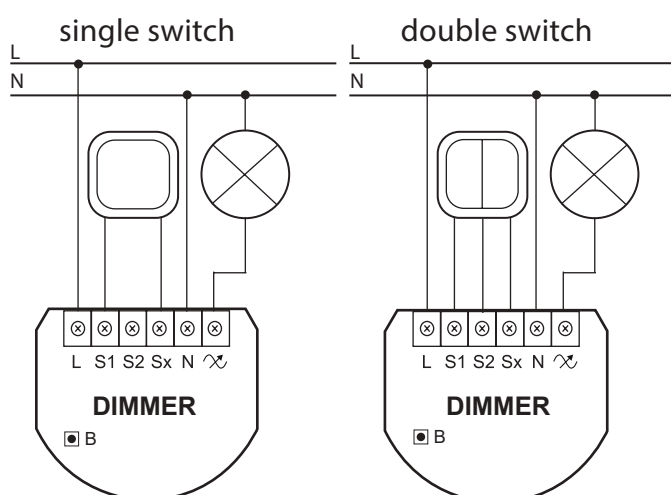

Wiring diagram no. 2 - 3-wire connection

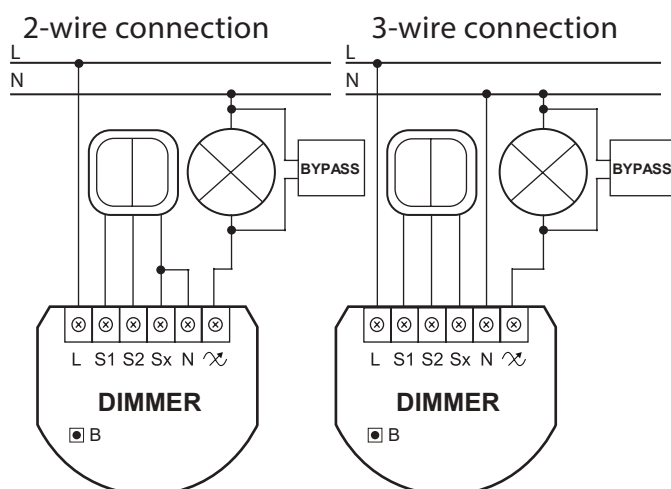

Wiring diagram no. 3 - connecting FGB-002

i NOTE

Switch connected to the S1 terminal is a master switch. It activates the basic functionality of the Dimmer 2 (turning the light on/off, dimming) and starts the learning mode (Add/Remove). The switch connected to the S2 terminal is an optional switch and pushing it without changing the configuration parameters will not affect the status of the device. Functionality of the switches can be reversed by adjusting advanced parameter (see „Advanced parameters“ on page 22).

i NOTE

It is not recommended to install different types of wall switches (momentary, toggle, etc.) in a 3-way connection.

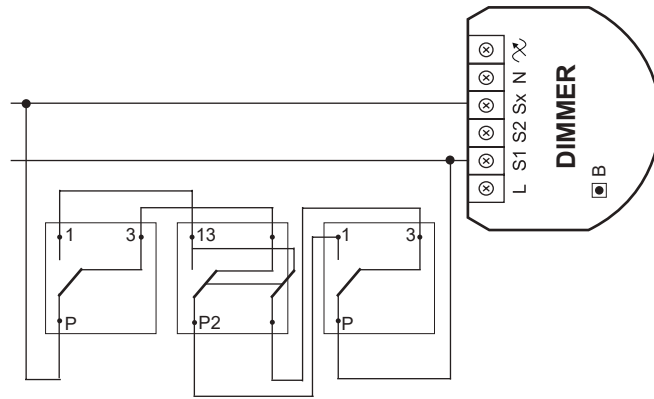

Wiring diagram no. 4 - 3-way switch connection

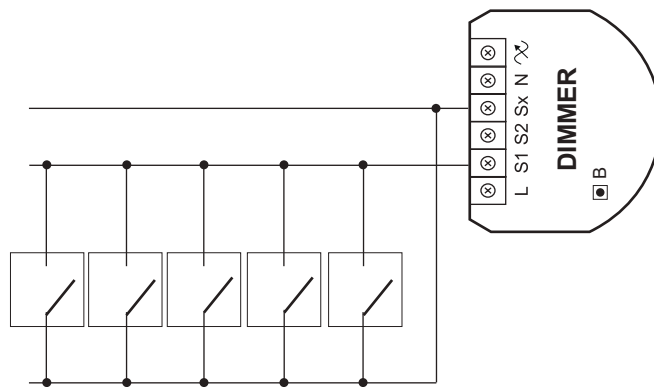

Wiring diagram no. 5 - momentary wall switches connection

i NOTE

After switching on the mains voltage LED indicator will signal Z-Wave network inclusion state with a colour:

GREEN - device added
RED - device not added
RED/GREEN ALTERNATELY - Z-Wave error

4. After verifying correctness of connection switch on the mains voltage,
5. Wait around 30s for the calibration process to end (see „Calibration“ on page 15), light may blink during the process,
6. After successful calibration the device will be turned off by default,
7. Add the device to the Z-Wave network (see „Adding/removing the device“ on page 11),
8. Turn off the mains voltage, then arrange the device and its antenna in a wall switch box,
9. Close the wall switch box and turn on the mains voltage.

Tips for arranging the antenna:

- Locate the antenna as far from metal elements as possible (connecting wires, bracket rings, etc.) in order to prevent interferences.
- Metal surfaces in the direct vicinity of the antenna (e.g. flush mounted metal boxes, metal door frames) may impair signal reception!
- Do not cut or shorten the antenna - its length is perfectly matched to the band in which the system operates.

#5: Adding/removing the device

Adding (Inclusion) - Z-Wave device learning mode, allowing to add the device to existing Z-Wave network.

To add the device to the Z-Wave network:

1. Place the Dimmer 2 within the direct range of your Z-Wave controller.
2. Identify switch no. 1 (turns the light on) or the B-button (located on the device's housing).
3. Set the main controller in (security/non-security) add mode (see the controller's manual).
4. Quickly, three times press switch no. 1 or the B-button.
5. Wait for the adding process to end.
6. Successful adding will be confirmed by the Z-Wave controller's message.

Removing (Exclusion) - Z-Wave device learning mode, allowing to remove the device from existing Z-Wave network.

To remove the device from the Z-Wave network:

1. Place the Dimmer 2 within the direct range of your Z-Wave controller.
2. Identify switch no. 1 (turns the light on) or the B-button (located on the device's housing).
3. Set the main controller in remove mode (see the controller's manual).
4. Quickly, three times press switch no. 1 or the B-button.
5. Wait for the removing process to end.
6. Successful removing will be confirmed by the Z-Wave controller's message.
7. Dimmer 2 will start the calibration process (see „Calibration“ on page 15).

NOTE

For toggle switches in default configuration perform six position changes.

NOTE

In case of problems related to unknown configuration or type of external switch use the B-button to add/remove.

CAUTION

While adding the Dimmer 2 to the network with connected toggle switch, ensure that all switch contact is open (off). Otherwise it will prevent adding/removing the device to/from the network.

NOTE

Removing the Dimmer 2 from the Z-Wave network restores all the default parameters of the device, but does not reset power metering data.

NOTE

Adding/removing is not possible during the calibration procedure.

NOTE

Adding in security mode must be performed up to 2 meters from the controller.

#6: Operating the device

Controlling the Dimmer 2 using a switch:

Momentary switch (after releasing the switch a spring automatically pushes back and disconnects the switch):

- Turning the light ON/OFF: change the position of switch no. 1. The Dimmer 2 will be activated always at previously set brightness level,
- Brightening/dimming the light: hold switch no. 1 down. When the switch is held down, the Dimmer 2 will always reach the extreme value of 1% or 99%,
- Turning the light ON completely: fast double-click switch no. 1. The Dimmer 2 will set the load at 99%.

Toggle switch (operates as a two-position switch, it has no spring that would set one position of the switch):

- Turning the light ON/OFF: toggle switch no. 1. The Dimmer 2 will be activated always at previously set brightness level,
- Turning the light ON completely: toggle twice switch no. 1. The Dimmer 2 will set the load at 99%.

Controlling the Dimmer 2 using FIBARO Home Center controller:

After adding the Dimmer 2 to the network, it will be represented in the FIBARO Home Center controller by the following icon:



Dimming/brightening is performed by moving the slider. The current status of the Dimmer 2 is shown on the bar indicator.

Turning the device ON/OFF – ON and OFF icons are used for setting the last saved state or turning off the Dimmer 2.

Controlling the Dimmer 2 using a command: ALL ON/ALL OFF in non-secure mode:

The Dimmer 2 responds to commands ALL ON/ALL OFF that may be sent by the Z-Wave controller. ALL ON/ALL OFF commands are usually implemented in the remote controllers using Z-Wave protocol, and they are used to issue commands directed to the entire system.

By default, both commands ALL ON and ALL OFF are accepted. Settings may be changed by modifying the value of parameter 11 (see „Advanced parameters“ on page 22). In this way the user may determine to which commands the device should respond.

Resetting the Dimmer 2:

1. Disconnect the power supply.
2. Remove the Dimmer 2 from the wall switch box.
3. Connect the power supply.
4. Locate the B-button on the housing.
5. Press and hold the B-button to enter the menu mode.
6. Wait for the visual LED indicator to turn yellow.
7. Quickly release and click the B-button again.
8. After few seconds the device will be restarted, which is signalled with the red LED indicator colour.
9. The device enters the calibration mode.

Controlling the Dimmer 2 using the B-button:

FIBARO Dimmer 2 is equipped with a B-button, which allows to use the MENU mode and additionally perform the following actions:

1x click:

- alarm mode cancellation (flashing alarm)
- exit the error mode
- select the desired MENU option (if MENU mode is active)

3x click:

- send the Node Info Z-Wave command frame (adding/removing)

Holding:

- enter the MENU mode (confirmed by the LED indicator)

NOTE

Resetting the device is not the recommended way of removing the device from the Z-Wave network. Use reset procedure only if the primary controller is missing or inoperable. Certain device removal can be achieved by the procedure of removing described in „Adding/removing the device“ on page 11.

MENU mode & visual indications:

FIBARO Dimmer 2 has a MENU with each position indicated by the specified LED indicator colour. In order to enter the menu press the B-button and hold for at least 2 seconds. While the B-button is still pressed, LED indicator colour will change in the following sequence:

BLUE - initiate the load calibration procedure (see „Calibration“ on page 15)

RED - load calibration procedure with FIBARO Bypass 2 (see „Calibration“ on page 15)

WHITE - activate turning the load on/off using the B-button

GREEN - reset the energy consumption data memory (see „Power and energy consumption measurement“ on page 16)

VIOLET - initiate the Z-Wave network range test (see „Z-Wave range test“ on page 18)

YELLOW - reset the FIBARO Dimmer 2 to factory defaults

Release the B-button to choose the desired function and confirm your choice with the B-button click.

#7: Calibration

Dimmer 2 is equipped with an algorithm of smart light source detection. Depending on the connected type of light source, it automatically adjusts an optimal control mode (leading edge for inductive loads, trailing edge for capacitive or resistive loads). The procedure of learning the light source type is called calibration.

Calibration automatically adjusts maximum and minimum light levels (parameter 1 and 2). However, the installer is obliged to verify the proper operation of the device, according to control modes description. There is a small probability that calibration settings will require a manual correction. In a 2-wire connection for loads other than resistive parameter 1 settings must be adjusted manually.

Calibration procedure is performed always after removing the device from the Z-Wave network. If the device is not included, after each power on/off calibration will occur. For the included device, calibration is performed in accordance with the parameter 35 settings.

Calibration may be forced:

- by setting parameter 13 to 1 or 2 (without/with FIBARO Bypass 2)
- through triple clicking and holding the main light switch (each hold for more than 5 seconds)
- by selecting the appropriate MENU option using the B-button (see „Operating the device“ on page 12).

By default, calibration is performed without FIBARO Bypass 2. In case of connecting the Bypass 2, it is required to force the appropriate calibration procedure using B-button menu or through parameter 13. The device saves the last calibration enforcement mode (with or without Bypass 2).

The result of calibration will be confirmed with the LED indicator glowing in one of the following colours:

GREEN - Light source recognized as dimmable, dimming levels set, brightness may be controlled using the S1 switch.

YELLOW - Light source recognized as non-dimmable, possibility to turn ON/OFF connected light with default parameters settings.

RED - Calibration procedure failed. Possible reasons: lack of connected load or connected light source exceeds maximum power, which may be controlled by the Dimmer 2.

BLINKING RED - Calibration procedure failed. Possible reasons: installation failure or damaged load (causing activation of the overcurrent protection).

CAUTION

Some types of LED and CF lamps are designed to operate in leading edge mode (with conventional dimmers). Information about proper operation mode of the bulb should be included in its manual. In this case you have to manually force the desired operating mode using parameter 30.

CAUTION

During the calibration procedure, radio connection is disabled and the Dimmer 2 does not respond to any commands. It may cause temporary problems with communication in the Z-Wave network. After completing the calibration, communication with the module will be restored.

#8: Power and energy consumption

CAUTION

FIBARO Dimmer 2 in the 3-wire connection has the power and energy measurement function. In case of the 2-wire connection this function is available only for load of $\cos\varphi \geq 0.99$. In other cases power is estimated and can differ from actual power consumed by the device.

CAUTION

FIBARO Dimmer 2 stores periodically (every 5 minutes) the consumption data in the device memory. Disconnecting the module from the power supply will not erase the energy consumption data.

NOTE

Power measurement in the 2-wire connection does not include mains voltage fluctuations within +/- 10%.

* Measurements in this case are only illustrative, returned values may differ from the actual measurement. In the case of reporting incorrect values change the values of parameters 58 and 59.

FIBARO Dimmer 2 allows for the active power and energy consumption monitoring. Data is sent to the main Z-Wave controller, e.g. Home Center. Measuring is carried out by the most advanced micro-controller technology, assuring maximum accuracy and precision.

Electric active power - power that energy receiver is changing into a work or a heat. The unit of active power is Watt [W].

Electric energy - energy consumed by a device through a time period. Consumers of electricity in households are billed by suppliers on the basis of active power used in given unit of time. Most commonly measured in kilowatt-hour [kWh]. One kilowatt-hour is equal to one kilowatt of power consumed over period of one hour, 1kWh = 1000Wh.

Resetting consumption memory:

Dimmer 2 allows to erase stored consumption data in three ways:

- By resetting the device (see „Operating the device” on page 12).
- Using functionality of a Z-Wave controller (see the controller’s manual).
- Manually clearing the data using the following procedure:
 - Make sure that the device is connected to the power supply.
 - Press and hold the B-button for a few seconds, until LED indicator glows GREEN.
 - Release the B-button.
 - Press the B-button briefly.
 - Energy consumption memory has been erased.

Table of power measurement accuracy:

FGD-212	3-wire connection		2-wire connection	
	Brightness>70%	Brightness<70%	Brightness>70%	Brightness<70%
resistive load	+/- (0.5 % + 0.2W)	+/- (2 % + 0.2W)	+/- (2 % + 0.2W)	+/- (4 % + 0.2W)
resistive-inductive load	+/- (0.5 % + 0.2W)	+/- (2 % + 0.2W)	Power metering approximate*	Power metering approximate*
resistive-capacitive load	+/- (0.5 % + 0.2W)	+/- (2 % + 0.2W)	Power metering approximate*	Power metering approximate*

#9: Associations

Association (linking devices) - direct control of other devices within the Z-Wave system network using the wall switch connected to the Dimmer 2.

The association enables the Dimmer 2 to control directly a device included in Z-Wave network e.g. other Dimmer, Relay Switch, Roller Shutter or scene (may be controlled only through a Z-Wave controller).

The Dimmer 2 provides the association of five groups:

1st Association Group „Lifeline“ reports state of the device. Main Z-Wave Plus network controller should be added to this group. The „Lifeline“ group can handle only one device. It is not recommended to modify this group.

2nd Association Group „On/Off (S1)“ is assigned to switch no. 1. Sends BASIC command class frame according to the state of the device.

3rd Association Group „Dimmer (S1)“ is assigned to switch no. 1. Sends MULTILEVEL SWITCH command class frame. Allows sending dim/brighten command to associated devices.

4th Association Group „On/Off (S2)“ is assigned to switch no. 2. Sends BASIC command class frame according to the state of the device.

5th Association Group „Dimmer (S2)“ is assigned to switch no. 2. Sends MULTILEVEL SWITCH command class frame. Allows sending dim/brighten command to associated devices.

Dimmer 2 in 2nd to 5th group allows to control 8 regular or multichannel devices per an association group, with the exception of „LifeLine“ that is reserved solely for the Z-Wave controller and hence only 1 node can be assigned.

It is not recommended to associate more than 10 devices in general, as the response time to control commands depends on the number of associated devices. In extreme cases, system response may be delayed.

To add an association (using the Home Center controller):

1. Go to device options by clicking the icon: 
2. Select the „Advanced“ tab.
3. Specify to which group and what devices are to be associated.
4. Wait for the configuration process to end. Sending relevant information to devices added to associated groups may take even a few minutes.

NOTE

Association ensures direct transfer of control commands between devices, is performed without participation of the main controller and requires associated device to be in the direct range.

NOTE

The Dimmer 2 supports the operation of multichannel devices. Multichannel devices are devices that include two or more circuits inside one physical unit.

#10: Z-Wave range test

CAUTION

To make Z-Wave range test possible, the device must be added to the Z-Wave controller. Testing may stress the network, so it is recommended to perform the test only in special cases.

NOTE

Communication mode of the Dimmer 2 may switch between direct and one using routing, especially if the device is on the limit of the direct range.

FIBARO Dimmer 2 has a built in Z-Wave network main controller's **range tester**.

Follow the below instructions to test the main controller's range:

1. Press and hold the B-button until the visual indicator glows violet.
2. Release the B-button.
3. Press the B-button again, briefly.
4. Visual indicator will indicate the Z-Wave network's range (range signalling modes described below).
5. To exit Z-Wave range test, press the B-button briefly.

Z-Wave range tester signalling modes:

Visual indicator pulsing green - Dimmer 2 attempts to establish a direct communication with the main controller. If a direct communication attempt fails, the device will try to establish a routed communication, through other modules, which will be signalled by visual indicator pulsing yellow.

Visual indicator glowing green - Dimmer 2 communicates with the main controller directly.

Visual indicator pulsing yellow - Dimmer 2 tries to establish a routed communication with the main controller through other modules (repeaters).

Visual indicator glowing yellow - Dimmer 2 communicates with the main controller through the other modules. After 2 seconds the device will retry to establish a direct communication with the main controller, which will be signalled with visual indicator pulsing green.

Visual indicator pulsing violet - Dimmer 2 does communicate at the maximum distance of the Z-Wave network. If connection proves successful it will be confirmed with a yellow glow. It's not recommended to use the device at the range limit.

Visual indicator glowing red - Dimmer 2 is not able to connect to the main controller directly or through another Z-Wave network device (repeater).

#11: Error modes

Description of error messages of the Dimmer 2

Events result from installation flaws, faulty light source operation or incorrect manual changes in advanced configuration. The device may stop responding to user's commands and actions, leaving the light source off. Message with information about the type of error is sent by default (using Z-Wave network).

Error messages:

A) OVERTEMPERATURE ERROR

Dimmer 2 features self-temperature measurement function. In case of reaching critical temperature, the load is turned off and the gateway receives an information about exceeding maximum temperature of the module.

B) LOAD ERROR

Dimmer 2 is equipped with functionality of detecting the burnt out bulb. In case of such situation, Dimmer 2 sends the notification about load failure. Described function is not available for values of parameter 58 different than 0.

Power variation is detected in accordance with the settings of parameters 15 and 16.

Example:

Parameter 15 set to 30%.

Parameter 16 set to 5 seconds.

Dimmer 2 will detect the change of load at the moment of power variation by 30% compared to standard power consumption (measured during the calibration) and after 5 seconds from brightness level stabilization.

This function is available only in a control mode compliant with the mode recognized during the calibration (parameter 14 set to 1).

Appearing of an error may be the result of not connecting the load. It may suggest burning out all of the loads connected to the Dimmer 2.

Damaged load should be immediately replaced. After connecting the new load, FIBARO Dimmer 2 will return to normal operation.

C) SURGE ERROR

Appearing of an error may be the result of electrical surges, incorrect load control (inductive load controlled in trailing edge mode) or connecting the prohibited type of load.

NOTE

Pressing any of the connected switches or changing state of the device using the controller will exit error mode.

NOTE

If parameter 35 is set to 3 or 4, the load will be calibrated again after turning on the load or an occurrence of LOAD ERROR, SURGE or OVERCURRENT error.

D) OVERCURRENT ERROR

Appearing of an error may also be the result of rapid powering on the load. It may also occur if the soft-start functionality is disabled (parameter 34 set to 0) or as a result of the short circuit.

If parameter 37 is set to 1, the device will automatically try to turn on again.

If described error has been caused by the rapid powering on the load, then FIBARO Dimmer 2 will return to normal operation after re-enabling.

After three unsuccessful automatic tries of turning on the load, Dimmer 2 will stay in OVERCURRENT error mode (module turned off). In such situation, it is required to remove the failure (possible short circuit in the installation.) Otherwise, it is recommended to set the long soft-start (parameter 34 set to 2).

E) OVERLOAD ERROR

Appearing of an error is a result of connecting receivers with too much power consumption. In this case FIBARO Dimmer 2 will automatically turn off the lighting.

It is required to reduce power consumption of connected load (e.g. by reducing the number of receivers) and turn on the light source again by the wall switch or a Z-Wave command.

F) VOLTAGE DROP ERROR

Appearing of an error in a 2-wire connection may be the result of mains voltage drop or a too high brightness level of the light source.

If parameter 37 is set to 1, the device will automatically try to turn on again.

Voltage drop error suggests that parameter 2 value should be reduced until disappearing of the failure. You can also recalibrate the load using parameter 13.

After three unsuccessful automatic tries of turning on the load, Dimmer 2 will stay in VOLTAGE DROP error mode (module turned off).

G) HARDWARE FAIL ERROR

Appearing of an error may be a result of serious hardware failure of the Dimmer 2. In this case the Dimmer 2 sets the maximum brightness level and the LED visual indicator starts blinking in red. All external actions (Z-Wave commands, pressing the switches, menu settings) will be ignored.

We recommend disconnecting the device from the power supply and contacting the customer service or to initiate the guarantee procedure.

This error may also appear as a result of enabling the Dimmer 2 without load connected to the output in 3-wire connection. It is not a dangerous situation. We recommend disabling the fuse, connecting the load and enabling the fuse again.

#12: Additional functionality

Software update

Dimmer 2 features remote software update (initiated by the main controller). Update status is signalled by the LED indicator with cyan colour:

- **slow blinking** - transferring data via Z-Wave and saving to the flash memory
- **fast blinking** - copying data from the external memory to the memory of the microcontroller

Operating alarm data frames

FIBARO System allows user to set response of devices to alarm situations (response to data-frames ALARM_REPORT and SENSOR_ALARM_REPORT). Dimmer 2 responds to the following types of alarms:

- General Purpose Alarm - GENERAL PURPOSE ALARM
- Smoke Alarm - ALARM CO₂, ALARM CO, ALARM SMOKE
- Water Flooding Alarm - ALARM WATER
- Temperature Alarm - ALARM HEAT

Alarm data-frames are sent by devices that are system sensors (e.g., flood sensors, smoke detectors, motion detectors, etc.).

The device may respond in the following manner to received data-frames (settings are configured in configuration parameters, see „Advanced parameters“ on page 22):

- 0 - **DEACTIVATION** - the device does not respond to alarm data frames
- 1 - **DIMMER 2 ON** - the device turns on after detecting an alarm
- 2 - **DIMMER 2 OFF** - the device turns off after detecting an alarm
- 3 - **ALARM FLASHING** - the device periodically changes its status to the opposite when it detects an alarm (lights on/off alternately)

#13: Advanced parameters

Dimmer 2 allows to customize its operation to user's needs. The settings are available in the FIBARO interface as simple options that may be chosen by selecting the appropriate box.

In order to configure FIBARO Dimmer 2 (using the Home Center controller):

1. Go to the device options by clicking the icon: 
2. Select the „Advanced” tab.

CAUTION
 The maximum brightness level (parameter 2) must be greater than the minimum brightness level (parameter 1).

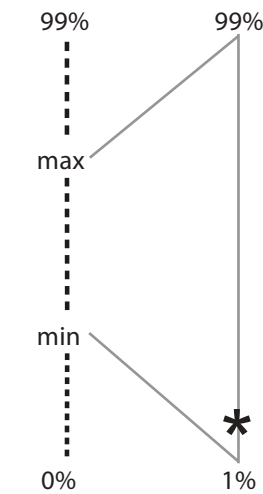

..... real scale
 — scale available to the user (virtual)
 * incandescence level of dimmable compact fluorescent lamps

GROUP 0 - The Dimmer 2 behavior - Basic functionalities

1. Minimum brightness level (parameter is set automatically during the calibration process)

The parameter can be changed manually after the calibration.

Available settings:	1-98 - percentage level of brightness		
Default setting:	1	Parameter size:	1 [byte]

2. Maximum brightness level (parameter is set automatically during the calibration process)

The parameter can be changed manually after the calibration.

Available settings:	2-99 - percentage level of brightness		
Default setting:	99	Parameter size:	1 [byte]

3. Incandescence level of dimmable compact fluorescent lamps

Virtual value set as a percentage level between parameters MIN (1%) and MAX. (99%). The Dimmer 2 will set to this value after first switch on. It is required for warming up and switching dimmable compact fluorescent lamps and certain types of light sources.

Available settings:	1-99 - percentage level of brightness		
Default setting:	1	Parameter size:	1 [byte]

4. Incandescence time of dimmable compact fluorescent lamps

This parameter determines the time required for switching compact fluorescent lamps and certain types of light sources. Setting this parameter to 0 will disable the incandescence functionality.

Available settings:	0-255 (0-25.5s)		
Default setting:	0	Parameter size:	2 [bytes]

5. Automatic control - dimming step size

This parameter defines the percentage value of dimming step during the automatic control.

Available settings:	1-99 - dimming step percentage value		
Default setting:	1	Parameter size:	1 [byte]

6. Automatic control - time of a dimming step

This parameter defines the time of single dimming step set in parameter 5 during the automatic control.

Available settings:	0-255 (0-2.55s, in 10ms steps)		
Default setting:	1 (10ms)	Parameter size:	2 [bytes]

7. Manual control - dimming step size

This parameter defines the percentage value of dimming step during the manual control.

Available settings:	1-99 - dimming step percentage value		
Default setting:	1	Parameter size:	1 [byte]

8. Manual control - time of a dimming step

This parameter defines the time of single dimming step set in parameter 7 during the manual control.

Available settings:	0-255 (0-2.55s, in 10ms steps)		
Default setting:	5 (50ms)	Parameter size:	2 [bytes]

9. State of the device after a power failure

The Dimmer 2 will return to the last state before power failure.

Available settings:	0 - the Dimmer 2 does not save the state before a power failure, it returns to „off“ position 1 - the Dimmer 2 restores its state before power failure		
Default setting:	1	Parameter size:	1 [byte]

10. Timer functionality (auto - off)

This parameter allows to automatically switch off the device after specified time from switching on the light source. It may be useful when the Dimmer 2 is installed in the stairway.

Available settings:	0 - Function disabled 1-32767 - time to turn off measured in seconds (1s-9.1h)		
Default setting:	0	Parameter size:	2 [bytes]

i NOTE

Automatic control is performed through:

- single push-button click
- double push-button click
- Z-Wave control frames

i NOTE

Manual control is performed through holding the push-button.

11. ALL ON/ALL OFF function

Parameter allows for activation/deactivation of Z-Wave commands enabling/disabling all devices located in direct range of the main controller.

Available settings:	0 - ALL ON not active, ALL OFF not active 1 - ALL ON not active, ALL OFF active 2 - ALL ON active, ALL OFF not active 255 - ALL ON active, ALL OFF active		
Default setting:	255	Parameter size:	2 [bytes]

13. Force auto-calibration

Changing value of this parameter will force the calibration process. During the calibration parameter is set to 1 or 2 and switched to 0 upon completion.

Available settings:	0 - readout 1 - force auto-calibration of the load without FIBARO Bypass 2 2 - force auto-calibration of the load with FIBARO Bypass 2		
Default setting:	0	Parameter size:	1 [byte]

14. Auto-calibration status (read-only parameter)

This parameter determines operating mode of the Dimmer 2 (automatic/manual settings).

Available settings:	0 - calibration procedure not performed or Dimmer 2 operates on manual settings 1 - Dimmer 2 operates on auto-calibration settings		
Default setting:	0	Parameter size:	1 [byte]

15. Burnt out bulb detection

Function based on the sudden power variation of a specific value, interpreted as a LOAD ERROR.

Available settings:	0 - function disabled 1-99 - percentage value of power variation, compared to standard power consumption, measured during the calibration procedure (to be interpreted as load error/burnt out bulb)		
Default setting:	30	Parameter size:	1 [byte]

16. Time delay of a burnt out bulb (parameter 15) or overload (parameter 39) detection

Time of delay (in seconds) for power variation detection, interpreted as a LOAD ERROR or OVERLOAD detection (too much power connected to the Dimmer 2).

CAUTION

Parameter 15 is relevant only when parameter 58 is set to 0 and the control mode is consistent with the mode set during the calibration process (parameter 30).

Available settings:	0 - detection of a burnt out bulb disabled 1-255 - delay time in seconds		
Default setting:	5	Parameter size:	2 [bytes]

19. Forced switch on brightness level

If the parameter is active, switching on the Dimmer 2 (S1 single click) will always set this brightness level.

Available settings:	0 - function disabled 1-99 - percentage level of brightness		
Default setting:	0	Parameter size:	1 [byte]

GROUP 20 - Dimmer 2 operation - Switches

20. Switch type

Choose between momentary, toggle and roller blind switch.

Available settings:	0 - momentary switch 1 - toggle switch 2 - roller blind switch - two switches operate the Dimmer 2 (S1 to brighten, S2 to dim)		
Default setting:	0	Parameter size:	1 [byte]

21. The value sent to associated devices on single click

This parameter defines the value sent to devices associated with Dimmer 2 after its enabling.

Available settings:	0 - 0xFF value is sent, which will set associated devices to their last saved state 1 - current Dimmer 2 state is sent, which will synchronize brightness level of associated devices (other dimmers for example)		
Default setting:	0	Parameter size:	1 [byte]

22. Assign toggle switch status to the device status

By default each change of toggle switch position results in action of Dimmer 2 (switch on/off) regardless the physical connection of contacts.

Available settings:	0 - device changes status on switch status change 1 - device status is synchronized with switch status		
Default setting:	0	Parameter size:	1 [byte]

i NOTE

Parameter 24 values may be combined, e.g. 1+2=3 means that associations on switching ON or OFF the Dimmer 2 (single click) will not be sent.

i NOTE

Parameter 25 values may be combined, e.g. 1+2=3 means that associations on switching ON or OFF the Dimmer 2 (single click) will not be sent.

23. Double click option - set the brightness level to MAX

Available settings:	0 - double click disabled 1 - double click enabled		
Default setting:	1	Parameter size:	1 [byte]

24. Command frames sent in 2nd and 3rd association groups (S1 associations)

Parameter determines, which actions will **not** result in sending frames to association groups.

Available settings:	0 - all actions send to association groups 1 - do not send when switching ON (single click) 2 - do not send when switching OFF (single click) 4 - do not send when changing dimming level (holding and releasing) 8 - do not send on double click 16 - send 0xFF value on double click		
Default setting:	0	Parameter size:	1 [byte]

25. Command frames sent in 4th and 5th association groups (S2 associations)

Parameter determines, which actions will **not** result in sending frames to association groups.

Available settings:	0 - all actions send to association groups 1 - do not send when switching ON (single click) 2 - do not send when switching OFF (single click) 4 - do not send when changing dimming level (holding and releasing) 8 - do not send on double click 16 - send 0xFF value on double click		
Default setting:	0	Parameter size:	1 [byte]

26. The function of 3-way switch

Switch no. 2 controls the Dimmer 2 additionally (in 3-way switch mode). Function disabled for parameter 20 set to 2 (roller blind switch).

Available settings:	0 - 3-way switch function for S2 disabled 1 - 3-way switch function for S2 enabled		
Default setting:	0	Parameter size:	1 [byte]

27. Associations in Z-Wave network security mode

This parameter defines how commands are sent in specified association groups: as secure or non-secure. Parameter is active only in Z-Wave network security mode. It does not apply to 1st Lifeline group.

Available settings:	0 - all groups (II-V) sent as non-secure 1 - 2nd group sent as secure 2 - 3rd group sent as secure 4 - 4th group sent as secure 8 - 5th group sent as secure 15 - all groups (II-V) sent as secure		
Default setting:	15	Parameter size:	1 [byte]

28. Scene activation functionality

SCENE ID depends on the switch type configurations.

Available settings:	0 - functionality deactivated 1 - functionality activated		
Default setting:	0	Parameter size:	1 [byte]

SCENE ID value sent at specified configuration:

Momentary switches	
SCENE ID: S1 input	SCENE ID: S2 input
16 : 1 x click	26 : 1 x click
14 : 2 x click	24 : 2 x click
- : 3 x click	25 : 3 x click
12 : hold	22 : hold
13 : release	23 : release
Toggle switches	
SCENE ID: S1 input	SCENE ID: S2 input
10 : OFF to ON	20 : OFF to ON
11 : ON to OFF	21 : ON to OFF
14 : 2 x click	24 : 2 x click
- : 3 x click	25 : 3 x click
Roller blinds switches	
SCENE ID: S1 input	SCENE ID: S2 input
10 : turn ON (1 x click)	11 : turn OFF (1 x click)
13 : release	13 : release
14 : 2 x click	14 : 2 x click
- : 3 x click	15 : 3 x click
17 : brightening	18 : dimming

29. Switch functionality of S1 and S2

This parameter allows for switching the role of keys connected to S1 and S2 without changes in connection.

Available settings:	0 - standard mode 1 - S1 operates as S2, S2 operates as S1		
Default setting:	0	Parameter size:	1 [byte]

i NOTE

Parameter 27 values may be combined, e.g. 1+2=3 means that 2nd & 3rd group are sent as secure.

i NOTE

Enabling scene activation functionality may cause slight delay in response to external switches and sending associations.

CAUTION

Modifications of parameters in GROUP 30 should be performed only by a qualified installer.

GROUP 30 - Dimmer 2 operation - Advanced functionality

30. Load control mode

This parameter allows to set the desired load control mode. The device automatically adjusts correct control mode, but the installer may force its change using this parameter.

Forced auto-calibration will set this parameter's value to 2.

Available settings:	0 - forced leading edge control 1 - forced trailing edge control 2 - control mode selected automatically (based on auto-calibration)		
Default setting:	2	Parameter size:	1 [byte]

31. Load control mode recognized during auto-calibration (read only)

Available settings:	0 - leading edge 1 - trailing edge		
Default setting:	—	Parameter size:	1 [byte]

32. On/Off mode

This mode is necessary while connecting non-dimmable light sources. Setting this parameter to 1 automatically ignores brightening/dimming time settings. Forced auto-calibration will set this parameter's value to 2.

Available settings:	0 - on/off mode disabled (dimming is possible) 1 - on/off mode enabled (dimming is not possible) 2 - mode selected automatically		
Default setting:	2	Parameter size:	1 [byte]

33. Dimmability of the load (read only)

This parameter contains an information about possibility of dimming the load detected during calibration procedure.

Available settings:	0 - Load recognized as dimmable 1 - Load recognized as non-dimmable		
Default setting:	—	Parameter size:	1 [byte]

34. Soft-Start functionality

Time required to warm up the filament of halogen bulb.

Available settings:	0 - no soft-start 1 - short soft-start (0.1s) 2 - long soft-start (0.5s)		
Default setting:	1	Parameter size:	1 [byte]

35. Auto-calibration after power on

This parameter determines the trigger of auto-calibration procedure, e.g. power on, load error, etc.

Available settings:	0 - No auto-calibration of the load after power on 1 - Auto-calibration performed after first power on 2 - Auto-calibration performed after each power on 3 - Auto-calibration performed after first power on or after each LOAD ERROR alarm (no load, load failure, burnt out bulb), if parameter 37 is set to 1 also after alarms: SURGE (Dimmer 2 output overvoltage) and OVERCURRENT (Dimmer 2 output overcurrent) 4 - Auto-calibration performed after each power on or after each LOAD ERROR alarm (no load, load failure, burnt out bulb), if parameter 37 is set to 1 also after alarms: SURGE (Dimmer 2 output overvoltage) and OVERCURRENT (Dimmer 2 output overcurrent)		
Default setting:	1	Parameter size:	1 [byte]

37. Behaviour of the Dimmer 2 after OVERCURRENT or SURGE

Occuring of errors related to surge or overcurrent results in turning off the output to prevent possible malfunction. By default the device performs three attempts to turn on the load (useful in case of momentary, short failures of the power supply).

Available settings:	0 - device permanently disabled until re-enabling by command or external switch 1 - three attempts to turn on the load		
Default setting:	1	Parameter size:	1 [byte]

38. Brightness level correction for flickering loads

Correction reduces spontaneous flickering of some capacitive load (e.g. dimmable LEDs) at certain brightness levels in 2-wire installation.

In countries using ripple-control, correction may cause changes in brightness. In this case it is necessary to disable correction or adjust time of correction for flickering loads.

Available settings:	0 - automatic correction disabled 1-254 - duration of correction in seconds 255 - automatic correction always enabled		
Default setting:	255	Parameter size:	2 [bytes]

i NOTE

Parameter 39 is relevant only when parameter 58 is set to 0.

39. Power limit - OVERLOAD

Reaching the defined value will result in turning off the load. Additional apparent power limit of 350VA is active by default.

Available settings:	0 - functionality disabled 1-350 - 1-350W		
Default setting:	250	Parameter size:	2 [bytes]

GROUP 40 - Dimmer 2 operation - Alarms**40. Response to General Purpose Alarm**

Available settings:	0 - No reaction 1 - Turn on the load 2 - Turn off the load 3 - Load blinking		
Default setting:	3	Parameter size:	1 [byte]

41. Response to Water Flooding Alarm

Available settings:	0 - No reaction 1 - Turn on the load 2 - Turn off the load 3 - Load blinking		
Default setting:	2	Parameter size:	1 [byte]

42. Response to Smoke, CO or CO2 Alarm

Available settings:	0 - No reaction 1 - Turn on the load 2 - Turn off the load 3 - Load blinking		
Default setting:	3	Parameter size:	1 [byte]

43. Response to Temperature Alarm

Available settings:	0 - No reaction 1 - Turn on the load 2 - Turn off the load 3 - Load blinking		
Default setting:	1	Parameter size:	1 [byte]

44. Time of alarm state

Available settings:	1-32767 (1-32767 seconds)		
Default setting:	600 (600s)	Parameter size:	2 [bytes]

i NOTE

Alarm state may be cancelled earlier, as a result of pressing the switch or sending the Z-Wave command frame.

Alarm settings - reports

45. OVERLOAD alarm report (load power consumption too high)

Available settings:	0 - No reaction 1 - Send an alarm frame		
Default setting:	1	Parameter size:	1 [byte]

46. LOAD ERROR alarm report (no load, load failure, burnt out bulb)

Available settings:	0 - No reaction 1 - Send an alarm frame		
Default setting:	1	Parameter size:	1 [byte]

47. OVERCURRENT alarm report (short circuit, burnt out bulb causing overcurrent)

Available settings:	0 - No reaction 1 - Send an alarm frame		
Default setting:	1	Parameter size:	1 [byte]

48. SURGE alarm report (Dimmer 2 output overvoltage)

Available settings:	0 - No reaction 1 - Send an alarm frame		
Default setting:	1	Parameter size:	1 [byte]

49. OVERHEAT (critical temperature) and VOLTAGE DROP (low voltage) alarm report

Available settings:	0 - No reaction 1 - Send an alarm frame		
Default setting:	1	Parameter size:	1 [byte]

GROUP 50 - Active power and energy reports

50. Active power reports

The parameter defines the power level change that will result in a new power report being sent. The value is a percentage of the previous report.

Available settings:	0 - power reports disabled 1-100 (1-100%) - power report threshold		
Default setting:	10 (10%)	Parameter size:	1 [byte]

52. Periodic active power and energy reports

Parameter 52 defines a time period between consecutive reports. Timer is reset and counted from zero after each report.

Available settings:	0 - periodic reports disabled 1-32767 (1-32767 seconds)		
Default setting:	3600 (3600s)	Parameter size:	2 [bytes]

53. Energy reports

Energy level change which will result in sending a new energy report.

Available settings:	0 - energy reports disabled 1-255 (0.01-2.55 kWh) - report triggering threshold		
Default setting:	10 (0.1 kWh)	Parameter size:	2 [bytes]

54. Self-measurement

The Dimmer 2 may include active power and energy consumed by itself in reports sent to the main controller.

Available settings:	0 - Self-measurement inactive 1 - Self-measurement active		
Default setting:	0	Parameter size:	1 [byte]

i NOTE

Parameter 58 is set to 0 after forced auto-calibration.

58. Method of calculating the active power

This parameter defines how to calculate active power. It is useful in a case of 2-wire connection with light sources other than resistive.

Available settings:	0 - measurement based on the standard algorithm 1 - approximation based on the calibration data 2 - approximation based on the control angle		
Default setting:	0	Parameter size:	1 [byte]

i NOTE

Parameter 59 works only when parameter 58 has a value other than 0.

59. Approximated power at the maximum brightness level

This parameter determines the approximate value of the power that will be reported by the device at its maximum brightness level.

Available settings:	0-500 (0-500W) - power consumed by the load at the maximum brightness level.		
Default setting:	0	Parameter size:	2 [bytes]

#14: Specifications

Power supply:	100-240V~ 50/60Hz
Power consumption:	< 1.3W
Operational temperature:	0-35°C
For installation in boxes:	Ø ≥ 50mm
Operational current:	0.25-1.1A
Device temperature protection:	105°C
Active element:	semiconductor electronic switch ε
Device control:	remotely - radio waves directly - external switch
Radio protocol:	Z-Wave (500 series chip)
Radio signal power:	up to 1mW
Radio frequency:	868.4 or 869.8 MHz EU; 908.4, 908.42 or 916.0 MHz US; 921.4 or 919.8 MHz ANZ; 869.0 MHz RU; 920.9, 921.7 or 923.1 MHz TW;
Range:	up to 50 m outdoors up to 40 m indoors (depending on building materials)
Comply with EU directives:	RoHS 2011/65/EU RED 2014/53/EU
Dimensions (L x W x H):	42.5 x 38.25 x 20.3 mm

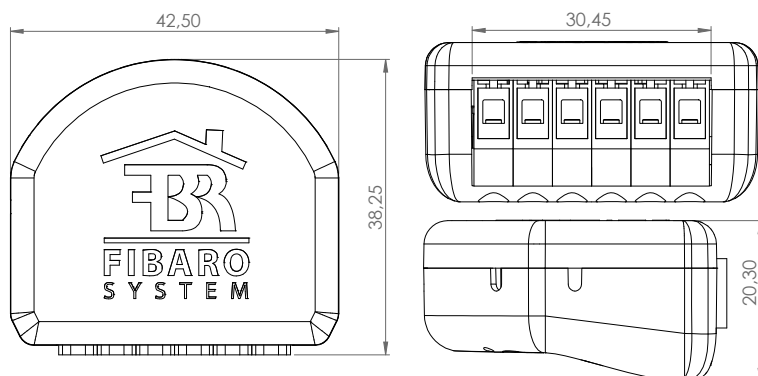

i NOTE

Occasional **flickering** of the lighting may be the result of ripple-control signals from the electricity supplier.

The occurrence and magnitude of this effect depends on the country, region and time of the day.

The effect is more frequent in 2-wire installation, on low dimming levels and with LED light sources.

Voltage drops, dips and harmonics may also cause flickering.

i NOTE

Radio frequency of individual device must be same as your Z-Wave controller. Check information on the box or consult your dealer if you are not sure.

#15: Regulations

This device complies with Part 15 of the FCC Rules

Operation is subject to the following two conditions:

1. This device may not cause harmful interference
2. This device must accept any interference received, including interference that may cause undesired operation. This equipment has been tested and found to comply with the limits for a Class B digital device, pursuant to part 15 of the FCC Rules. These limits are designed to provide reasonable protection against harmful interference in a residential installation. This equipment generates, uses and can radiate radio frequency energy and, if not installed and used in accordance with the instructions, may cause harmful interference to radio communications. However, there is no guarantee that interference will not occur in a particular installation. If this equipment does cause harmful interference to radio or television reception, which can be determined by turning the equipment off and on, the user is encouraged to try to correct the interference by one or more of the following measures:
 - Reorient or relocate the receiving antenna.
 - Increase the separation between the equipment and receiver.
 - Connect the equipment into an outlet on a circuit different from that to which the receiver is connected.
 - Consult the dealer or an experienced radio/TV technician for help.

Changes and modifications not expressly approved by the manufacturer or registrant of this equipment can void your authority to operate this equipment under Federal Communications Commission's rules.

Industry Canada (IC) Compliance Notice

This device complies with Industry Canada license-exempt RSSs. Operation is subject to the following two conditions: (1) this device may not cause interference, and (2) this device must accept any interference, including interference that may cause undesired operation of the device.

Cet appareil est conforme aux normes d'exemption de licence RSS d'Industry Canada. Son fonctionnement est soumis aux deux conditions suivantes : (1) cet appareil ne doit pas causer d'interférence et (2) cet appareil doit accepter toute interférence, notamment les interférences qui peuvent affecter son fonctionnement.

Legal Notices

All information, including, but not limited to, information regarding the features, functionality, and/or other product specification are subject to change without notice. Fibaro reserves all rights to revise or update its products, software, or documentation without any obligation to notify any individual or entity.

FIBARO and Fibar Group logo are trademarks of Fibar Group S.A. All other brands and product names referred to herein are trademarks of their respective holders.

DGT Warning Statement

Article 12

Without permission, any company, firm or user shall not alter the frequency, increase the power, or change the characteristics and functions of the original design of the certified lower power frequency electric machinery.

Article 14

The application of low power frequency electric machineries shall not affect the navigation safety nor interfere a legal communication, if an interference is found, the service will be suspended until improvement is made and the interference no longer exists.

第十二條

經型式認證合格之低功率射頻電機，非經許可，公司、商號或使用者均不得擅自變更頻率、加大功率或變更原設計之特性及功能。

第十四條

低功率射頻電機之使用不得影響飛航安全及干擾合法通信；經發現有干擾現象時，應立即停用，並改善至無干擾時方得繼續使用。

前項合法通信，指依電信法規定作業之無線電通信。

低功率射頻電機須忍受合法通信或工業、科學及醫療用電波輻射性電機設備之干擾。

Declaration of conformity

Hereby, Fibar Group S.A. declares that the device is in compliance with the essential requirements and other relevant provisions of Directive 2014/53/EU. The full text of the EU declaration of conformity is available at the following internet address: www.manuals.fibaro.com

WEEE Directive Compliance

Device labelled with this symbol should not be disposed with other household wastes. It shall be handed over to the applicable collection point for the recycling of waste electrical and electronic equipment.

