

CONTROL PANEL FOR 400V GEARMOTORS

Z SERIES

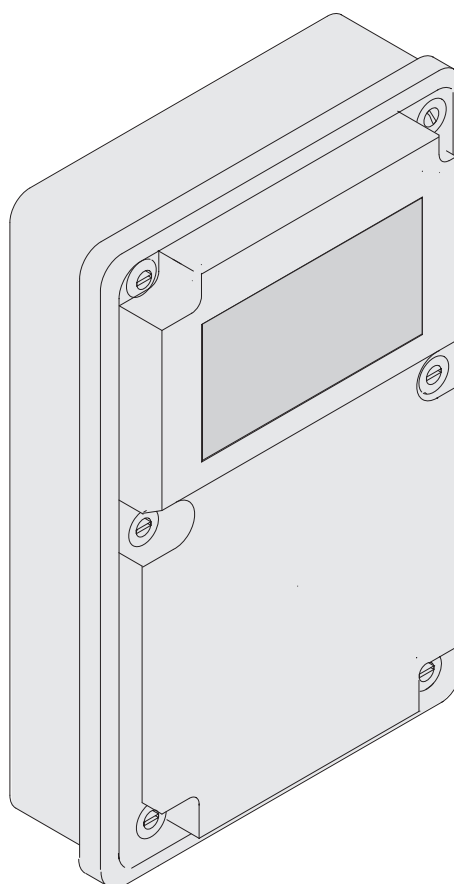

INSTALLATION MANUAL

ZA2S



"IMPORTANT SAFETY INSTRUCTIONS FOR INSTALLATION"

"CAUTION: IMPROPER INSTALLATION MAY CAUSE SERIOUS DAMAGE, FOLLOW ALL INSTALLATION INSTRUCTIONS CAREFULLY"

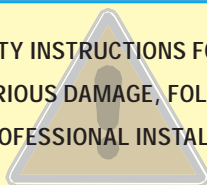
"THIS MANUAL IS ONLY FOR PROFESSIONAL INSTALLERS OR QUALIFIED PERSONS"



1 Legend

-  This symbol indicates sections to be read with particular care.
-  This symbol indicates sections concerning safety.
-  This symbol indicates notes to communicate to users.

2 Destination and limits of use

2.1 Intended use

The ZA2S control panel has been engineered to control the SUPERFROG automations, to operate swing doors.

 The use of this product for purposes other than as described above and installation executed in a manner other than as instructed in this technical manual are prohibited.

2.2 Limits to use

- Make sure the distances and cable diameters are as shown in the table at chapter 5.4.
- The overall power of the motors must not exceed 1200W.

3 Reference standards

This product complies with the following standards: EN 12978, UNI EN 954-1, CEI EN 60335-1, UNI EN 12453.

4 Description

The control panel is powered by 230/400V a.c. triphase through the R-S-T-N terminals, with 50/60Hz frequency.

The command devices and accessories run on 24V. Moreover, the total accessories cannot run on more than 40W.

A 12V electric-lock can be connected to the system.

The control panel automatically controls the following functions:

- 1) automatic closing (adjustable);
- 2) working cycle (adjustable);
- 3) open-close or only opening command;
- 4) Reopening during the closing phase, re-closing during the opening phase or partial stop;
- 5) Maintained action (on the card, cut the spot marked with the  symbol);
- 6) pre-flashing upon opening and closing;
- 7) obstruction detection when motor is not running;
- 8) Delaying the opening of the 1st gate leaf and during closing of the 2nd leaf (the latter is adjustable).

FUZE	
Protection	Fuse type
Low-tension	2A

4.1 Technical specifications

Power Supply: 230/400V A.C. 50/60Hz tri-phase

Power draw when idle: 100mA

Max Power for accessories 12V: 15W

Max Power for accessories 24V: 30W

Max Power for accessories 230V: 30W

Protection level: IP54

Weight: 6.2 kg

Insulation class: 

Material: ABS



The data and information reported in this installation manual are susceptible to change at any time and without obligation on CAME cancelli automatici s.p.a. to notify users.

4.2 Dimensions, distance between centres and fixing holes

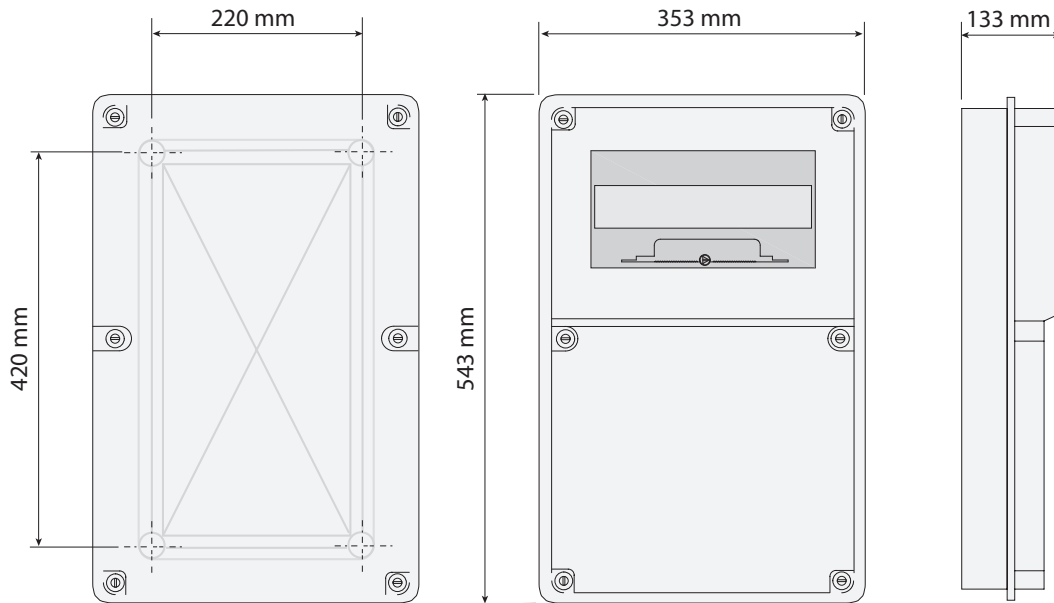

4.3 Main components

- 1) Main switch
- 2) Cut-off switch
- 3) Power meter
- 4) Safety switch for 1st motor
- 5) Safety switch for 2nd motor
- 6) 400-24V Transformer
- 7) Terminal for connecting to power source
- 8) Terminal for connecting gearmotors and flashing lamp.
- 9) Opening remote control switch for 1st motor
- 10) Closing remote control switch for 1st motor
- 11) Opening remote control switch for 2nd motor
- 12) Closing remote control switch for 2nd motor
- 13) Low voltage fuse
- 14) TR2M Trimmer: to adjust the delayed closing of the 2nd motor
- 15) TL Trimmer: to adjust the working time
- 16) TCA Trimmer: to adjust the automatic closing
- 17) Function selector
- 18) Terminal to connect accessories and command devices

⚠ Warning! Before doing any work on the automation kit, cut off the power supply and disconnect the emergency batteries (if connected).

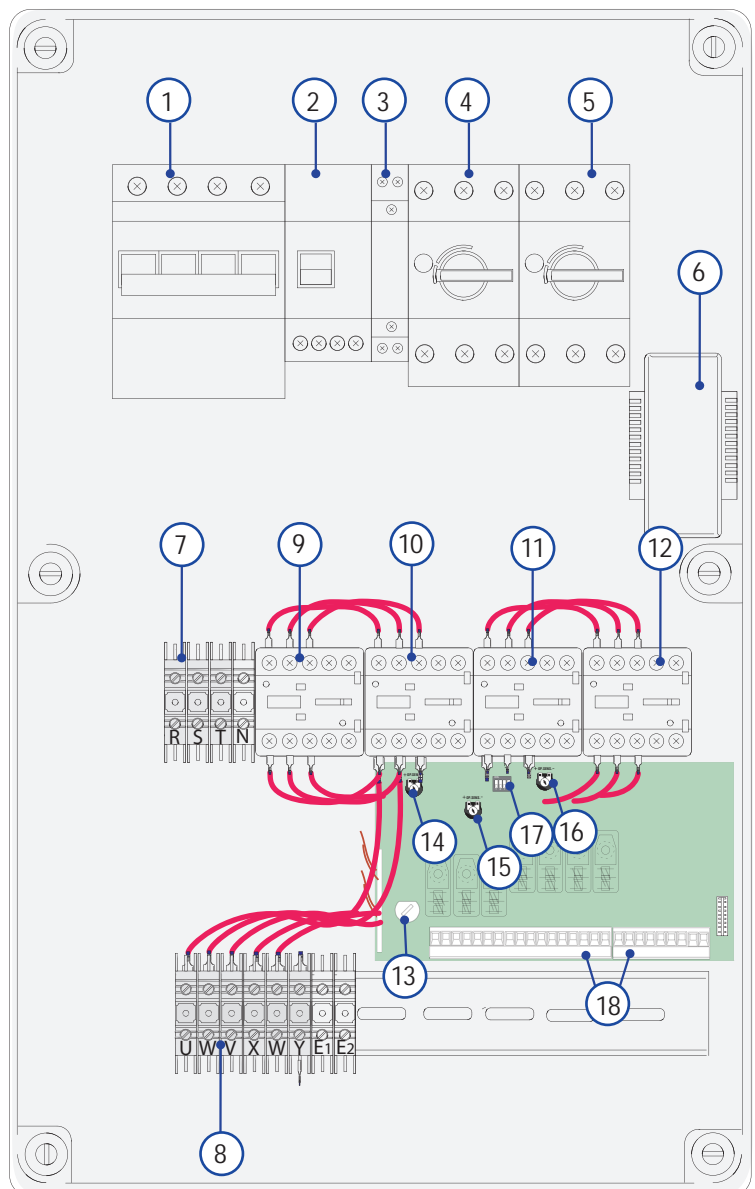

5 Installation

5.1 Preliminary checks

⚠ Before proceeding with the installation, it is necessary to:

- Make sure that the control panel is attached in a protected and impact-free area, that the surface it is attached is solid, and that it is attached to the surface with proper tools (screws, anchor lugs, and so on);
- Provide for a suitable omnipolar disconnection device with contacts more than 3 mm apart, and independent (sectioned off) power supply;
- ⊕ Make sure that any connections inside the container (made for the continuity of the protection system) are provided with additional insulation compared to the other conductive parts inside;
- Make sure that any connections inside the case (that provide continuance to the protective circuit) be fitted with extra insulation as compared to the other conductive parts inside.

5.2 Tools and materials

Make sure all tools and materials necessary are within reach to install the edge in total safety, and in compliance with the regulations in force. The following figure illustrates the minimum equipment needed by the installer.

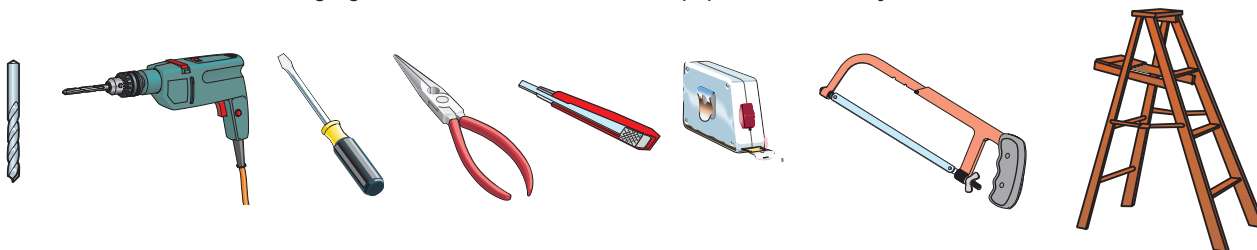

5.3 Attaching the control panel

Attach the base of the control panel in a protected area, we suggest using round head screws with 6 mm diameter with a Phillips drive head.

Puncture the pre-drilled holes and insert the cable glands with conduits for the electric wires.

Note: the predrilled holes have different diameters, these being 23, 28 and 37 mm.

After making the necessary adjustments, fix the cover using the screws supplied.

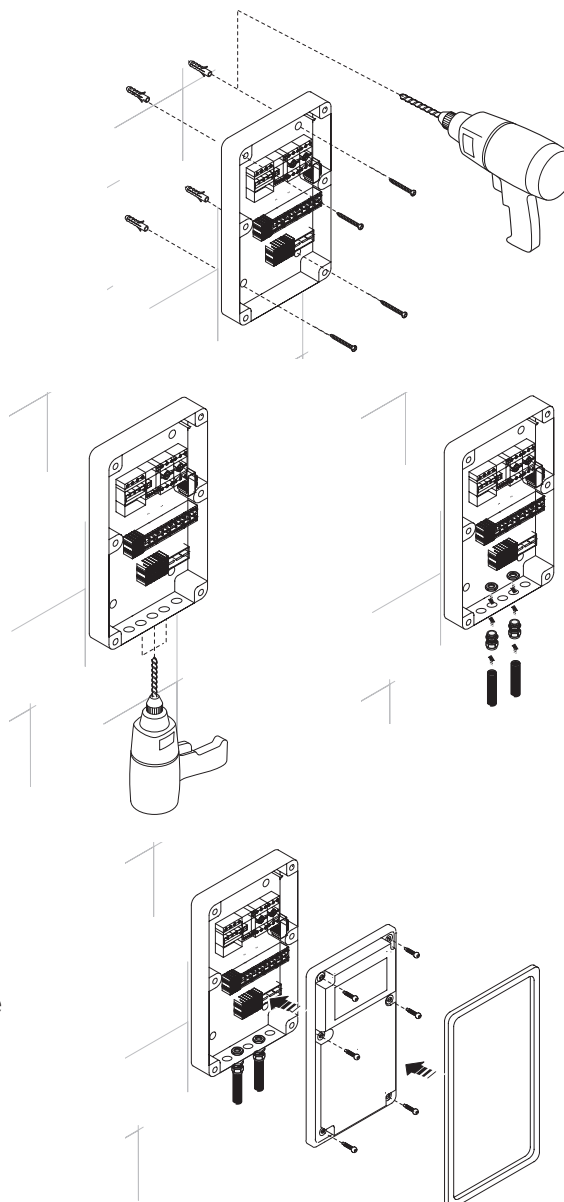

5.4 Cable list and minimum thickness

Connections	Type of cable	Length of cable 1 < 10 m	L. of cable 10 < 20 m	L. of cable 20 < 30 m
230/400V 3F power supply	FROR CEI 20-22 CEI EN 50267-2-1	4G x 1,5 mm ²	4G x 2,5 mm ²	4G x 4 mm ²
230/400V 3F motor power supply		4G x 1 mm ²	4G x 1,5 mm ²	4G x 2,5 mm ²
Flashing lamp		2 x 0,5 mm ²	2 x 1 mm ²	2 x 1,5 mm ²
Photocell transmitters		2 x 0,5 mm ²	2 x 0,5 mm ²	2 x 0,5 mm ²
Photocell receivers		4 x 0,5 mm ²	4 x 0,5 mm ²	4 x 0,5 mm ²
power supply to accessories		2 x 0,5 mm ²	2 x 0,5 mm ²	2 x 1 mm ²
Control and safety devices		2 x 0,5 mm ²	2 x 0,5 mm ²	2 x 0,5 mm ²
Antenna connection	RG58	max. 10 m		

N.B.: if the cable length differs from that specified in the table, then you must determine the proper cable diameter in the basis of the actual power draw by the connected devices and depending on the standards specified in CEI EN 60204-1.

For connections that require several, sequential loads, the sizes given on the table must be re-evaluated based on actual power draw and distances.

When connecting products other than those mentioned in this manual please see the documents provided with the products themselves.

5.5 Electrical connections

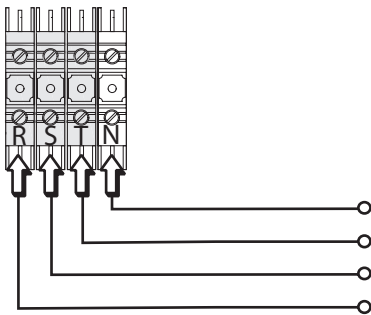

Power Supply 230/400V A.C. 50/60Hz tri-phase

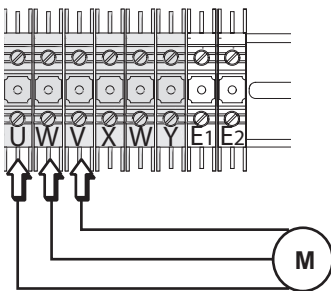

Connection for the **delayed opening** 230/400V A.C. 50/60Hz tri-phase gearmotor

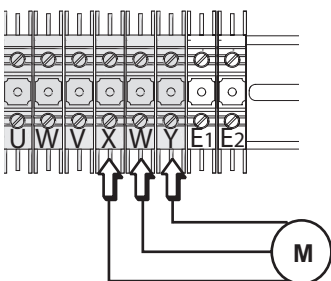

Connection for the **delayed closing** 230/400V A.C. 50/60Hz tri-phase gearmotor

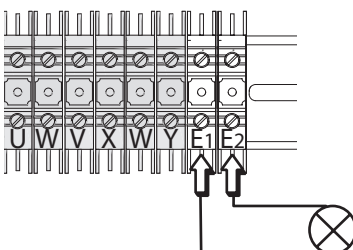

Movement Flasher (contact capacity: 230V – 25W max.)
Flashes during the opening and closing phases.

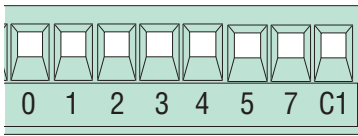

24V A.C. output for powering accessories 30W max.

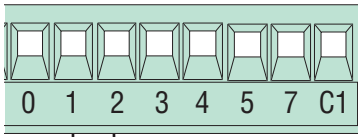

Stop button (N.C. contact) - Stops movement, excludes the automatic closing functions. To restart the automated kit, press a command button or a remote control button.

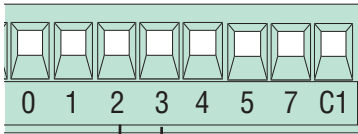

Opening Button (N.O. contact) - Gate opening button

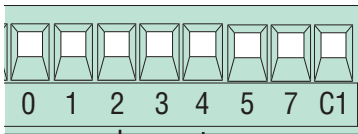

Closing button (N.O. contact) - Gate closing button

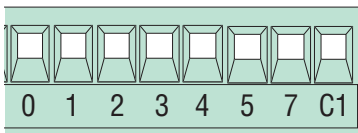

24V - 3W max. *Flashing lamp.* - Lamp signalling that gate is open.

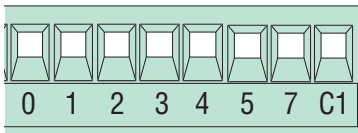

Push button controlled (N.O. contact) - Opening and closing devices. Command modes: open-close

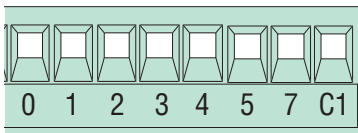

Key selector (N.O. contact) - Opening and closing devices. Command modes: open-close

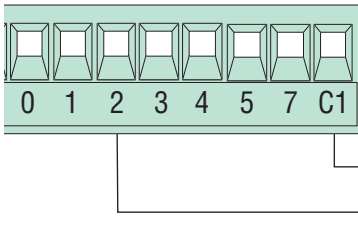

(N.C. Contact for "re-opening during closing" - Input for photocells, sensitive profiles and other devices complying with EN 12978 standards. During the closing phase, operating the device will invert the motion until complete opening is achieved. If this contact is not used, bridge the terminals amongst themselves.

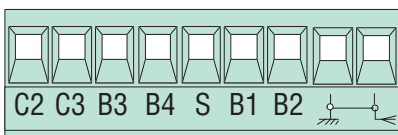
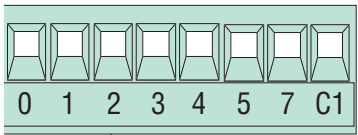

(N.C.) Contact for "re-closing during opening" - Input for photocells, sensitive edges and other devices compliant with EN 12978 standards. During opening, operation of the device causes inversion of direction until complete closure is obtained. If this contact is not used, bridge the terminals amongst themselves.

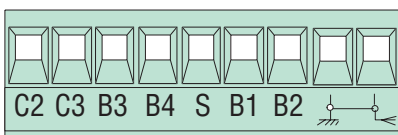
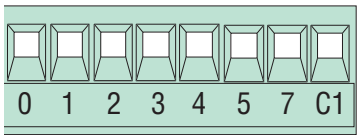

(N.C.) Contact for "partial stop" - Input for photocells, sensitive edges and other devices complying with the EN 12978 standard. Stops the gate leaf if it is moving and, if set up, automatically closes the gate. If this contact is not used bridge the terminals amongst themselves.

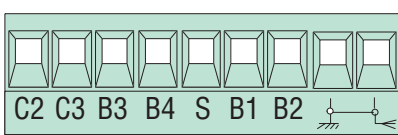
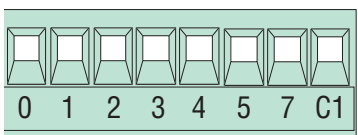

Connection for the 12V electric-lock - 15W max.

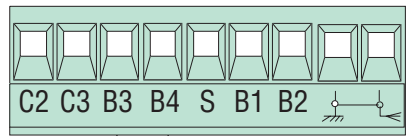

(N.O.) contact output - the contact shuts off for 3" with each opening-impulse. Contact rate: 2A - 230V A.C.

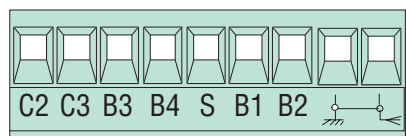

(N.O.) Contact output with two-channel receiver Contact rate (with resistive load): 1A - 24V D.C.

5.6 Function selection

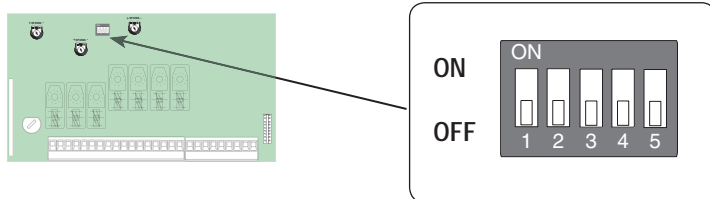

- 1 ON - **Pre-flashing upon opening and closing** – Following an opening or closing command, the flashing light connected on E1-E2, flashes for 5 seconds before the cycle begins.
- 2 ON - **Automatic closing** – the timer for the automatic closing is activated when the door completes its opening cycle. The set time is adjustable, and it is any how conditioned by the possible intervention of the safety devices and dies not activate after a total safety 'stop' or during a power outage.
N.B.: If «maintained action» mode is selected, check that the automatic closure function is deactivated (2 OFF).
- 3 ON - **Detection of obstacle** – When motor is not running (gate closed, open or after a total stop command), prevents any movement if the safety devices (e.g. the photocells) detect an obstacle
- 4ON / 5OFF - **open only**' function with radio transmitter (with radio frequency card inserted).
- 5ON/ 4OFF - **'open-close-inversion'** function with button (2-7) and radio transmitter (with radio frequency card inserted).

5.7 Adjustments

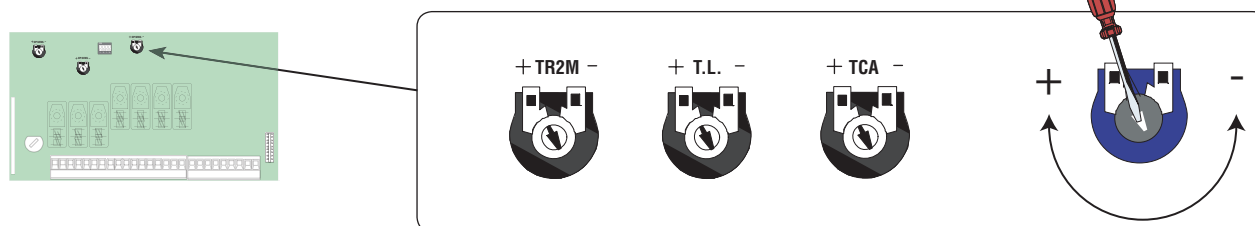

Trimmer TL. = regulates the motor working time, for each single opening or closing, it has a range of 2 to 60 seconds

Trimmer T.C.A. = Adjusts the waiting time in the opening position. Once this time frame has lapsed, an automatic closing procedure is performed. The waiting time may be adjusted to between 3 second and 60 seconds. Adjusting to the minimum excludes the automatic closing function.

Trimmer T.R.2M. = Adjusts the waiting time closure delay for 2nd motor (3 to 10 seconds)

6 Demolition and disposal



We use different materials to manufacture our products. Most of them (aluminium, plastic, iron, electric cables) is disposable urban waste. They may be recycled through special collection and disposal at licensed centres.



Other components (electronic cards, batteries for the remote controls, etc.) may contain polluting materials. They must therefore be removed and given to licensed companies that specialise in collecting and disposing of such materials.

7 Manufacturer's warranty



MANUFACTURER'S DECLARATION OF CONFORMITY

Pursuant to annex II B of the Machinery Directive 98/37/EC



CAME Cancelli Automatici S.p.A.
via Martiri della Libertà, 15
31030 Dosson di Casier - Treviso - ITALY
tel (+39) 0422 4940 - fax (+39) 0422 4941
internet: www.came.it - e-mail: info@came.it

IMPORTANT WARNING!

**Do not use the equipment specified here above, before completing the full installation
In full compliance with the Machinery Directive 98/37/EC**

Declares under its own responsibility that the equipments for automatic garage doors and gates listed below:

CONTROL PANEL FOR ZA2S SWING GATES

... comply with the National Law related to the following European Directives and to the applicable parts of the following Standards.

98/37/CE - 98/79/CE	MACHINERY DIRECTIVE
98/336/CEE - 92/31/CEE	ELECTROMAGNETIC COMPATIBILITY DIRECTIVE
73/23/CEE - 93/68/CE	LOW VOLTAGE DIRECTIVE
89/106/CEE	CONSTRUCTION PRODUCTS DIRECTIVE

EN 13241-1	EN 12635	EN 61000-6-2
EN 12453	EN 12978	EN 61000-6-3
EN 12445	EN 60335-1	EN 60204-1

Reference code to request a true copy of the original: **DDFB EN A003 ver.1.0**

CAME UNITED KINGDOM LTD
UNIT 3, ORCHARD BUSINESS PARK TOWN
STREET, SANDIACRE
NOTTINGHAM - NG10 5BP - U.K.
Tel 0044 115 9210430
Fax 0044 115 9210431

