



**SEA**<sup>®</sup>  
Sistemi Elettronici  
di Apertura Porte e Cancelli  
International registered trademark n. 804888

**CE**  
**Italiano**  
**English**  
**Français**  
**Español**

# **SWING 2 DG R2F**

(Cod. 23021096 - 23021110 - 33001165/75/80)

**CENTRALE ELETTRONICA PER 1 O 2 MOTORI A 230V/115V**  
**ELECTRONIC CONTROL UNIT FOR 1 OR 2 230V/115V MOTORS**  
**ARMOIRE DE COMMANDE POUR 1 OU 2 MOTEURS EN 230V/115V**  
**CENTRAL ELECTRÓNICA PARA 1 O 2 MOTORES A 230V/115V**

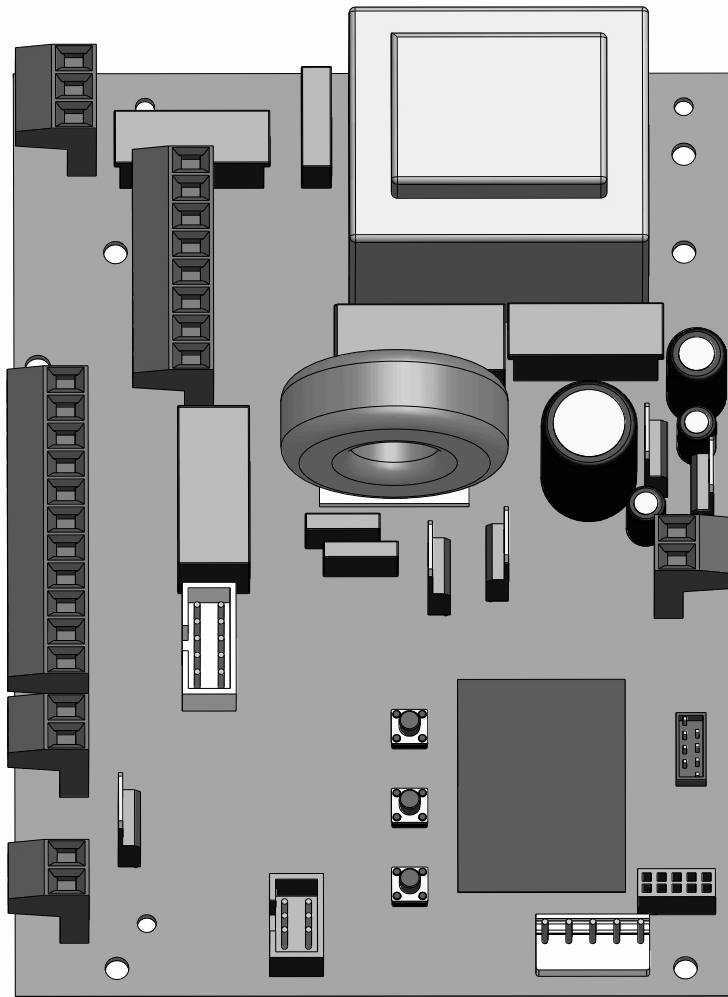

**SEA S.p.A.**  
**Zona industriale 64020 S.ATTO Teramo - (ITALY)**  
**Tel. +39 0861 588341 r.a. Fax +39 0861 588344**

**[www.seateam.com](http://www.seateam.com)**

**[seacom@seateam.com](mailto:seacom@seateam.com)**

# COMPONENTS

## TECHNICAL SPECIFICATIONS

Control unit power supply: 230 Vac 50/60 Hz - 115Vac 50/60 Hz

Absorption in stand by: 30 mA

Environment temperature : -20°C ↕ +50°C ↕

Specifications of external enclosure: 183 X 238 X 120 - Ip55

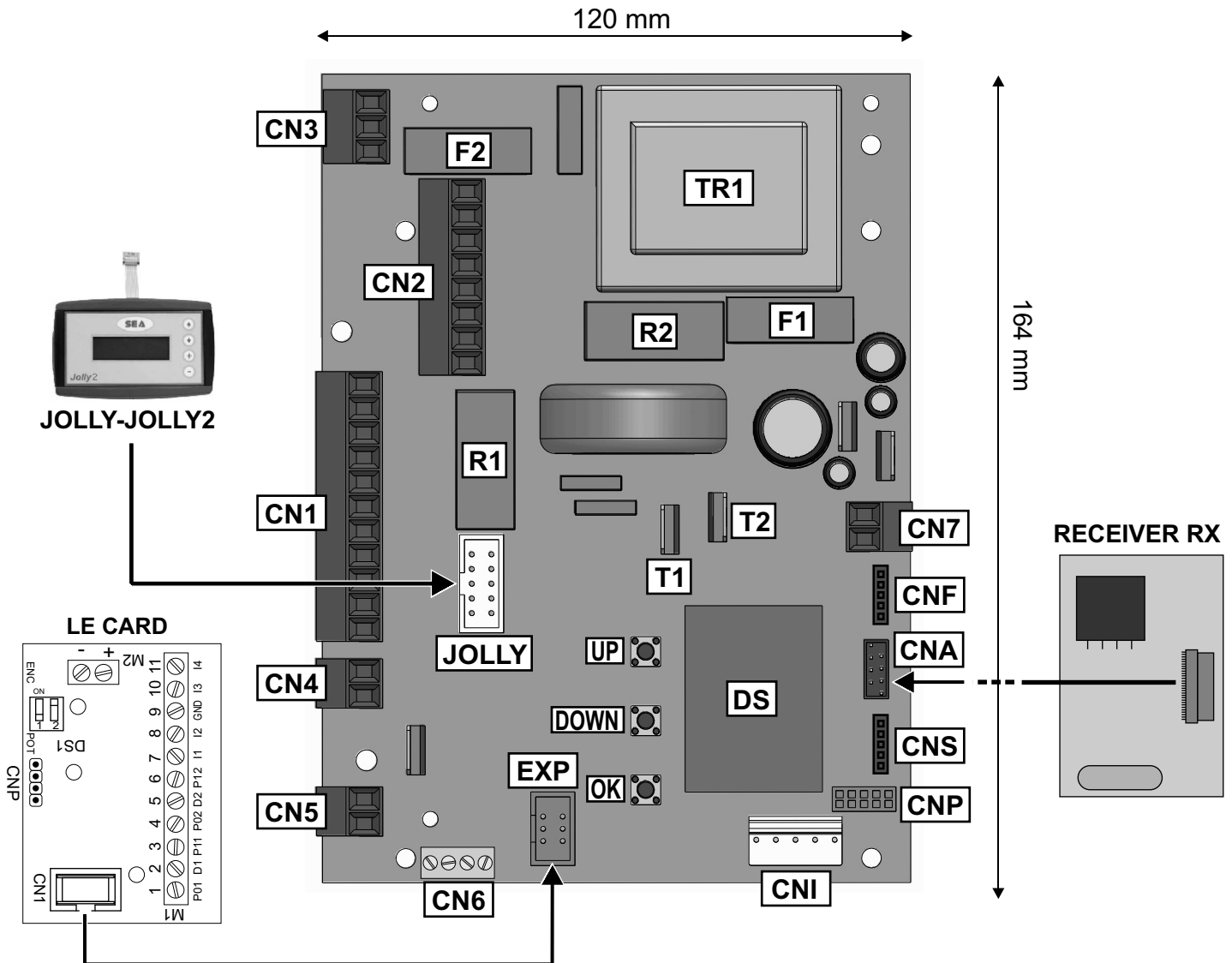

- CN1** = Input/output connectors
- CN2** = Motors, capacitors and courtesy light connector
- CN3** = Power supply connector
- CN4** = Flash led and electrolock connector
- CN5** = Safety edge connector
- CN6** = Limit switch connector
- CN7** = Connector antenna
- CNP** = Programming connector
- CNA** = Receiver module connector RX
- CNS** = Fix receiver connector
- CNI** = Plug-in receiver connector

- EXP** = Expansion module connector/LE Card
- JOLLY** = Jolly - Jolly 2 connector
- DS** = Programming display
- OK** = Programming button
- DOWN** = Programming button
- UP** = Programming button
- T1** = Motors piloting Triac
- T2** = Motors piloting Triac
- R1** = Motors comand relay
- R2** = Courtesy light comand relay
- F1** = Accessories 1A fuse
- F2** = 6.3AT fuse on 230V/10AT on 115V
- TR1** = Power transformer

# CONNECTIONS

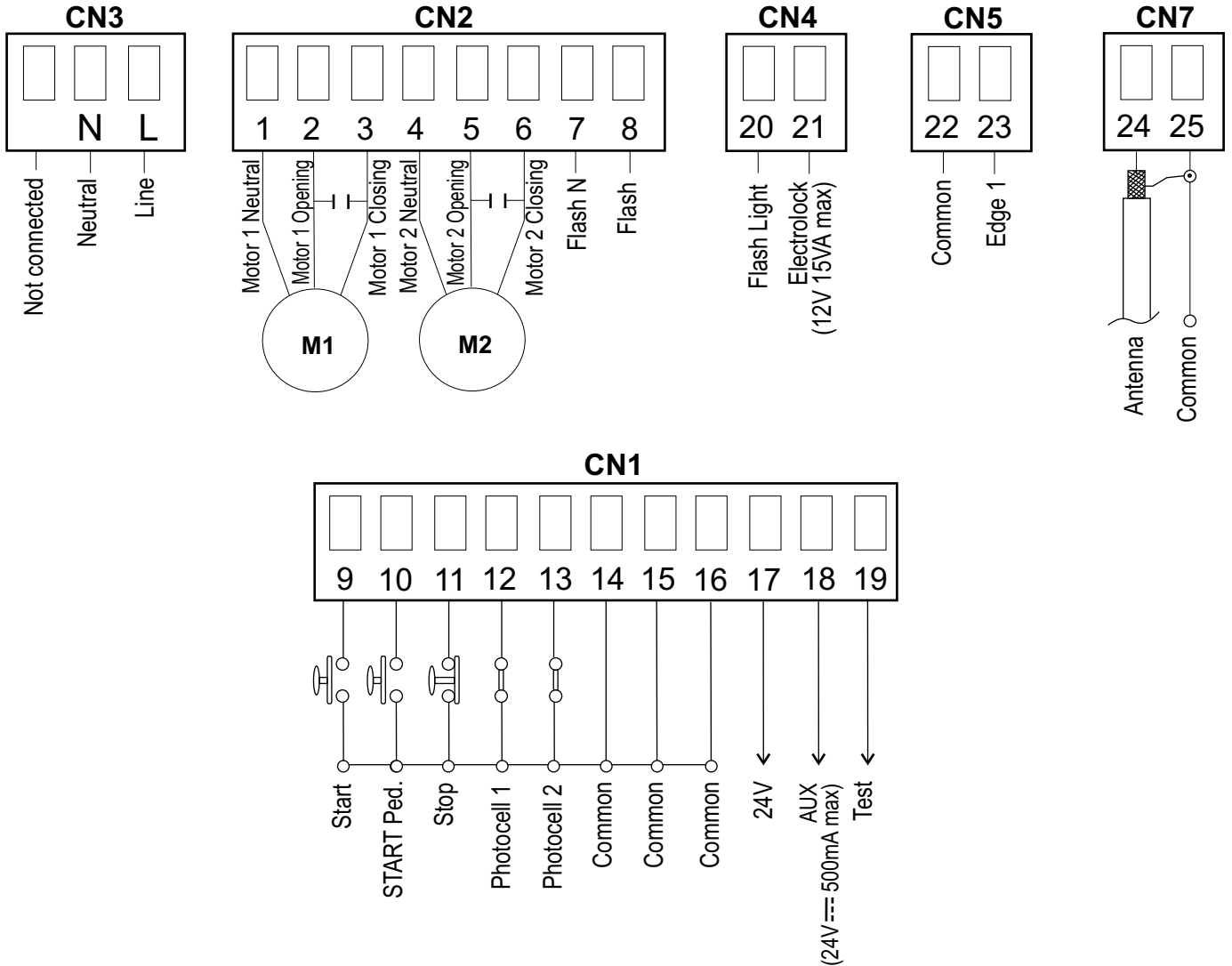

# JUMPERS

**WARNING:** The control unit is designed with the automatic detection of not used N.C. inputs (Photocells and Stop) except the SAFETY EDGE input. The exclude inputs in self-programming can be restored in the "Check inputs" menu without need to repeat the programming (page 36).

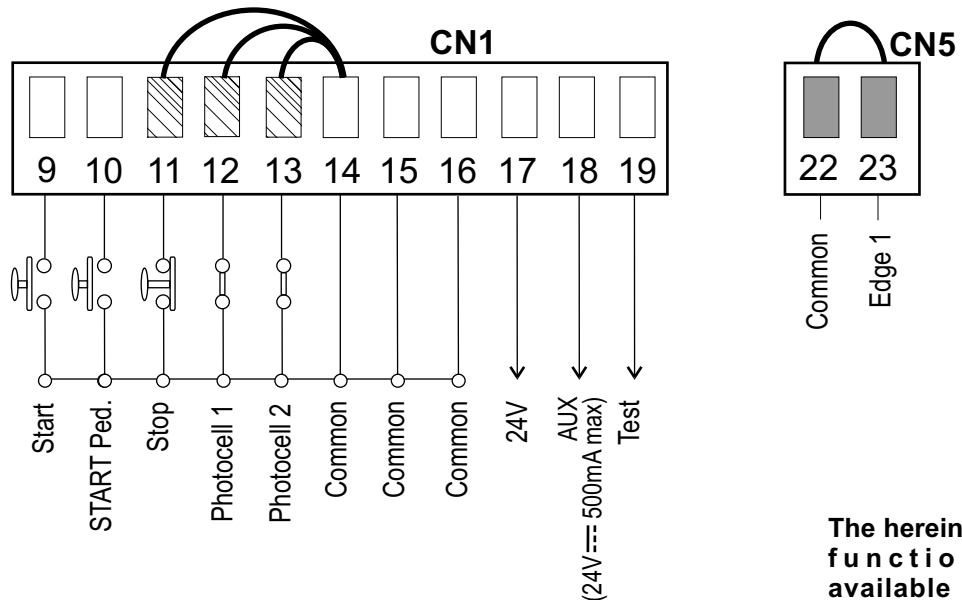

The herein reported functions are available starting from revision 016.

# PROGRAMMING QUICK START

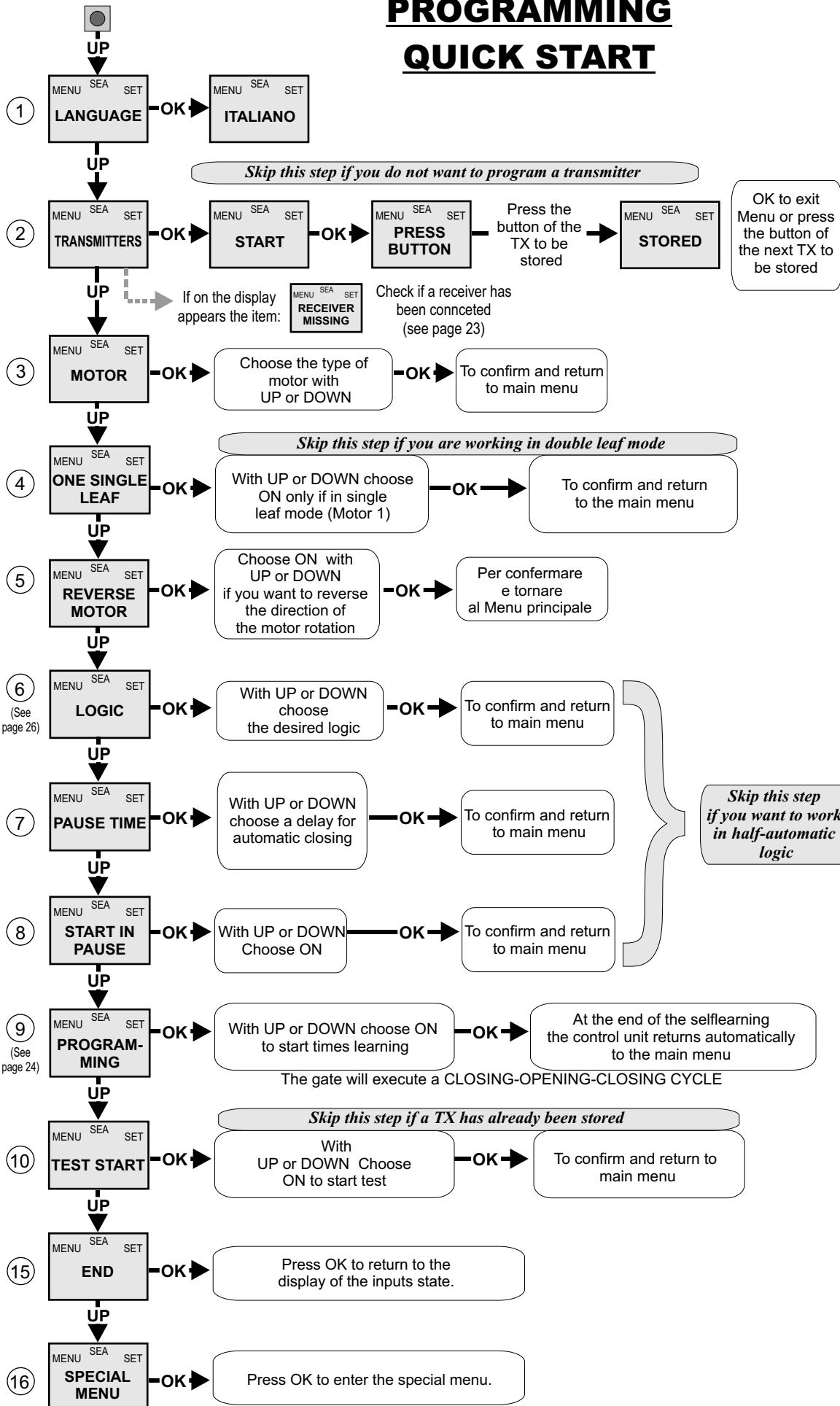
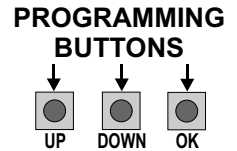

ALL OTHER PARAMETERS HAVE DEFAULT SETTINGS WHICH ARE USEFUL FOR THE 90% OF THE APPLICATIONS BUT CAN BE HOWEVER SET THROUGH THE SPECIAL MENU. FOR ENTERING INTO THE SPECIAL MENU MOVE ON ONE OF THE MENU AND PRESS THE UP AND DOWN BUTTONS AT THE SAME TIME FOR 5 S.

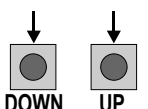

**MENU FUNCTIONS TABLE SWING 2 DG R2F**

MENU	SET	Description	Default	Set value
1 - LANGUAGE	<i>Italiano</i>	Italian	<i>Italiano</i>	
	<i>English</i>	English		
	<i>Français</i>	French		
	<i>Español</i>	Spanish		
	<i>Dutch</i>	Olandese		
2 - TRANSMITTERS	<i>Start</i>	Start	<i>Start</i> <i>Pedestrian Start</i>	
	<i>Pedestrian Start</i>	Pedestrian Start		
	<i>External module</i>	External module		
	<i>Stop</i>	Stop		
	<i>Unloch</i>	Storing of a command for unlocking an electric brake		
	<i>Delete a transmitter</i>	Delete single transmitter		
	<i>Clear memory</i>	Delete transmitter memory		
	<i>Move to eep</i>	Transfers the stored transmitters on the control unit to the external EEPROM (MEM) if inserted.		
3 - MOTOR	<i>Hydraulic</i>	Hydraulic	<i>Mechanic</i>	
	<i>Sliding</i>	Sliding		
	<i>Reversible sliding gate</i>	Reversible sliding gate		
	<i>Mechanic</i>	Mechanic		
	<i>Kougar</i>	Kougar motor		
4 - ONE SINGLE LEAF *	<i>Off</i>	Disabled	<i>Off</i>	
	<i>On</i>	In ON activates single leaf mode (Motor 1)		
5 - REVERSE MOTOR	<i>Off</i>	Synchronized right motor	<i>Off</i>	
	<i>On</i>	Synchronized left motor		
6 - LOGIC (See page 28)	<i>Automatic</i>	Automatic	<i>Automatic</i>	
	<i>Open-stop-close-stop-open</i>	Step by step type 1		
	<i>Open-stop-close-open</i>	Step by step type 2		
	<i>2 buttons</i>	Two buttons		
	<i>Safety</i>	Safety		
	<i>Dead man</i>	Dead man		
7 - PAUSE TIME	<i>Off</i>	OFF (semi-automatic logics)	<i>Off</i>	
	<i>1 240</i>	Setting from 1s to 4min.		
8 - START IN PAUSE	<i>Off</i>	In pause start is not accepted	<i>Off</i>	
	<i>On</i>	In pause start is accepted		
9 - PROGRAMMING (See page 27)	<i>Off On</i>	Times learning start	<i>Off</i>	
10 - TEST START	<i>Off On</i>	Start command	<i>Off</i>	
15 - END	Press OK to return to the display of the firmware version and to the one of inputs state.			
16 - SPECIAL MENU	Press OK to enter the special menu.			

**Note 1:** The \* indicates that the default value or the menu may change depending on the selected motor type.

## **WORKING TIMES SELF LEARNING**

**The control unit is pre-set with the default settings, to start the control unit with the DEFAULT settings just keep pressed the UP and DOWN buttons at the same time power supplying the control unit the display shows the message “Init”.**

**The DEFAULT settings are shown in the Menues table.**

### **WORKING TIMES SELFLEARNING THROUGH IMPULSES**

**ATTENTION:** This procedure is potentially dangerous and should only be performed by qualified people in safety conditions.

**NOTE:** The card is preset with the standard working times, therefore the automation can be started even without the times programming, simply by adjusting the timing on the display (see default times). In this procedure all used N.C. contacts must be kept closed.

- 1) Turn off electricity, release the motors and manually position the leaves on halfway.  
Reset the mechanical lock.
- 2) Connect the control board to the power supply
- 3) Select on the on-board display or JOLLY programmer, the type of motor that you are using as indicated in the display management (“Mechanic-Hydraulic”, etc).
- 4) If necessary also set the operation logic and the other parameters. If you want to program with a transmitter, store a transmitter before programming.
- 5) Select 9-PROGRAMMING on the display, press OK and than one of the UP or DOWN buttons.  
(If the motor starts in opening, remove and re-put power supply, select on the display 5-REVERSE MOTOR. And through the UP and DOWN button put it on ON, or if you have the Jolly programmer, activate the motor exchange function.)
- 6) At this point the gate will start the following cycle: CLOSING M2 - CLOSING M1 - OPENING M1 - OPENING M2 - CLOSING M2 - CLOSING M1. During cycle, to store the respective stops, press UP or DOWN or START at every point of stop of the leaf.
- 7) The self-learning is done.

### **SELFLEARNING OPERATION TIME WITH ENCODER / POTENTIOMETER**

When an encoder is installed, it is necessary to select “On” in the 32-ENCODER menu, when the potentiometer is installed, it is necessary to select “Potentiometer” in the 32-ENCODER menu. Start programming and make sure that leaf 2 starts as first in closing. The gate will automatically execute the following cycle: CLOSING M2 - CLOSING M1 - OPENING M1 - OPENING M2 - CLOSING M2 - CLOSING M1.

**Note:** For stop detection sensitivity setting refer to the special menu.

**Note 2:** With the potentiometer you can also make the learning giving impulses as described under point 6 of the preceding paragraph.

### **LEARNING WITH LIMIT SWITCH (Only on version with limit switch)**

When limit switches are mounted, the gate executes automatically the following cycle: CLOSING M2 - CLOSING M1 - OPENING M1 - OPENING M2 - CLOSING M2 - CLOSING M1.

Before starting the learning, make sure (through the test menu), that the relative limit switches of every leaf and every opening are employed.

Exe: For the M2 motor closing the limit switch M2 in closing must be employed.

## **FUNCTION LOGIC**

### ***AUTOMATIC LOGIC***

A start impulse opens the gate. A second impulse during the opening will not be accepted.

A start impulse during closing reverses the movement.

**NOTE 1: To have the automatic closing it is necessary to set a pause time, otherwise all the logic will be semi-automatic.**

**NOTE2: It is possible to choose, whether to accept or not, the start in pause, selecting in the MENU the item 8-START IN PAUSE and choosing ON or OFF. By default, the parameter is OFF.**

### ***SECURITY LOGIC***

A start impulse opens the gate. A second impulse during opening reverses the movement.

A start impulse during closing reverses the movement.

**NOTE 1: To have the automatic closing it is necessary to set a pause time, otherwise all the logic will be semi-automatic.**

**NOTE2: It is possible to choose, whether to accept or not, the start in pause, selecting in the MENU the item 8-START IN PAUSE and choosing ON or OFF. By default, the parameter is OFF.**

### ***STEP BY STEP TYPE 1 LOGIC***

The start impulse follows the OPEN-STOP-CLOSE-STOP-OPEN logic.

**NOTE 1: To have the automatic closing it is necessary to set a pause time, otherwise all the logic will be semi-automatic.**

**NOTE2: It is possible to choose, whether to accept or not, the start in pause, selecting in the MENU the item 8-START IN PAUSE and choosing ON or OFF. By default, the parameter is OFF.**

### ***STEP BY STEP TYPE 2 LOGIC***

The start impulse follows the OPEN-STOP-CLOSE -OPEN logic.

**NOTE 1: To have the automatic closing it is necessary to set a pause time, otherwise all the logic will be semi-automatic.**

**NOTE2: It is possible to choose, whether to accept or not, the start in pause, selecting in the MENU the item 8-START IN PAUSE and choosing ON or OFF. By default, the parameter is OFF.**

### ***DEAD MAN LOGIC***

The gate opens as long as the **START** button of opening is pressed; releasing it the gate stops. The gate closes as long as the button connected to the **PEDESTRIAN START** is pressed; releasing it the gate stops. To execute complete opening and/or closing cycles the related pushbuttons must be constantly pressed.

### ***2 PUSHBUTTONS LOGIC***

One start opens, one pedestrian start closes. In opening the closing will not be accepted. In closing a start command reopens, a pedestrian start command (closes) will be ignored.

## SPECIAL MENU

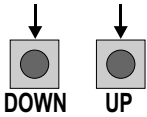

**PRESS AT THE SAME TIME FOR 5 SECONDS TO ENTER OR TO EXIT THE SPECIAL MENU**





### SPECIAL MENU FUNCTIONS TABLE SWING 2 DG R2F

For entering into the special menu move on one of the menu and press the UP and DOWN buttons at the same time for 5 s. For exiting the special menu press END or move on one of the menu and press the UP and DOWN buttons at the same time for 5 s.

MENU SP	SET	Description	Default	Set value
26 - LEAF DELAY IN OPENING *	Off 6	Setting from OFF to 6 seconds	1,5	
27 - LEAF DELAY IN CLOSING *	Off 20	Setting from OFF to 20 seconds	2,5	
28 - OPENING TORQ 1 *	10 100	M1 opening torque Note: with hydraulic motors the torque will be on 100%	75	
29 - CLOSING TORQ 1 *	10 100	M1 closing torque Note: with hydraulic motors the torque will be on 100%	75	
30 - OPENING TORQ 2 *	10 100	M2 opening torque Note: with hydraulic motors the torque will be on 100%	75	
31 - CLOSING TORQ 2 *	10 100	M2 closing torque Note: with hydraulic motors the torque will be on 100%	75	
32 - ENCODER *	On	In ON enables the Encoder, in OFF it's disabled	Off	
47 - ENCODER PAR.1 *	xxx.	Encoder impulses during operation (Motor 1).		
48 - ENCODER TOT.1 *	xxx.	Encoder impulses stored in programming (Motor 1).		
49 - ENCODER PAR.2 *	xxx.	Encoder impulses during operation (Motor 2).		
50 - ENCODER TOT.2 *	xxx.	Encoder impulses stored in programming (Motor 2).		
32 - ENCODER *	Potentiometer	Enables the reading of the potentiometer with LE card.	Off	
51 - I.PAR.M1 *	-----	Reports the current position of the potentiometer on the leaf of motor 1. This parameter is useful for seeing if the potentiometer is read correctly.		
52 - I.AP.M1 *	-----	Reports the impulses stored by the control unit when the leaf of motor 1 is fully open.		
53 - I.CH.M1 *	-----	Reports the impulses stored by the control unit when the leaf of motor 1 is fully close.		



MENU SP	SET	Description	Default	Set value
54 - I.PAR.M2 *	-----	Reports the current position of the potentiometer on the leaf of motor 2. This parameter is useful for seeing if the potentiometer is read correctly.		
55 - I.AP.M2 *	-----	Reports the impulses stored by the control unit when the leaf of motor 2 is fully open.		
56 - I.CH.M2 *	-----	Reports the impulses stored by the control unit when the leaf of motor 2 is fully close.		
32 - ENCODER *	Off	In ON enables the Encoder, in OFF it's disabled	Off	
	65 - OPENING TIME MOTOR1	Indicates the working times selflearning in opening and closing (Motor 1). With UP or DOWN it is possible to increase or reduce the working times.		
	66 - CLOSING TIME MOTOR1			
	67 - OPENING TIME MOTOR2	Indicates the working times selflearning in opening and closing (Motor 2). With UP or DOWN it is possible to increase or reduce the working times.		
	68 - CLOSING TIME MOTOR2			
33 - OPENING SENSITIVITY MOTOR1 *	10% (Fast intervention) 99% (Slow intervention)	Adjusts the intervention time of the Encoder / Potentiometer on Motor 1 in opening	Off	
	Off (Intervention excluded)	Disabled		
34 - CLOSING SENSITIVITY MOTOR1 *	10% (Fast intervention) 99% (Slow intervention)	Adjusts the intervention time of the Encoder / Potentiometer on Motor 1 in closing	Off	
	Off (Intervention excluded)	Disabled		
35 - OPENING SENSITIVITY MOTOR2 *	10% (Fast intervention) 99% (Slow intervention)	Adjusts the intervention time of the Encoder / Potentiometer on Motor 2 in opening	Off	
	Off (Intervention excluded)	Disabled		
36 - CLOSING SENSITIVITY MOTOR2 *	10% (Fast intervention) 99% (Slow intervention)	Adjusts the intervention time of the Encoder / Potentiometer on Motor 2 in closing	Off	
	Off (Intervention excluded)	Disabled		
38 - POT. THRESHOLD OPENING 1 *	1 100	Adjusts the threshold of the potentiometer intervention. The parameter self-determines in learning but can also be adjusted later. The lower the value, the slower will be the response of the potentiometer. The parameter can be set as maximum threshold at the value read on the DEBUG VPI, VP2 menu.		
39 - POT. THRESHOLD CLOSING 1 *				
40 - POT. THRESHOLD OPENING 2 *				
41 - POT. THRESHOLD CLOSING 2 *				

MENU SP	SET	Description	Default	Set value
42 - POT. SLOWDOWN THRESHOLD OPENING1 *	1 100	Adjust the threshold of the potentiometer in slowdown. By default this value is set on 1 and can be increased manually up to the maximum value read on the DEBUG VPI, VP2 menu.		
43 - POT. SLOWDOWN THRESHOLD CLOSING1 *				
44 - POT. SLOWDOWN THRESHOLD OPENING 2 *				
45 - POT. SLOWDOWN THRESHOLD CLOSING 2 *				
59 - OPENING SLOWDOWN 1	Off 50	From OFF to 50% of the stroke	20	
60 - CLOSING SLOWDOWN 1	Off 50	From OFF to 50% of the stroke	20	
61 - OPENING SLOWDOWN 2 *	Off 50	From OFF to 50% of the stroke	20	
62 - CLOSING SLOWDOWN 2 *	Off 50	From OFF to 50% of the stroke	20	
63 - DECELERATION	0 %  100% 	Adjusts the transition between the set speed and slowdown	100%	
64 - ACCELERATION	0 %  100% 	Acceleration ramp. Adjusts the motor start.	100%	
69 - ANTI OVERLAP *	Off	Desactivate the leaves anti-overlapping control, allowing separate control of the two leaves.	Off	
	On	Activate the leaves anti-overlapping control		
70 - OPENING POSITION RECOVERY *	0 20	Retrieves the inertia of the motor in opening after Stop or reversing	1 %	
71 - CLOSING POSITION RECOVERY *	0 20	Retrieves the inertia of the motor in closing after Stop or reversing	1 %	
72 - OPENING TOLERANCE MOTOR1 *	0 100	Adjust the tolerance between stop and obstacle Motor 1 opening.	0	
73 - CLOSING TOLERANCE MOTOR1 *	0 100	Adjust the tolerance between stop and obstacle Motor 1 closing.	0	
74 - OPENING TOLERANCE MOTOR2 *	0 100	Adjust the tolerance between stop and obstacle Motor 2 opening.	0	
75 - CLOSING TOLERANCE MOTOR2 *	0 100	Adjust the tolerance between stop and obstacle Motor 2 closing.	0	
76 - PUSHING STROKE	Off 3	From OFF to 3 seconds	Off	
77 - LOCK TIME	Off 5	Sets the lock release time from 0 to 5 s	3	
78 - LOCK	Only opening	Active only before opening	Opening and closing	
	Only closing	Active only before closing		
	Opening and closing	Active before opening and closing		

MENU SP	SET	Description	Default	Set value
79 - ANTI INTRUSION	<i>Only opening</i>	If you force the gate manually, the control unit starts the motor to restore the state of the gate before forcing.	<i>Off</i>	
	<i>Only closing</i>			
	<i>Opening and closing</i>			
	<i>Off</i>			
80 - PUSHOVER *	<i>Off</i>	Allows the leaf to make an extra move at maximum torque to ensure the tightening.	<i>Off</i>	
	<i>Opening and closing</i>			
	<i>Only opening</i>			
	<i>Only closing</i>			
81 - PERIODICAL PUSHOVER *	<i>Off 8</i>	Allows the repetition of the Pushover function at a distance of time adjustable from 0 to 8 hours at hourly intervals	<i>Off</i>	
82 - MOTOR RELEASE *	<i>Off</i>	Disabled	<i>0.1</i>	
	<i>0.1 3.0</i>	Setting from 1 to 3		
83 - EXTRA TIME	<i>0.0 s 10 s</i>	If limit switches are present it adds an extra time to the movement of the motors after the reading of the limit switches.	<i>0.0 s</i>	
84 - BRAKE *	<i>----</i>	Adjusts the braking on the limit switches	<i>0</i>	
85 - PREFLASHING	<i>Only closing</i>	Pre-flashing only active before closing	<i>Off</i>	
	<i>0.0 5.0</i>	Pre-flashing time		
86 - FLASHING LIGHT	<i>Normal</i>	Normal	<i>Normal</i>	
	<i>Light</i>	Control lamp		
	<i>Always</i>	Always ON		
	<i>Buzzer</i>	Buzzer		
87 - FLASHING LIGHT AND TIMER	<i>Off</i>	The flashing light remains OFF with the active timer and open gate	<i>Off</i>	
	<i>On</i>	The flashing light remains ON with active timer and open gate		
88 - COURTESY LIGHT	<i>In cycle</i>	Courtesy light in cycle	<i>In cycle</i>	
	<i>1 240</i>	Courtesy light setting from 1s to 4min. <b>Nota:</b> With SEM2 external card only.		
89 - TRAFFIC LIGHT RESERVATION	<i>Off on</i>	When setting this function the pedestrian input will be activated to work on the auxiliary board SEM (traffic light management).	<i>Off</i>	
90 - PEDESTRIAN OPENING	<i>5 100</i>	Setting from 5 to 100	<i>100</i>	
91 - PEDESTRIAN PAUSE	<i>= Start</i>	Pause in pedestrian opening same as in total opening	<i>= Start</i>	
	<i>Off</i>	Disabled		
	<i>1 240</i>	Setting from 1s to 4 min.		

MENU SP	SET	Description	Default	Set value
92 - TIMER	<i>Off</i>	Transforms the selected input in an input on which to connect an external clock.	<i>Off</i>	
	<i>On photo2</i>			
	<i>On pedestrian entry</i>			
94 - 24V AUX	<i>Always</i>	AUX output always power supplied	<i>Always</i>	
	<i>In cycle</i>	AUX output active only during cycle		
	<i>Opening</i>	AUX output power supplied only during opening		
	<i>Closing</i>	AUX output power supplied only during closing		
	<i>In pause</i>	AUX output power supplied only during pause		
	<i>Positive brake management</i>	Positive Electrobrake		
	<i>Negative brake management</i>	Negative Electrobrake		
	<i>Gate open warning light</i>	1 flash per sec. in opening 2 flashes per sec. in closing Steady lit in Stop or Open.		
95 - FOTOTEST	<i>Photo1</i>	Auto-test active only on Photo1	<i>Off</i>	
	<i>Photo2</i>	Auto-test active only on Photo2		
	<i>Photo1-2</i>	Auto-test active on Photo1 and Photo2		
	<i>Off</i>	Disabled		
96 - EDGE AUTOTEST	<i>Edge1</i>	Test enabled on edge 1	<i>Edge1</i>	
	<i>Off</i>	Disabled		
97 - PHOTO1	<i>Closing</i>	Photocell active in closing	<i>Closing</i>	
	<i>Opening and closing</i>	Active in opening and closing		
	<i>Stop</i>	Photocell active before opening		
	<i>Stop and close</i>	The photocell stops in closing and closes when released		
	<i>Close</i>	The photocell gives a command to close during opening, pause and closing		
	<i>Pause reload</i>	The photocell charging the pausing time		
	<i>Delay pause time</i>	If the photocell is occupied during opening, pause or closing, the gate reopens completely and closes without observing the pause time.		

MENU SP	SET	Description	Default	Set value
98 - PHOTO2	<i>Closing</i>	Photocell active in closing	<i>Opening</i>	
	<i>Opening and closing</i>	Active in opening and closing		
	<i>Stop</i>	Photocell active before opening		
	<i>Stop and close</i>	The photocell stops in closing and closes when released		
	<i>Close</i>	The photocell gives a command to close during opening, pause and closing		
	<i>Pause reload</i>	The photocell charging the pausing time		
	<i>Delay pause time</i>	If the photocell is occupied during opening, pause or closing, the gate reopens completely and closes without observing the pause time.		
100 - EDGE1	<i>Normal</i>	Normal N.C. contact	<i>Normal</i>	
	<i>8K2</i>	Edge is active and protected by a 8k2 resistor		
102 - EDGE1	<i>Opening and closing</i>	Active in opening and closing	<i>Opening and closing</i>	
	<i>Only opening</i>	Active only in opening		
	<i>Only closing</i>	Active only in closing		
104 - SELECT LIMIT SWITCH	<i>Automatic</i>	Limit switch in automatic recognition	<i>Automatic</i>	
	<i>Only opening</i>	Only limit switch in opening present		
	<i>Only closing</i>	Only limit switch in closing present		
	<i>Motor internal</i>	To be activated if there is a limit switch that stops the motor phase.		
106 - DIAGNOSTICS	<i>1 10</i>	Shows last event (See alarms table)		
107 - MAINTENANCE CYCLES	<i>100 10E4</i>	Setting from 100 to 100000	<i>10E4</i>	
108 - PERFORMED CYCLES	<i>0 10E9</i>	Reports the executed cycles. Keep pressed OK to reset the cycles	<i>0</i>	
112 - PASSWORD	<i>----</i>	Allows the entering of a password blocking the control unit parameters modification.	<i>----</i>	
120 - BASIC MENU	Press OK to exit the special menu. The special menu switches off automatically after 20 minutes.			

**Note 1:** The \* indicates that the default value or the menu may change depending on the selected motor type.

**Note 2:** After initialization the parameters "motor type" and "limit switch type" remain on the value chosen in the setup program.

## POTENTIOMETER MANAGEMENT (Position Gate)

**(Available from revision 013 only on prepared motors)**

The position gate ensures the correct position of the gate and the inversion on the obstacle, helping the installer to pass the certification of the automation.

To connect the potentiometer you must use the LE card (Cod.23001256) and set with Dip Switches 1 and 2 both in OFF.

With the potentiometer it is possible to access the hidden DEBUG menu to check the maximum settable value as threshold in normal and slowdown speed.

To access this menu you have to press, in the menu that displays the firmware version, UP and OK at the same time until the menus VP1 speed of potentiometer 1 and VP2 speed of potentiometer 2 will appear.

To view the speed of the potentiometer on the related menu, press OK.

To exit the DEBUG menu go to END and press OK.

If the reading of the potentiometer is reversed relative to the movement of the motor, on the display will appear the alarm "Potentiometer direction" and you will have to reverse the brown wire with the green one and repeat programming..

For a quick inversion on the obstacle you have to lower the sensitivity parameters.

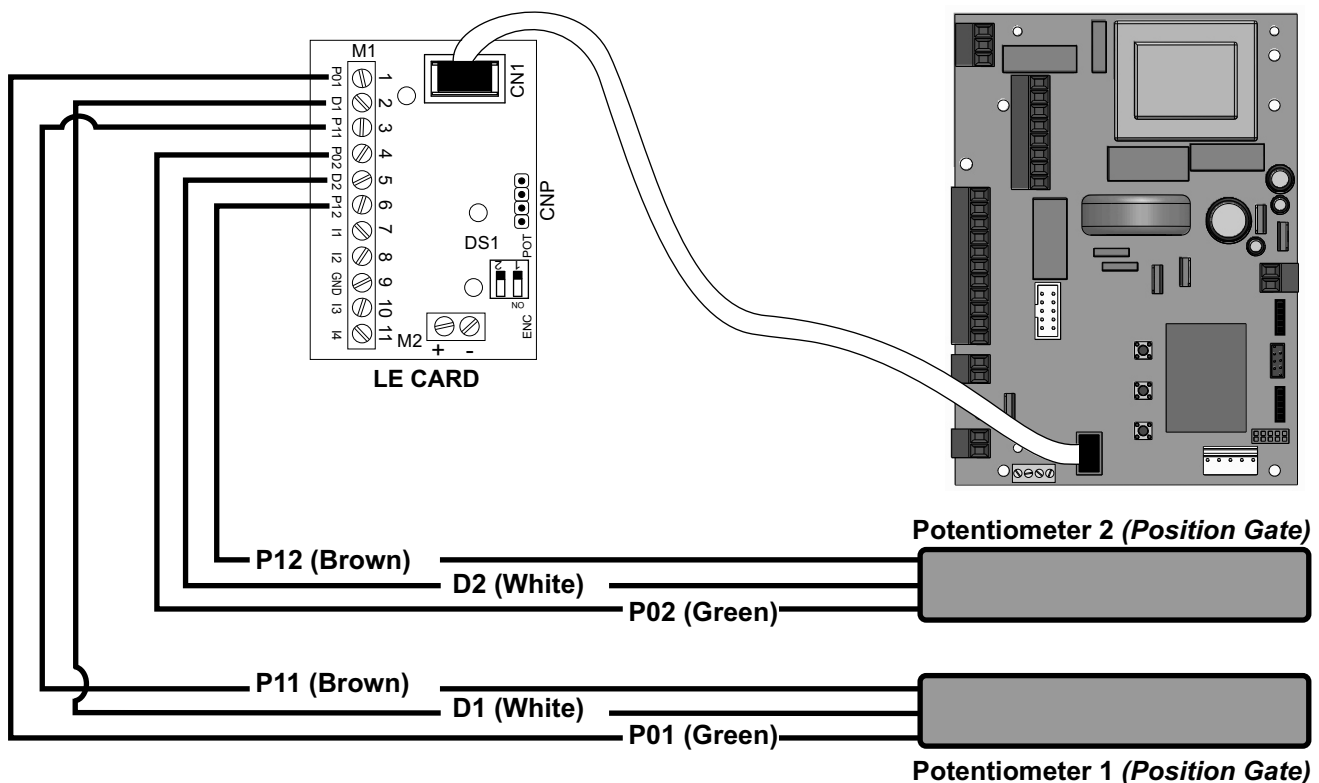

## PASSWORD ENTERING MANAGEMENT

With a new control unit all menus can be displayed and set and the password will be disabled.

Selecting one of the Menus and keeping UP and DOWN pressed at the same time for 5 seconds, you will access the SP Menu containing the 112-PASSWORD Submenu.

Pressing OK in the 112-PASSWORD Menu, you will proceed with the entering of the numeric code of the 4-digit password.

Use UP and DOWN to increase or decrease the number, press OK to confirm it and you will pass automatically to the entering of the next number. Pressing OK after the last entered number the word "Sure?" appears, confirm the activation of the password and the message OK appears, pressing UP or DOWN instead you can cancel the operation and "No operation" will appear on the display.

Once entered the password, it will be definitively activated, once the display switch off timeout has expired, or by turning off and on again the control unit. Once the password has been activated, the menus of the display can be only displayed but not set. To unlock them you must enter the correct password in the 112-PASSWORD menu, if the password is wrong the message "Error" will appear.

At this point, if the password has been entered correctly, the menus will be unlocked and it will be possible to change the parameters of the control unit again.

If the control unit has been unlocked through 112-PASSWORD Menu, it is possible to enter a new and different password, using the same entering process as for the first one; at this point, the old password will no longer be valid.

If the password has been forgotten, the only way to unlock the control unit is to contact the SEA technical assistance, which will assess whether to provide the procedure to unlock the control unit or not.

**Note:** The password cannot be set through the Jolly or Jolly 2 terminal.

# MENU FOR INPUT CHECK

The settings of the control unit are made through the UP, DOWN and OK buttons. The UP and DOWN buttons to scroll through the MENUS and SUBMENUS. By pressing OK you enter from MENU into SUBMENU and confirm the choice.

Moving in the 1-LANGUAGE menu pressing the UP and DOWN buttons at the same time you access the SP MENU for special settings.

Moving in the 1-LANGUAGE menu pressing the OK button for 5 seconds, you enter the CHECK MENU, where you can check the operating status of all inputs.

Initial system

**U.022** Software Version

Programming example

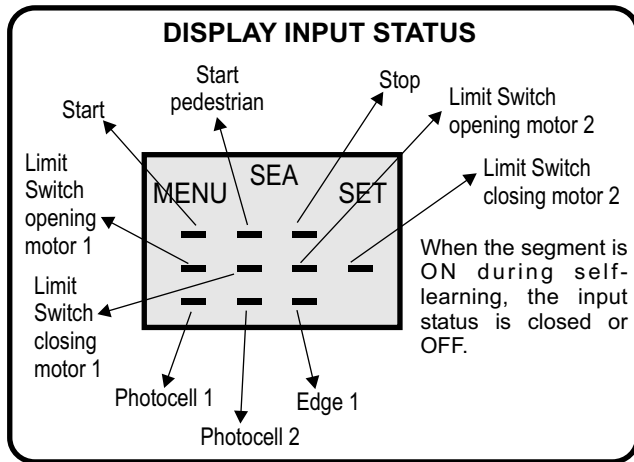
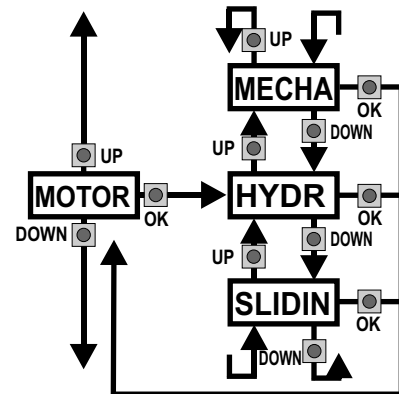

**Note:** The limit switches will be displayed only on version with limit switch.

## MENU FUNCTION TABLE CHECK SWING 2 DG R2F INPUTS

To access the Menu for input check keep pressed OK for about 5 seconds.

MENU	Description	Description
START	Start test	The contact must be a N.O. Contact . When activating the related command on the display SET lights up, the input works. If SET is always on, check the wirings.
STOP → OK ↘	Enabled Blocked	Stop test
PEDESTRIAN START	Pedestrian start test	The contact must be a N.O. Contact. When activating the related command on the display SET lights up, the input works. If SET is always on, check the wirings.
EDGE1 → OK ↘	Enabled Blocked	Safety edge1 test
PHOTO1 → OK ↘	Enabled Blocked	Photocell 1 test
PHOTO2 → OK ↘	Enabled Blocked	Photocell 2 test
LIMIT SWITCH OPENING 1	M1 Opening limit switch test	The contact must be a N.C. Contact. When activating the related command on the display SET lights up, the input works. If SET is always on, make sure that the contact is a N.C. Contact. Menu active only on version with limit switches.
LIMIT SWITCH CLOSING 1	M1 Closing limit switch test	The contact must be a N.C. Contact. When activating the related command on the display SET lights up, the input works. If SET is always on, make sure that the contact is a N.C. Contact. Menu active only on version with limit switches.
LIMIT SWITCH OPENING 2	M2 Opening limit switch test	The contact must be a N.C. Contact. When activating the related command on the display SET lights up, the input works. If SET is always on, make sure that the contact is a N.C. Contact. Menu active only on version with limit switches.
LIMIT SWITCH CLOSING 2	M2 Closing limit switch test	The contact must be a N.C. Contact. When activating the related command on the display SET lights up, the input works. If SET is always on, make sure that the contact is a N.C. Contact. Menu active only on version with limit switches.
END		Exit menu

**Note:** If the **Stop, Photocell 1 and Photocell 2, Edge 1** contacts are not bridged in self-learning, they will be deactivated and can be reactivated through this menu, without repeating times self-learning.

# RADIO TRANSMITTER SELF LEARNING

## WITH RECEIVER ON BOARD OF CONTROL UNIT

**⚠ WARNING:** Make the radio transmitters programming before you connect the antenna and insert the receiver into the special CMR connector (if available) with turned off control unit.

With RF UNI and RF UNI PG module it will be possible to use both Coccinella Roll Plus transmitters and radio transmitters with fixed code. The first memorized radio transmitter will determine the type of the remaining radio transmitters.

If the receiver is a Rolling Code, press twice the button of the radio transmitter that you want to program to memorize the first TX.

In the case of transmitters with fixed code it is necessary to press 1 time the button of the transmitter you want to program to store the first remote control

**Notes:**

- Enter radio transmitters learning only when the working cycle stops and the gate is closed.
- You can store max. 2 of the available 4 functions. If the control unit receives a code which was already associated to another function it will be updated with the new function.

<b>RF UNI</b>	<b>16 USERS</b> Whitout memory <b>800 USERS</b> With additional memory MEM
<b>RF UNI PG</b> <i>Old Model</i>	<b>100 USERS</b> Fixed code <b>800 USERS</b> Roll Plus
<b>RF UNI PG</b> <i>New model</i>	<b>800 UTENTI</b> Fixed code <b>800 UTENTI</b> Roll Plus

**TABLE EXAMPLE**

Transmitter Memory location	1	2	3	4	Serial number	Customer
0						
1						
2						
3						

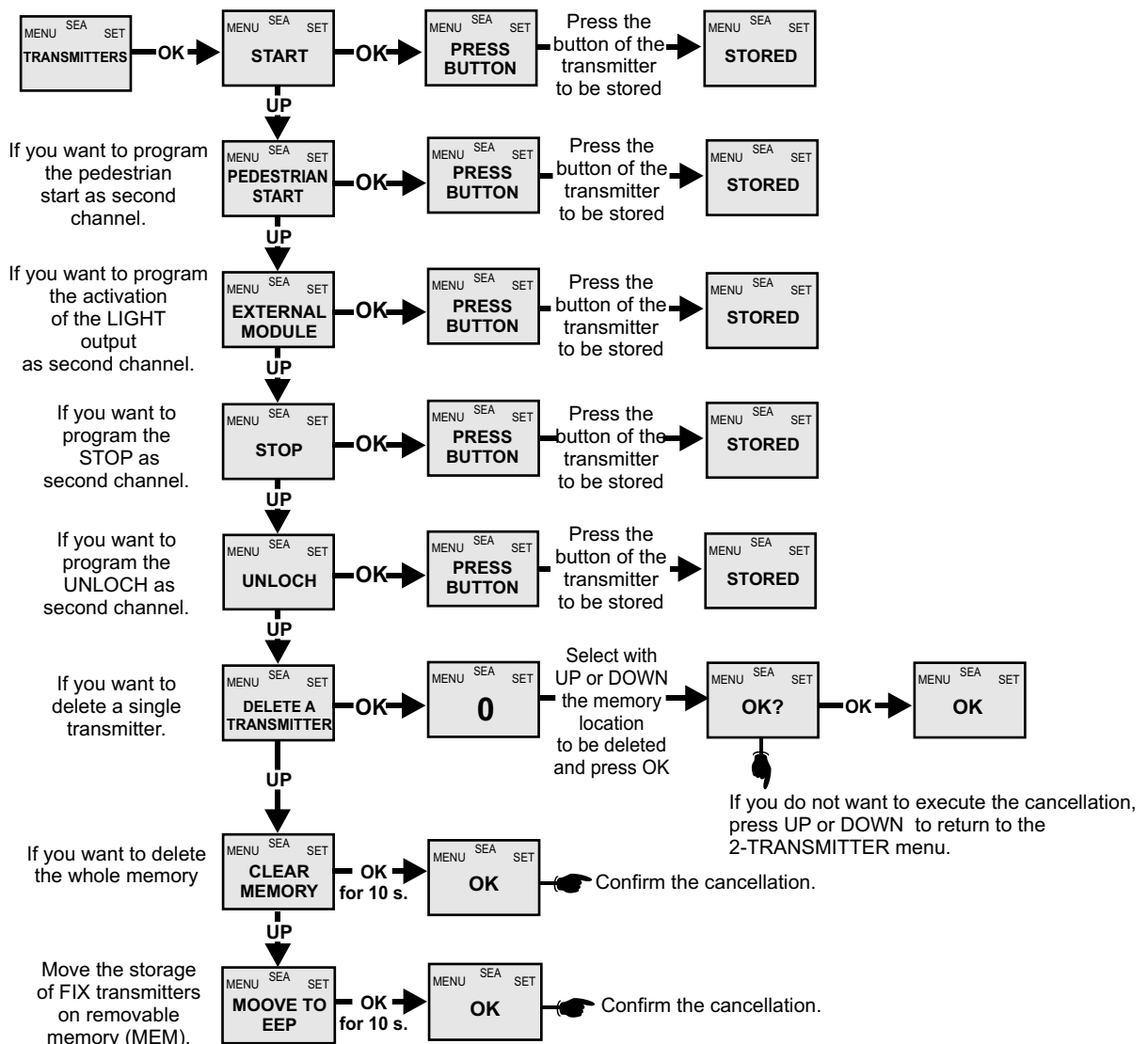



# RADIO TRANSMITTER SELF LEARNING WITH RECEIVER RF FIX ON BOARD OF CONTROL UNIT

**⚠ WARNING:** Make the radio transmitters programming before you connect the antenna and insert the receiver into the special CNS connector (if available) with turned off control unit.

**With the RF FIX module it will be possible to use only radio controls with fixed code.**

Select through the display 2-TRANSMITTERS and press OK, now select with the UP and DOWN buttons, the command to which you want to associate the button (it is possible to associate max. 2 commands) and press OK to confirm the choice, now press the button of the radio transmitter which you want to associate. If the storage is successful, the display will show "Stored".

In the 2-TRANSMITTERS MENU it is possible to select "Start" (to associate a Start command), "Pedestrian start" (to associate a Pedestrian Start), "Stop" (To associate the STOP command to the TX), "Clear memory" (To delete all TX), "Delete a transmitters" (To delet the single transmitter only if it is a Rolling Code Plus), "Unloch" (to associate the release of the electric brake to the transmitter). To release the electric brake it is necessary to give three consecutive pulses, the 4th will reactivate the lock of the electric brake.

**Notes:**

- Enter radio transmitters learning only when the working cycle stops and the gate is closed.
- It will be possible to memorize up to max. 16 codes (buttons) adding the MEM memory it will be possible to store up to 496 different codes.
- You can store max. 2 of the available 4 functions. If the control unit receives a code which was already associated to another function it will be updated with the new function.

**DELETE TRANSMITTERS FROM THE RECEIVER**

With modules different from RF FIX, it will be possible to delete only the entire memory of the receiver.

Proceed as follows: select from the menu 2-TRANSMITTERS: "Clear memory" and hold the OK button until the display shows the message "OK".

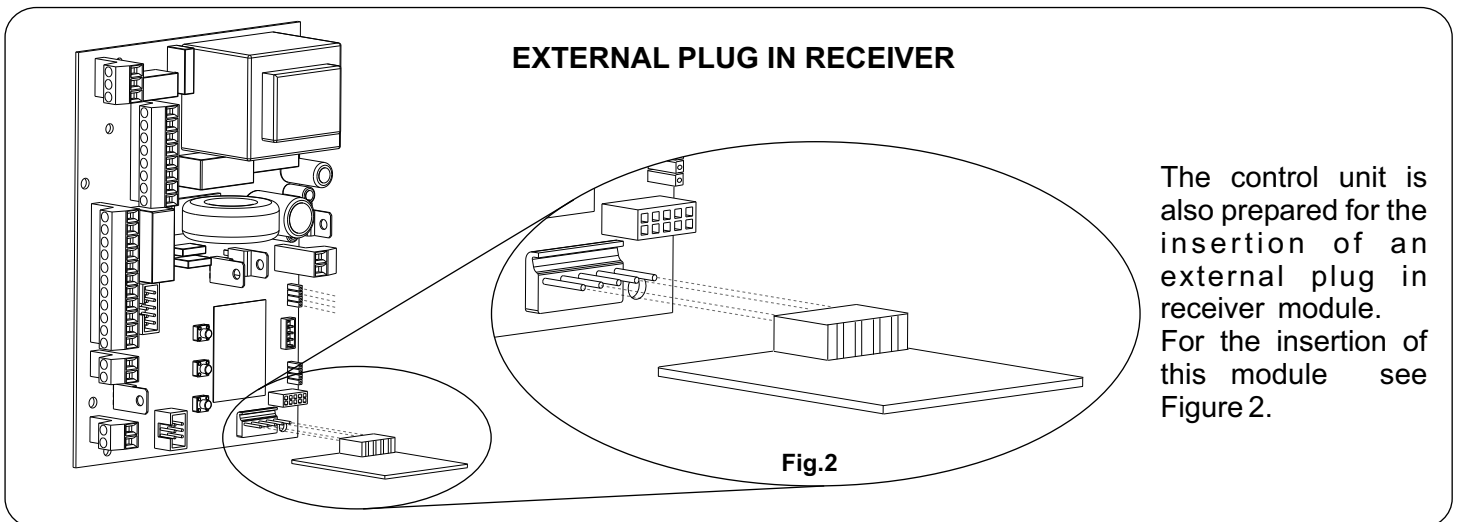
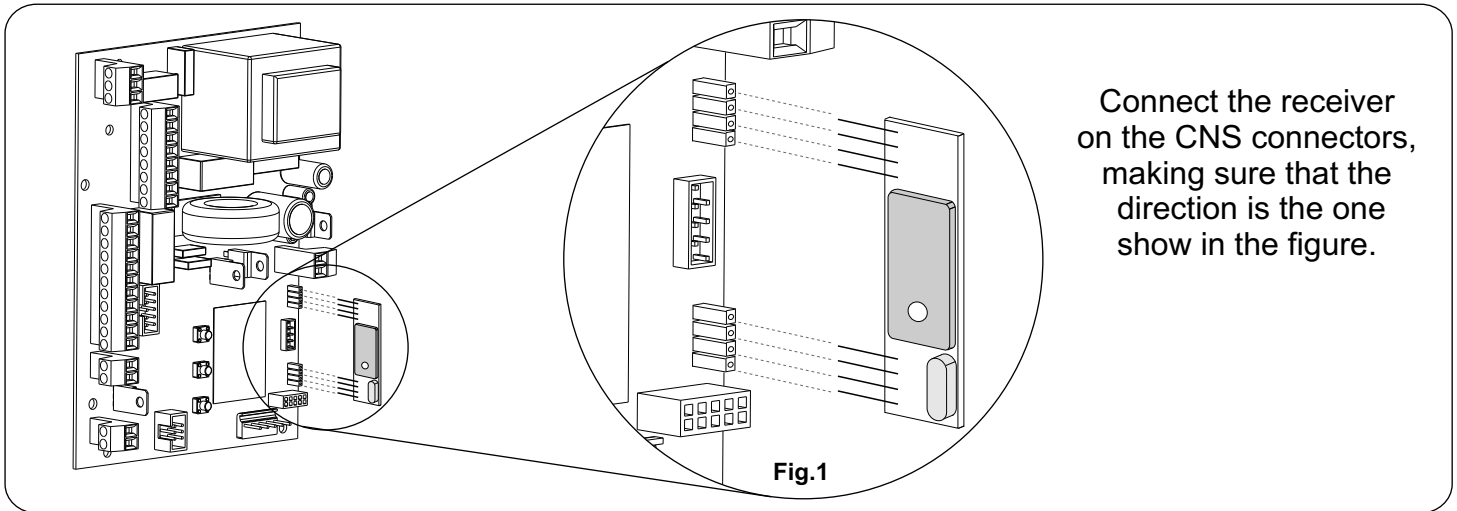

# **START - STOP - PEDESTRIAN START - ANTENNA - PHOTOCELL**

## **Photocell 1 and Photocell 2 Connections**

**Note: If the photocells are not connected, it is not necessary put a jumper between the clamps (12, 13 and 14 of the CN3 terminal)**

24VA = AUX 24V --- (Accessories) 500 mA max    COM = 0V    PH1 = Photocell contact 1  
PH2 = Photocell contact 2

**Note:** For the autotest in the 95-FOTOTEST menu select the photocell or the photocells on which you want to perform it. Self-test is possible only when connecting the negative of the photocell transmitter to the TEST input. The default setting of the photocell 1 is in "Closing" and the one of the photocell 2 is in "Opening and closing". The photocell 2 can also be set as TIMER (see TIMER function).

## **OPTIONS ON FOTO1 and FOTO2 adjustable on on-board display or with JOLLY terminal.**

**"Closing":** if occupied, reverses the movement in closing, during pause it prevent the closing.

**"Opening and closing":** If activated the photocell blocks the movement as long as it's busy, when released the opening continues.

**"Stop":** When activated before the opening the photocell blocks the automation as long as it is busy, during the opening it will be ignored. In closing the intervention of the photocell causes the reopening.

**"Stop and close":** in opening it is not active; in pause are activated it commands the closing when released, otherwise it's not active; in closing it stops the movement as long as it is busy, when released the closing continues.

**"Close":** The photocell stops the gate as long as it is occupied in both opening and closing, when released it gives a closing command (Closing one second after release of the photocell).

**"Pause reload":** If occupied, during pause it recharges the timer of pause. In closing it reverses the movement.

**"Delay pause time":** If the photocell is occupied during opening, pause or closing, the gate reopens completely and closes without observing the pause time.

## **Options 24VA --- can be set with on-board Display or with Jolly device.**

It is possible to chose when having tension on the 24VA output. The options are: **always, only during opening, only during cycle, only before opening, only during pause.**

## **PEDESTRIAN START (N.O.) The pedestrian start can be connected between the connectors 10 and 14 of the CN3 terminal .**

This input allows a partial opening, the opening space can be set through the on-board display or through the JOLLY device.

**Note1:** The contact for partial opening is a N.O. Contact (Normally open). Holding START starts the TIMER function, releasing the pedestrian start, the operator repeats the pause and then performs the closing. In the case of triggering a safety device the timer will automatically reset after 6 seconds.

**Note2:** In 2 BUTTONS logic it is necessary to keep pressed the Start Ped. to re-close the automation.

**Note3:** In deadman logic this button executes the re-closing if you keep it pressed.

**Note4:** When closed during pause, the gate will reclose only after this input has been reopened.

**TIMER activation:** This input can be transformed into TIMER (See TIMER).

## **STOP (N.C.) The STOP is connected between the clamps 11 and 14 of the CN3 terminal .**

When pressing this button the motor immediately stops in any condition/position. To re-start the movement give a start command. After a stop the motor always re-starts in closing.

## **START (N.O.) The START is connected between connector 9 and 14 of the CN 3 terminal.**

An impulse given to this contact opens and closes the automation depending on the selected logic, it can be given by a keyswitch, a keypad, etc. Holding START starts the TIMER function, releasing the start, the operator repeats the pause and then performs the closing. To connect the other devices refer to the related instructions leaflets. (ie. loop detectors and proximity switches). In the case of triggering a safety device the timer will automatically reset after 6 seconds.

**Note1:** In DEADMAN logic keep pressed the Start for the opening of the automation.

**Note2:** In 2 BUTTONS logic this button performs the opening.

## **TIMER**



Can be activated through the on-board display or through the Jolly programmer. In both cases it's a N.O. contact which provokes the opening of the automation keeping it open as long as it is activated. When it's released, after having paused for the set pausing time the gate recloses. The TIMER can be activated on the inputs FOTO2, PEDESTRIAN START or keeping busy the START input.

**Note1:** When activated on the pedestrian entry, the pedestrian will be OFF also on the radio transmitter.

**Note2:** In the event of an intervention of a security device during the timer (Stop, amperometric, Edge), a start impulse restores the movement. **Note3:** In case of no power supply with open gate and active Timer the control unit will restore its function, otherwise if during restoring of the power supply the TIMER is not activated it will be necessary to give a start impulse for the reclosing.

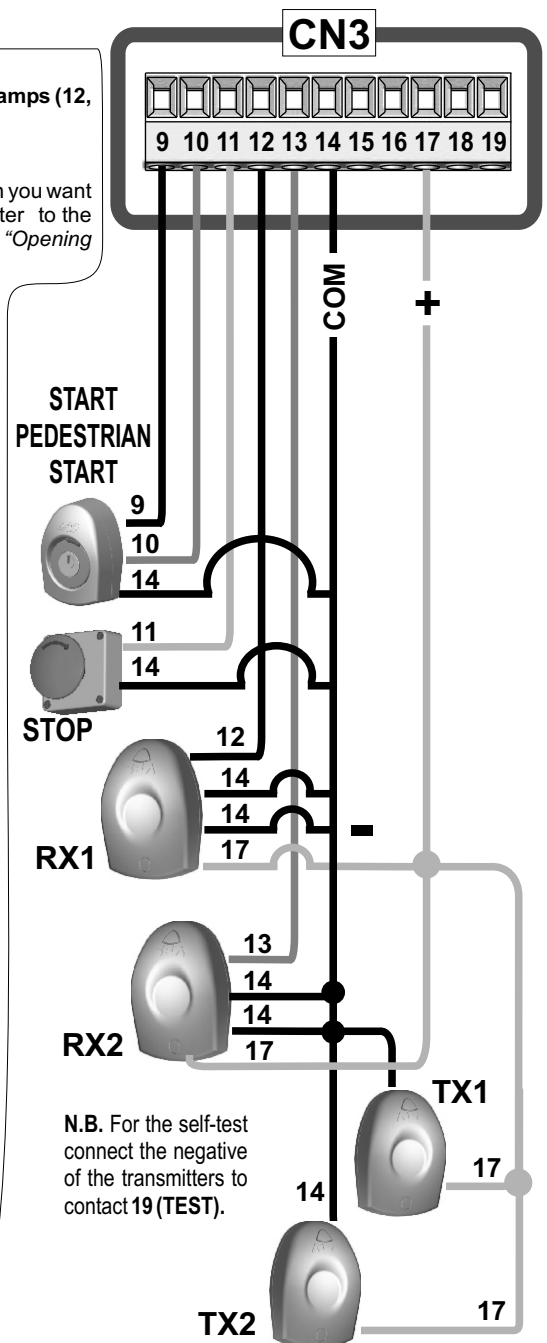

**N.B.** For the self-test connect the negative of the transmitters to contact 19 (TEST).

## SAFETY EDGE AND FLASHING LAMP

### SAFETY EDGE

It is possible to connect a safety edge (EDGE 1) between the contacts 22 and 23 of CN5.

The EDGE 1 contact, when squeezed, causes the partial inversion of the motion in both opening and closing.

**Note1:** Put a jumper between the not used N.C. Contacts. The EDG1 input can be set: only in closing, only in opening or in both directions.

**Note2:** It is possible to activate a balanced edge 8K2 through the on board display or through the Jolly programmer, in such case the edge contact will be controlled by a specific resistance value, detecting the possible involuntary short circuit of the device. In case of an imbalanced device a special alarm will show on the on board display or on the JOLLY programmer.

If you connect a wireless edge it is possible to make a self-test on the power supply of the receiver connecting the negative to the TEST input and selecting in the 96-EDGE AUTOTEST menu the item "Edge1".

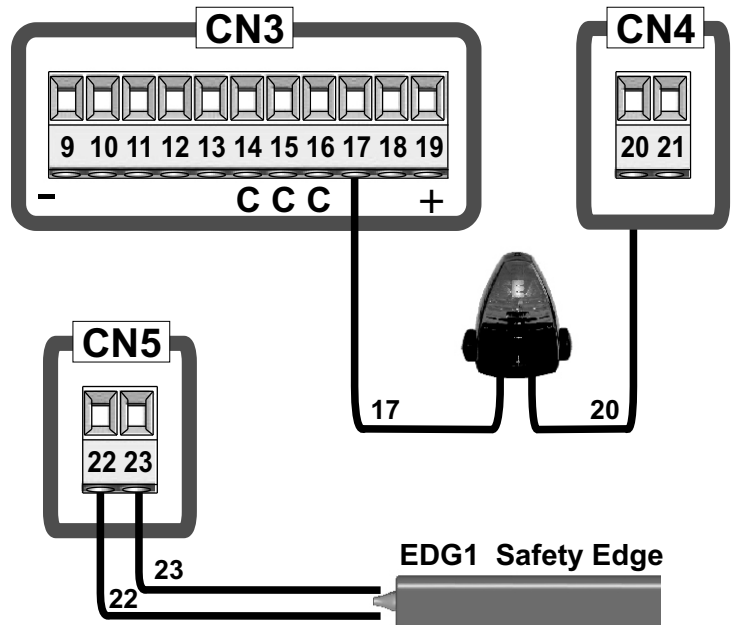

### 24V<sup>~</sup> Flashing light 4W Max (Control lamp)

The flashing light can be connected between the FLS and 24V<sup>~</sup>

It blinks once per second during opening and twice per second during closing, while it remains lit during pause.

Through the warning light it is also possible to identify alarm signals coming from the STOP, PHOTOCELL 1, PHOTOCELL2 and EDGE devices. Through the on board display or the Jolly programmer it is possible to activate the pre-flashing function and/or to modify the flashing light function choosing between fixed flashing, control lamp or Buzzer.

**The pre-flashing can be set from 0 to 5 s. or it is possible to have it only before closing.**

Also a warning lamp (Max 2W) can be connected between the 24V AUX output (CN3-18) and the negative (CN3-16) setting "Gate open warning light" in the 94-24V AUX menu.

## COURTESY LIGHT AND ELECTROLOCK

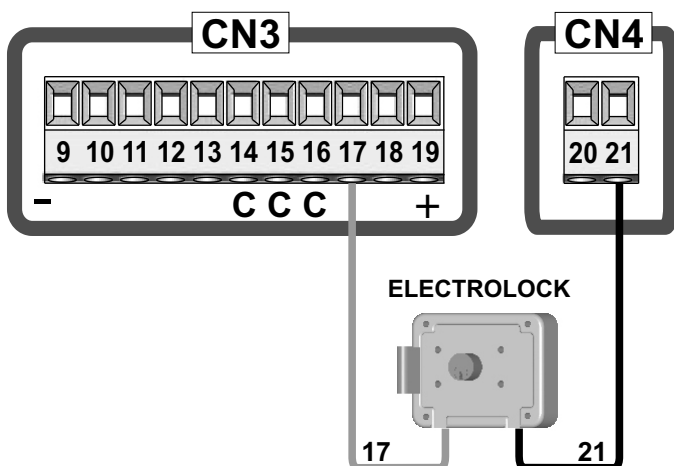
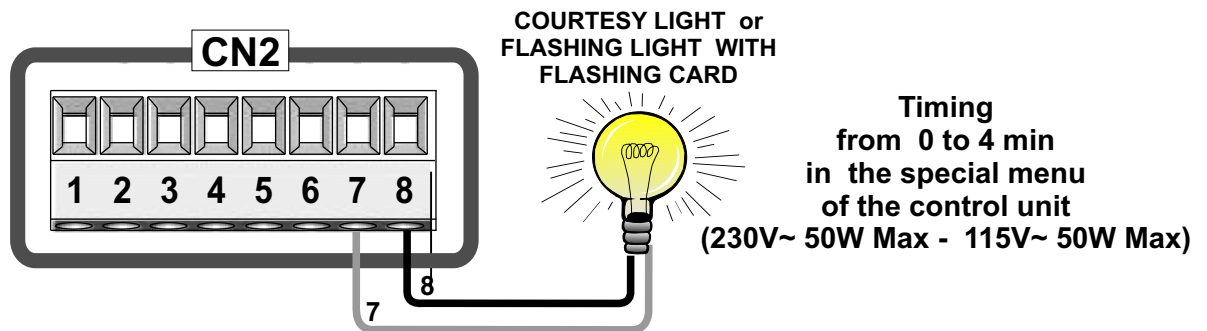

### ELECTROLOCK OUTPUT

A 12V<sup>~</sup> 15W max electrolock can be connected. Electrolock can be deactivated when not used for energy saving on the control unit. Electrolock release can be timed from 0 to 5 s.

The electrobrake can be set: only before opening, only before closing or in both directions.

# MOTORS CONNECTION, CAPACITY AND POWER SUPPLY

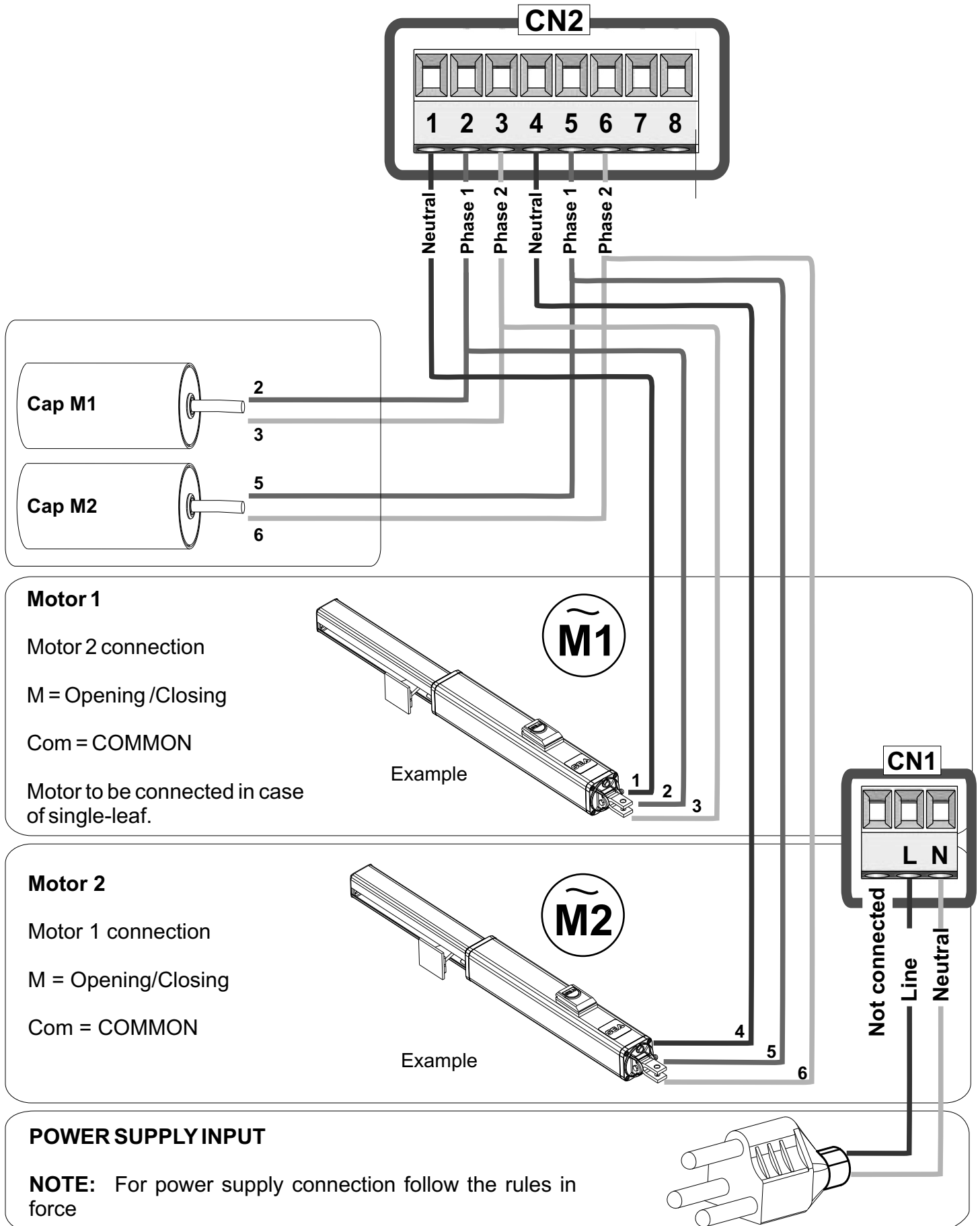

# TRAFFIC LIGHT CARD CONNECTION

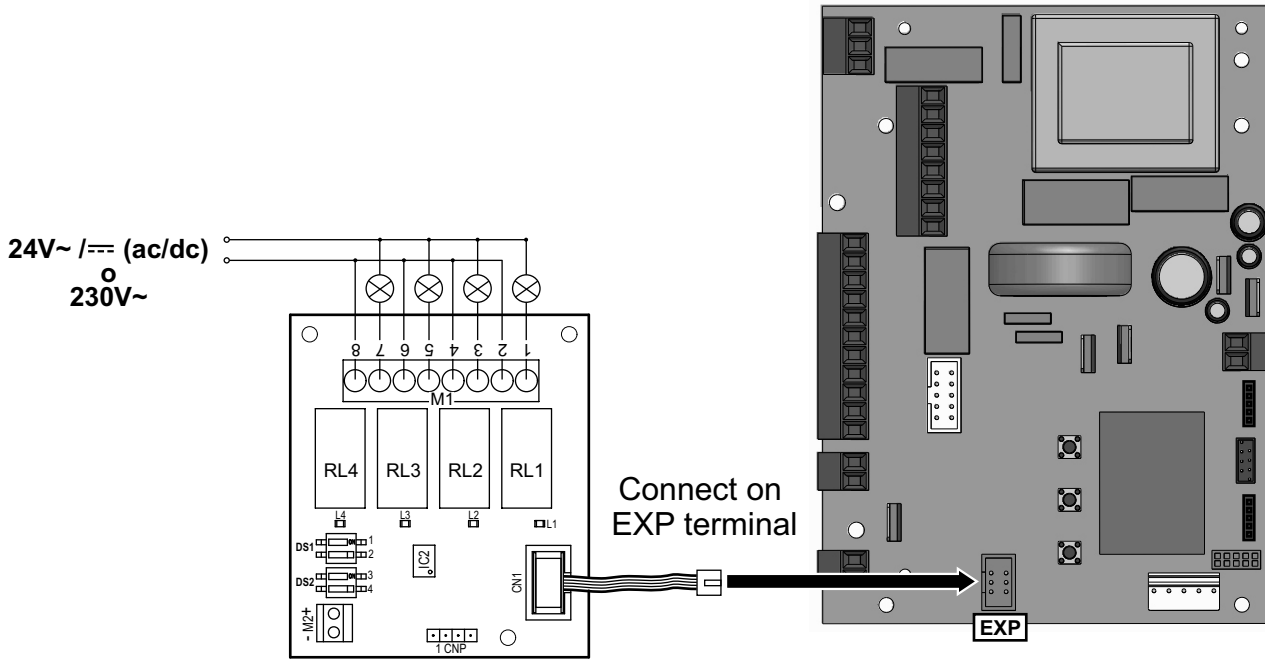

## ALARM DESCRIPTION

Signals	Kind of alarm	Solutions
FAILURE MOTOR	Motors current failure	Sure there are no short circuits on the motor or on the control unit.
FAILURE24	24V Power supply failure	Make sure there are no short circuits on the wiring or on the control unit and no overloads.
FAILURE24VAUX	AUX output voltage	Make sure there are no short circuits on wiring or control unit and no overload.
FAILURE NET	Power supply failure	Check the network or the F2 fuse
FAILURE SELF TEST	Self-test photocells failure	Check the photocells operation and / or connections on the control unit.
FAILURE LIMIT SWITCH	Limit switch activation failure	Check the operation of both limit switches and / or correspondence between movement direction of the motor and engaged limit switches.
FAILURE FLASHING LIGHT	Flashing lamp failure	Check connections and / or conditions of the lamp.
FAILURE ENCODER	Encoder failure	Encoder interface card is missing.
FAILURE POTENTIOMETER	Potentiometer failure	The message appears only if the potentiometer is ON and the potentiometer (LE) card is broken or not connected.

**Note 1:** If in the diagnostics shows "Max. cycles reached", do the maintenance and / or reset the number of cycles performed.

**Note2:** To exit from the error messages, press OK. If the error persists, make all required checks for the specific error and / or disconnect the device that generates the error to see if the error disappears.

At each opening and closing of the automation the flashing light will blink. It blinks once per second during opening and twice per second during closing, while it remains lit during pause.

It is possible to view the alarms also on the flashing light or on the control lamp, simply by observing the number of flashes emitted and verifying the reference in the table below:

Blinks	Cause of alarm
9	Motors failure
2	Photocell in closing
3	Photocell in opening
6	Collision in opening
4	Safety edge

Blinks	Cause of alarm
5	Stop
7	Max. Cycles reached

# TROUBLE SHOOTING

<b>Advices</b>		
<b>Make sure all Safeties are turned ON</b>		
<b>All N.C. contacts must have jumpers</b>		
Problem Found	Possibile Cause	Solutions
Motor doesn't respond to any START impulse	a.) Check the connected N.C. contacts  b.) Burnt fuse	a.) Check the connections or the jumpers on the connections of the safety edge or of the stop and of the photocell if connected  b.) Replace the burned fuse on the control unit
Gate doesn't move while the motor is running	a.) The motor is in the released position b.) There is an obstacle	a.) Re-lock the motor b.) Remove obstacle
Gate doesn't reach the complete Open / Closed position	a.) Wrong setting of the limit switches b.) Error on programming c.) Gate is stopped by an obstacle d.) Torque too low	a.) Set limit switches b.) Repeat programming c.) Remove obstacle d.) Increase torque parameter
The gate opens but doesn't close	a.) The contacts of the photocells are connected and open b.) The stop contact is connected and open c.) The edge contact is open d.) Ammeter alarm	a.) b.) c.) Check the jumpers or the signals indicated on the warning lamp d.) Check if the ammeter alarm has intervened and eventually increase the torque parameter.
The gate doesn't close automatically	a.) Pause time set to high b.) Control unit in semi-autom. logic	a.) Adjust pause time b.) Set the pause parameter on a different value from the OFF

## Page for both instaler and user

### MAINTENANCE

Considering the number of working cycles and the kind of gate, if the gate has changed the clutches and doesn't work it's necessary to periodically proceed, with **the learning times reprogramming on the electronic control unit**.  
Periodically clean the optical systems of the photocells.

### REPLACEMENTS

Any request for spare parts must be sent to:

**SEA S.p.A. - Zona Ind.le, 64020 S.ATTO - Teramo - Italia**

### SAFETY AND ENVIRONMENTAL COMPATIBILITY

Disposal of the packaging materials of products and/or circuits should take place in an approved disposal facility.



#### **REGULAR PRODUCT DISPOSAL (electric and electronic waste)**

(It's applicable in EU countries and in those ones provided with a differential waste collection)

The brand that you find on the product or on documentation signals that the product must not be disposed off together with other domestic waste at the end of life cycle. In order to avoid any possible environmental or health damage caused by irregular waste disposal, we recommend to separate this product from other forms of waste and to recycle it in a responsible way in order to provide the sustainable re-use of material resources. Domestic users are invited to contact the retailer where the product has been purchased or the local office in charge of all the information related to differential waste collection and recycling of this kind of product.

### STORING

<b>WAREHOUSING TEMPERATURES</b>			
$T_{min}$	$T_{Max}$	Dampness <sub>min</sub>	Dampness <sub>Max</sub>
- 20°C	+ 65°C	5% <i>Not condensing</i>	90% <i>Not condensing</i>

Materials handling must be made with appropriate vehicles..

### WARRANTY LIMITS

For the guarantee see the sales conditions on the official SEA price list.

*SEA reserves the right to make any required modification or change to the products and/or to this manual without any advanced notice obligation.*

## TERMS OF SALES

**EFFICACY OF THE FOLLOWING TERMS OF SALE:** the following general terms of sale shall be applied to all orders sent to SEAS.p.A. All sales made by SEA to all costumers are made under the prescription of this terms of sales which are integral part of sale contract and cancel and substitute all apposed clauses or specific negotiations present in order document received from the buyer.

**GENERAL NOTICE** The systems must be assembled exclusively with SEA components, unless specific agreements apply. Non-compliance with the applicable safety standards (European Standards EM12453 – EM 12445) and with good installation practice releases SEA from any responsibilities. SEA shall not be held responsible for any failure to execute a correct and safe installation under the above mentioned standards.

**1) PROPOSED ORDER** The proposed order shall be accepted only prior SEA approval of it. By signing the proposed order, the Buyer shall be bound to enter a purchase agreement, according to the specifications stated in the proposed order.

On the other hand, failure to notify the Buyer of said approval must not be construed as automatic acceptance on the part of SEA.

**2) PERIOD OF THE OFFER** The offer proposed by SEA or by its branch sales department shall be valid for 30 solar days, unless otherwise notified.

**3) PRICING** The prices in the proposed order are quoted from the Price List which is valid on the date the order was issued. The discounts granted by the branch sales department of SEA shall apply only prior to acceptance on the part of SEA. The prices are for merchandise delivered ex-works from the SEA establishment in Teramo, not including VAT and special packaging. SEA reserves the right to change at any time this price list, providing timely notice to the sales network. The special sales conditions with extra discount on quantity basis (Qx, Qx1, Qx2, Qx3 formula) is reserved to official distributors under SEA management written agreement.

**4) PAYMENTS** The accepted forms of payment are each time notified or approved by SEA. The interest rate on delay in payment shall be 1.5% every month but anyway shall not be higher than the max. interest rate legally permitted.

**5) DELIVERY** Delivery shall take place, approximately and not peremptorily, within 30 working days from the date of receipt of the order, unless otherwise notified. Transport of the goods sold shall be at Buyer's cost and risk. SEA shall not bear the costs of delivery giving the goods to the carrier, as chosen either by SEA or by the Buyer. Any loss and/or damage of the goods during transport, are at Buyer's cost.

**6) COMPLAINTS** Any complaints and/or claims shall be sent to SEA within 8 solar days from receipt of the goods, proved by adequate supporting documents as to their truthfulness.

**7) SUPPLY** The concerning order will be accepted by SEA without any engagement and subordinately to the possibility to get it's supplies of raw material which is necessary for the production; Eventual completely or partially unsuccessful executions cannot be reason for complains or reservations for damage. SEA supply is strictly limited to the goods of its manufacturing, not including assembly, installation and testing. SEA, therefore, disclaims any responsibility for damage deriving, also to third parties, from non-compliance of safety standards and good practice during installation and use of the purchased products.

**8) WARRANTY** The standard warranty period is 12 months. This warranty time can be extended by means of expedition of the warranty coupon as follows:

**SILVER:** The mechanical components of the operators belonging to this line are guaranteed for 24 months from the date of manufacturing written on the operator.

**GOLD:** The mechanical components of the operators belonging to this line are guaranteed for 36 months from the date of manufacturing written on the operator.

**PLATINUM:** The mechanical components of the operators belonging to this line are guaranteed for 36 months from the date of manufacturing written on the operator. The base warranty (36 months) will be extended for further 24 months (up to a total of 60 months) when it is acquired the certificate of warranty which will be filled in and sent to SEA S.p.A. The electronic devices and the systems of command are guaranteed for 24 months from the date of manufacturing. In case of defective product, SEA undertakes to replace free of charge or to repair the goods provided that they are returned to SEA repair centre. The definition of warranty status is by unquestionable assessment of SEA. The replaced parts shall remain propriety of SEA. Binding upon the parties, the material held in warranty by the Buyer, must be sent back to SEA repair centre with fees prepaid, and shall be dispatched by SEA with carriage forward. The warranty shall not cover any required labour activities.

The recognized defects, whatever their nature, shall not produce any responsibility and/or damage claim on the part of the Buyer against SEA. The guarantee is in no case recognized if changes are made to the goods, or in the case of improper use, or in the case of tampering or improper assembly, or if the label affixed by the manufacturer has been removed including the SEA registered trademark No. 804888. Furthermore, the warranty shall not apply if SEA products are partly or completely coupled with non-original mechanical and/or electronic components, and in particular, without a specific relevant authorization, and if the Buyer is not making regular payments. The warranty shall not cover damage caused by transport, expendable material, faults due to non-conformity with performance specifications of the products shown in the price list. No indemnification is granted during repairing and/or replacing of the goods in warranty. SEA disclaims any responsibility for damage to objects and persons deriving from non-compliance with safety standards, installation instructions or use of sold goods. The repair of products under warranty and out of warranty is subject to compliance with the procedures notified by SEA.

**9) RESERVED DOMAIN** A clause of reserved domain applies to the sold goods; SEA shall decide autonomously whether to make use of it or not, whereby the Buyer purchases propriety of the goods only after full payment of the latter.

**10) COMPETENT COURT OF LAW** In case of disputes arising from the application of the agreement, the competent court of law is the tribunal of Teramo. SEA reserves the faculty to make technical changes to improve its own products, which are not in this price list at any moment and without notice. SEA declines any responsibility due to possible mistakes contained inside the present price list caused by printing and/or copying. The present price list cancels and substitutes the previous ones. The Buyer, according to the law No. 196/2003 (privacy code) consents to put his personal data, deriving from the present contract, in SEA archives and electronic files, and he also gives his consent to their treatment for commercial and administrative purposes.

**Industrial ownership rights:** once the Buyer has recognized that SEA has the exclusive legal ownership of the registered SEA brand num.804888 affixed on product labels and / or on manuals and / or on any other documentation, he will commit himself to use it in a way which does not reduce the value of these rights, he won't also remove, replace or modify brands or any other particularity from the products. Any kind of replication or use of SEA brand is forbidden as well as of any particularity on the products, unless preventive and expressed authorization by SEA.

**In accomplishment with art. 1341 of the Italian Civil Law it will be approved expressly clauses under numbers:**

**4) PAYMENTS - 8) GUARANTEE - 10) COMPETENT COURT OF LAW**

### **Italiano** AVVERTENZE GENERALI PER INSTALLATORE E UTENTE

1. Leggere attentamente le **Istruzioni di Montaggio** e le **Avvertenze Generali** prima di iniziare l'installazione del prodotto. Conservare la documentazione per consultazioni future
2. Non disperdere nell'ambiente i materiali di imballaggio del prodotto e/o circuiti
3. Questo prodotto è stato progettato e costruito esclusivamente per l'utilizzo indicato in questa documentazione. Qualsiasi altro utilizzo non espressamente indicato potrebbe pregiudicare l'integrità del prodotto e/o rappresentare fonte di pericolo. L'uso improprio è anche causa di cessazione della garanzia. La SEA S.p.A. declina qualsiasi responsabilità derivata dall'uso improprio o diverso da quello per cui l'automatismo è destinato.
4. I prodotti SEA sono conformi alle Direttive: Macchine (2006/42/CE e successive modifiche), Bassa Tensione (2006/95/CE e successive modifiche), Compatibilità Elettromagnetica (2004/108/CE e successive modifiche). L'installazione deve essere effettuata nell'osservanza delle norme EN 12453 e EN 12445.
5. Non installare l'apparecchio in atmosfera esplosiva.
6. SEA S.p.A. non è responsabile dell'inosservanza della Buona Tecnica nella costruzione delle chiusure da motorizzare, nonché delle deformazioni che dovessero verificarsi durante l'uso.
7. Prima di effettuare qualsiasi intervento sull'impianto, togliere l'alimentazione elettrica e scollegare le batterie. Verificare che l'impianto di terra sia realizzato a regola d'arte e collegarvi le parti metalliche della chiusura.
8. Per ogni impianto SEA S.p.A. consiglia l'utilizzo di almeno una segnalazione luminosa nonché di un cartello di segnalazione fissato adeguatamente sulla struttura dell'infisso.
9. SEA S.p.A. declina ogni responsabilità ai fini della sicurezza e del buon funzionamento della automazione, in caso vengano utilizzati componenti di altri produttori.
10. Per la manutenzione utilizzare esclusivamente parti originali SEA.
11. Non eseguire alcuna modifica sui componenti dell'automazione.
12. L'installatore deve fornire tutte le informazioni relative al funzionamento manuale del sistema in caso di emergenza e consegnare all'Utente utilizzatore dell'impianto il libretto d'avvertenze allegato al prodotto.
13. Non permettere ai bambini o persone di sostare nelle vicinanze del prodotto durante il funzionamento. L'applicazione non può essere utilizzata da bambini, da persone con ridotte capacità fisiche, mentali, sensoriali o da persone prive di esperienza o del necessario addestramento. Tenere inoltre fuori dalla portata dei bambini radiocomandi o qualsiasi altro datore di impulso, per evitare che l'automazione possa essere azionata involontariamente.
14. Il transito tra le ante deve avvenire solo a cancello completamente aperto.
15. Tutti gli interventi di manutenzione, riparazione o verifiche periodiche devono essere eseguiti da personale professionalmente qualificato. L'utente deve astenersi da qualsiasi tentativo di riparazione o d'intervento e deve rivolgersi esclusivamente a personale qualificato SEA. L'utente può eseguire solo la manovra manuale.
16. La lunghezza massima dei cavi di alimentazione fra centrale e motori non deve essere superiore a 10 m. Utilizzare cavi con sezione 2.5 mm<sup>2</sup>. Utilizzare cablaggi con cavi in doppio isolamento (cavi con guaina) nelle immediate vicinanze dei morsetti specie per il cavo di alimentazione (230V). Inoltre è necessario mantenere adeguatamente lontani (almeno 2.5 mm in aria) i conduttori in bassa tensione (230V) dai conduttori in bassissima tensione di sicurezza (SELV) oppure utilizzare un'adeguata guaina che fornisca un isolamento supplementare avente uno spessore di almeno 1 mm.

### **English** GENERAL NOTICE FOR THE INSTALLER AND THE USER

1. Read carefully these **Instructions** before beginning to install the product. Store these instructions for future reference
2. Don't waste product packaging materials and /or circuits.
3. This product was designed and built strictly for the use indicated in this documentation. Any other use, not expressly indicated here, could compromise the good condition/operation of the product and/or be a source of danger. SEA S.p.A. declines all liability caused by improper use or different use in respect to the intended one.
4. The mechanical parts must be comply with Directives: Machine Regulation 2006/42/CE and following adjustments), Low Tension (2006/95/CE), electromagnetic Consistency (2004/108/CE) Installation must be done respecting Directives: EN12453 and EN12445.
5. Do not install the equipment in an explosive atmosphere.
6. SEA S.p.A. is not responsible for failure to observe Good Techniques in the construction of the locking elements to motorize, or for any deformation that may occur during use.
7. Before attempting any job on the system, cut out electrical power and disconnect the batteries. Be sure that the earthing system is perfectly constructed, and connect it metal parts of the lock.
8. Use of the indicator-light is recommended for every system, as well as a warning sign well-fixed to the frame structure.
9. SEA S.p.A. declines all liability as concerns the automated system's security and efficiency, if components used, are not produced by SEAS.p.A..
10. For maintenance, strictly use original parts by SEA.
11. Do not modify in any way the components of the automated system.
12. The installer shall supply all information concerning system's manual functioning in case of emergency, and shall hand over to the user the warnings handbook supplied with the product.
13. Do not allow children or adults to stay near the product while it is operating. The application cannot be used by children, by people with reduced physical, mental or sensorial capacity, or by people without experience or necessary training. Keep remote controls or other pulse generators away from children, to prevent involuntary activation of the system.
14. Transit through the leaves is allowed only when the gate is fully open.
15. The User must not attempt to repair or to take direct action on the system and must solely contact qualified SEA personnel or SEA service centers. User can apply only the manual function of emergency.
16. The power cables maximum length between the central engine and motors should not be greater than 10 m. Use cables with 2,5 mm<sup>2</sup> section. Use double insulation cable (cable sheath) to the immediate vicinity of the terminals, in particular for the 230V cable. Keep an adequate distance (at least 2.5 mm in air), between the conductors in low voltage (230V) and the conductors in low voltage safety (SELV) or use an appropriate sheath that provides extra insulation having a thickness of 1 mm.

### **Français** CONSIGNES POUR L'INSTALLATEUR ET L'UTILISATEUR

1. Lire attentivement les **instructions** avant d'installer le produit. Conserver les instructions en cas de besoin.
2. Ne pas dispenser dans l'environnement le matériel d'emballage du produit et/ou des circuits.
3. Ce produit a été conçu et construit exclusivement pour l'usage indiqué dans cette documentation. Toute autre utilisation non expressément indiquée pourrait compromettre l'intégrité du produit et / ou être une source de danger. L'utilisation inappropriée est également cause d'annulation de la garantie. SEA S.p.A. N'assume aucune responsabilité pour une utilisation inappropriée ou une utilisation autre que celle pour laquelle l'automatisme est destiné.
4. Les composants doivent répondre aux prescriptions des Normes: Machines (2006/42/CE et successifs changements); Basse Tension (2006/95/CE et successifs changements); EMC (2004/108/CE et successifs changements). L'installation doit être effectuée conformément aux Normes EN 12453 et EN 12445.
5. Ne pas installer l'appareil dans une atmosphère explosive.
6. SEA S.p.A. n'est pas responsable du non-respect de la Bonne Technique de construction des fermetures à motoriser, ni des déformations qui pourraient intervenir lors de l'utilisation.
7. Couper l'alimentation électrique et déconnecter la batterie avant toute intervention sur l'installation. Vérifier que la mise à terre est réalisée selon les règles de l'art et y connecter les pièces métalliques de la fermeture.
8. On recommande que toute installation soit doté au moins d'une signalisation lumineuse, d'un panneau de signalisation fixé, de manière appropriée, sur la structure de la fermeture.
9. SEA S.p.A. décline toute responsabilité quant à la sécurité et au bon fonctionnement de l'automatisme si les composants utilisés dans l'installation n'appartiennent pas à la production SEA.



10. Utiliser exclusivement, pour l'entretien, des pièces SEA originales.
11. Ne jamais modifier les composants d'automatisme.
12. L'installateur doit fournir toutes les informations relatives au fonctionnement manuel du système en cas d'urgence et remettre à l'Usager qui utilise l'installation les "Instructions pour l'Usager" fournies avec le produit.
13. Interdire aux enfants ou aux tiers de stationner près du produit durant le fonctionnement. Ne pas permettre aux enfants, aux personnes ayant des capacités physiques, mentales et sensorielles limitées ou dépourvues de l'expérience ou de la formation nécessaires d'utiliser l'application en question. Eloigner de la portée des enfants les radiocommandes ou tout autre générateur d'impulsions, pour éviter tout actionnement involontaire de l'automatisme.
14. Le transit entre les vantaux ne doit avoir lieu que lorsque le portail est complètement ouvert.
15. L'utilisateur doit s'abstenir de toute tentative de réparation ou d'intervention et doit s'adresser uniquement et exclusivement au personnel qualifié SEA ou aux centres d'assistance SEA. L'utilisateur doit garder la documentation de la réparation. L'utilisateur peut exécuter seulement la manoeuvre manuel.
16. La longueur maximum des câbles d'alimentation entre la carte et les moteurs ne devrait pas être supérieure à 10 m. Utilisez des câbles avec une section de 2,5 mm<sup>2</sup>. Utilisez des câblage avec câble à double isolation (avec gaine) jusqu'à proximité immédiate des terminaux, en particulier pour le câble d'alimentation (230V). Il est également nécessaire de maintenir une distance suffisante (au moins 2,5 mm dans l'air), entre les conducteurs en basse tension (230V) et les conducteurs de très basse tension de sécurité (SELV) ou utiliser une gaine ayant une épaisseur d'au moins 1 mm, qui fournisse une isolation supplémentaire.

### **Español** ADVERTENCIAS GENERALES PARA INSTALADORES Y USUARIOS

- 1 Leer las **instrucciones de instalación** antes de comenzar la instalación. Mantenga las instrucciones para consultas futura
2. No desperdiciar en el ambiente los materiales de embalaje del producto o del circuito
3. Este producto fue diseñado y construido exclusivamente para el uso especificado en esta documentación. Cualquier otro uso no expresamente indicado puede afectar la integridad del producto y ser una fuente de peligro. El uso inadecuado es también causa de anulación de la garantía. SEA S.p.A. se exime de toda responsabilidad causadas por uso inapropiado o diferente de aquel para el que el sistema automatizado fue producido.
4. Los productos cumplen con la Directiva: Maquinas (2006/42/CE y siguientes modificaciones), Baja Tension (2006/95/CE, y siguientes modificaciones), Compatibilidad Electromagnética (2004/108/CE modificada). La instalación debe ser llevada a cabo de conformidad a las normas EN 12453 y EN 12445.
5. No instalar el dispositivo en una atmósfera explosiva.
6. SEAS.p.A. no es responsable del incumplimiento de la mano de obra en la construcción de la cancela a automatizar y tampoco de las deformaciones que puedan producirse durante el uso.
7. Antes de realizar cualquier operación apagar la fuente de alimentación y desconectar las baterías. Comprobar que el sistema de puesta a tierra sea diseñado de una manera profesional y conectar las partes metálicas del cierre.
8. Para cada instalación se recomienda utilizar como mínimo una luz parpadeante y una señal de alarma conectada a la estructura del marco.
9. SEAS.p.A. no acepta responsabilidad por la seguridad y el buen funcionamiento de la automatización en caso de utilización de componentes no producidos por SEA.
10. Para el mantenimiento utilizar únicamente piezas originales SEAS.p.A..
11. No modificar los componentes del sistema automatizado.
12. El instalador debe proporcionar toda la información relativa al funcionamiento manual del sistema en caso de emergencia y darle al usuario el folleto de adjunto al producto.
13. No permita que niños o adultos permanecen cerca del producto durante la la operación. La aplicación no puede ser utilizada por niños, personas con movilidad reducida de tipo físico, mental, sensorial o igual por personas sin experiencia o formación necesaria. Tener los radiomandos fuera del alcance de niños así como cualquier otro generador de impulsos radio para evitar que el automación pueda ser accionada accidentalmente.
14. El tránsito a través de las hojas sólo se permite cuando la puerta está completamente abierta.
15. Todo el mantenimiento, reparación o controles deberán ser realizados por personal cualificado. Evitar cualquier intento a reparar o ajustar. En caso de necesidad comunicarse con un personal SEA calificado. Sólo se puede realizar la operación manual.
16. La longitud máxima de los cables de alimentación entre motor y central no debe ser superior a 10 metros. Utilizar cables con 2,5 mm<sup>2</sup>. Utilizar cables con doble aislamiento (cables con vaina) hasta muy cerca de los bornes, especialmente por el cable de alimentación (230V). Además es necesario mantener adecuadamente distanciados (por lo menos 2,5 mm en aire) los conductores de baja tensión (230V) y los conductores de baja tensión de seguridad (SELV) o utilizar una vaina adecuada que proporcione aislamiento adicional con un espesor mínimo de 1 mm.



**Dichiarazione di conformità**  
**Declaration of Conformity**

La SEA S.p.A. dichiara sotto la propria responsabilità e, se applicabile, del suo rappresentante autorizzato che il prodotto:  
*SEA S.p.A. declares under its proper responsibility and, if applicable, under the responsibility of its authorised representative that the product:*

<b>Descrizione / Description</b>	<b>Modello / Model</b>	<b>Marca / Trademark</b>
SWING 2 DG R2F (e tutti i suoi derivati)	23021096	SEA
<i>SWING 2 DG R2F (and all its by-products)</i>	<i>23021096</i>	<i>SEA</i>

è costruito per essere incorporato in una macchina o per essere assemblato con altri macchinari per costruire una macchina ai sensi della Direttiva 2006/42/CE:

*is built to be integrated into a machine or to be assembled with other machinery to create a machine under the provisions of Directive 2006/42/CE:*

- Direttiva 2006/42/CE Direttiva macchine (allegato I)  
*Directive 2006/42/CE Machinery Directive (annex I)*

- Direttiva 2004/108/CE Direttiva compatibilità elettromagnetica  
*Directive 2004/108/CE Electromagnetic compatibility*

- CEI EN55014-1 Emissioni condotte e radiate  
*IEC EN55014-1 Conducted and radiated emissions*
- CEI EN55014-2 Prove di immunità  
*IEC EN55014-2 Magnetic field immunity*

- Direttiva 2006/95/CE - Direttiva Bassa Tensione  
*Directive 2006/95/CE - Low voltage Directive*

- CEI EN60335-1:2008 Sicurezza degli apparecchi elettrici d'uso domestico e similare (Requisiti Generali).  
*IEC EN60335-1:2008 Household and similar electrical appliances - Safety - Part one: general requirements.*

L'apparecchiatura usando gli specifici accessori di sicurezza certificati e rispettando tutti i vincoli normativi della macchina nel suo complesso (apparecchiatura, azionamento e struttura) può permettere un'installazione secondo le Norme:

*The control unit, using the specific safety certified accessories and respecting all the regulatory constraints of the machine as a whole (control unit, operation and structure) may allow an installation according to the following Standards:*

- EN 12453 2000
- EN 12445 2002
- EN 60335-1-103:2006+A1:2011

**COSTRUTTORE o RAPPRESENTANTE AUTORIZZATO:**  
**MANUFACTURER or AUTHORISED REPRESENTATIVE:**

SEA S.p.A.  
DIREZIONE E STABILIMENTO:  
Zona industriale 64020 S.ATTO Teramo - (ITALY)  
Tel. +39 0861 588341 r.a. Fax +39 0861 588344  
[Http://www.seateam.com](http://www.seateam.com)

(Luogo, data di emissione)  
*(Place, date of issue)*  
Teramo, 23/06/2015

L'Amministratore  
*The Administrator*  
Ennio Di Saverio



**SEA**<sup>®</sup>  
electronic opening system

Questo articolo è stato prodotto seguendo rigide procedure di lavorazione ed è stato testato singolarmente al fine di garantire i più alti livelli qualitativi e la vostra soddisfazione. Vi ringraziamo per aver scelto SEA.

This item has been produced following strict production procedures and has been singularly tested for the highest quality levels and for your complete satisfaction. Thanks for choosing SEA.

Cet article a été produit suivant des procédures d'usage strictes et il a singulièrement été testé afin de garantir les plus hauts niveaux de qualité pour votre satisfaction. Nous vous remercions d'avoir choisi SEA.

Este artículo ha sido producido siguiendo rigidos procedimientos de elaboración y ha sido probando singolarmente a fin de garantizar los mas altos niveles de calidad y vuestra satisfaccion. Le agradecemos por haber escogito SEA.



**SEA<sup>®</sup>**

Sistemi Elettronici  
di Apertura Porte e Cancelli  
International registered trademark n. 804888



**SEA S.p.A.**  
**Zona industriale 64020 S.ATTO Teramo - (ITALY)**  
**Tel. +39 0861 588341 r.a. Fax +39 0861 588344**

**[www.seateam.com](http://www.seateam.com)**

**[seacom@seateam.com](mailto:seacom@seateam.com)**