



DE Original Montageanleitung LIFTer Montagelaufwagen
 EN Translation of the original installation manual LIFTer Installation carriage
 FR Traduction de la notice de montage originale LIFTer Chariot de montage
 IT Traduzione delle istruzioni di montaggio originali LIFTer Slitta motore
 ES Traducción de las instrucciones de montaje originales LIFTer Carro de montaje

Art.-Nr. S10941-00001

SOMMER Antriebs- und Funktechnik GmbH

Hans-Böckler-Straße 21–27
 D-73230 Kirchheim/Teck
 Germany

+49 (0) 900 1800-150

• 0,14 €/min aus dem deutschen Festnetz.
 Mobilfunkpreise abweichend.

Contact info:

Coordonnées:

Informazioni di contatto:

Información de contacto:

info@sommer.eu
 www.sommer.eu

© Copyright 2018

Alle Rechte vorbehalten.

All rights reserved.

Tous droits réservés.

Tutti i diritti riservati.

Reservados todos los derechos.

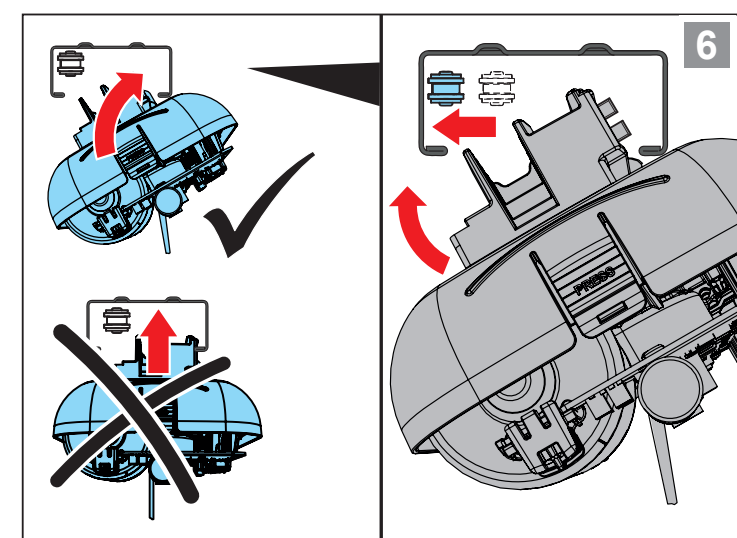
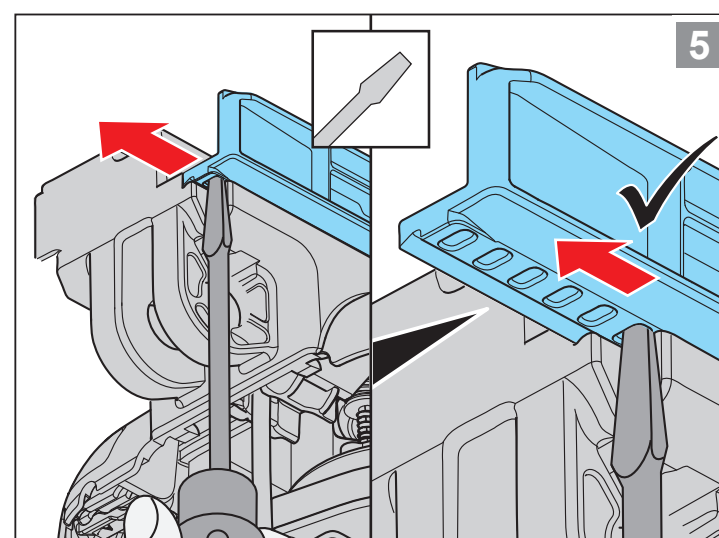
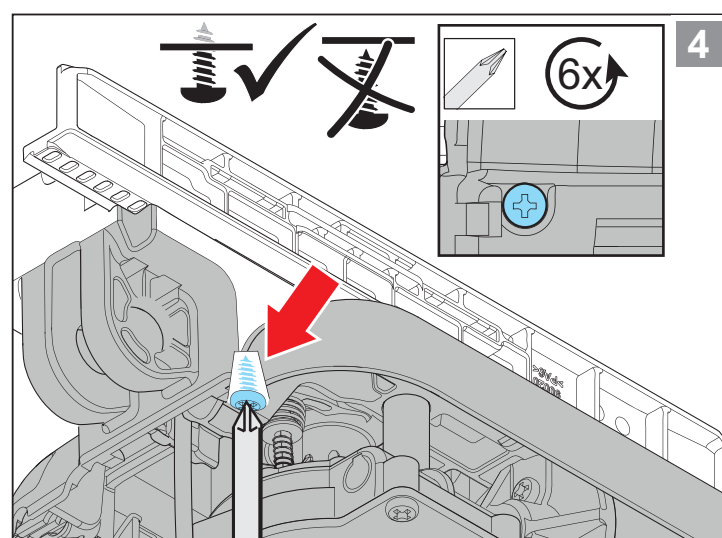
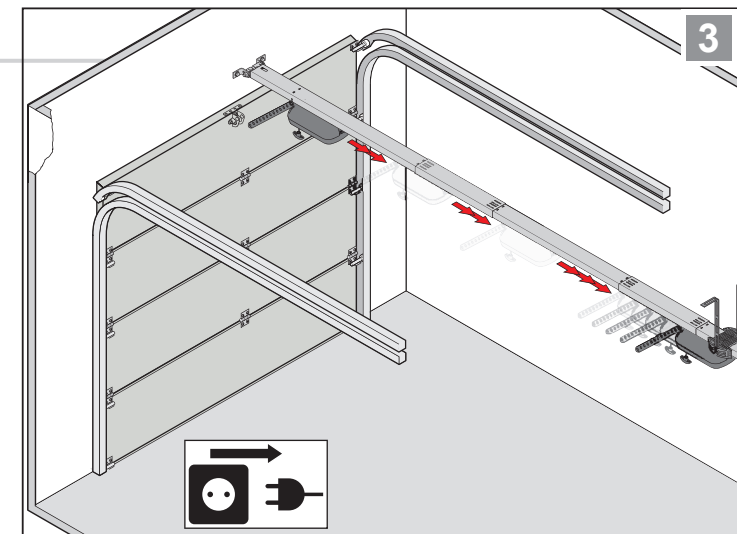
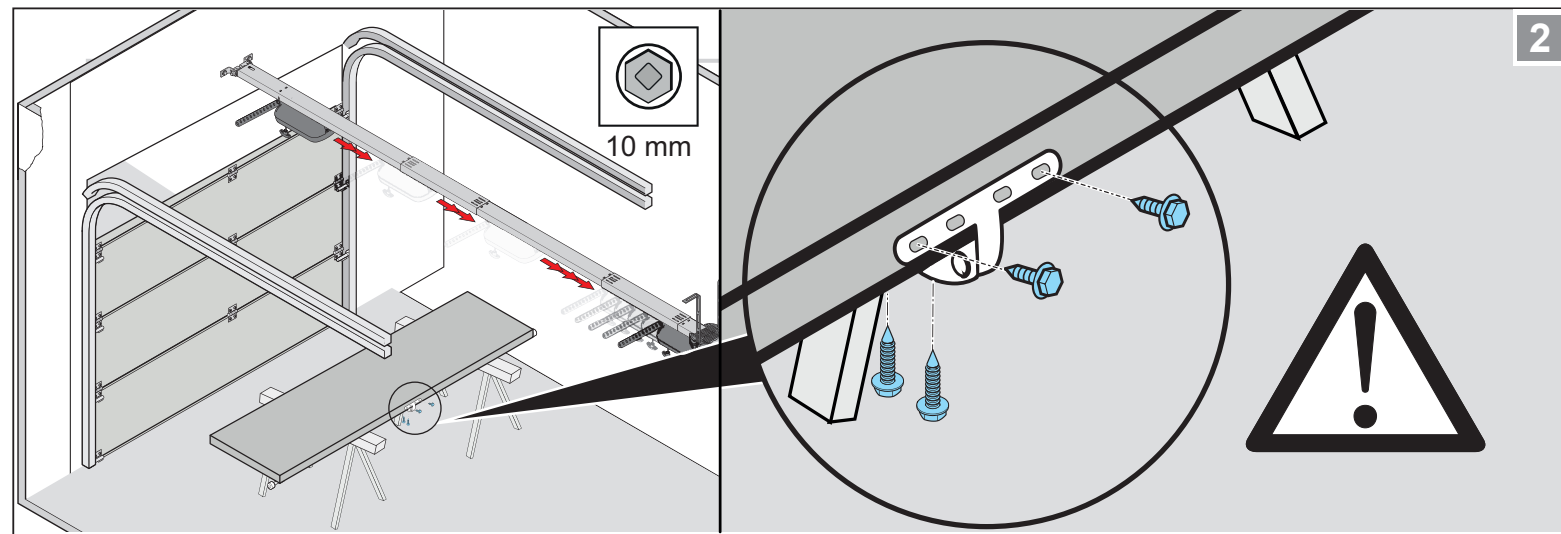
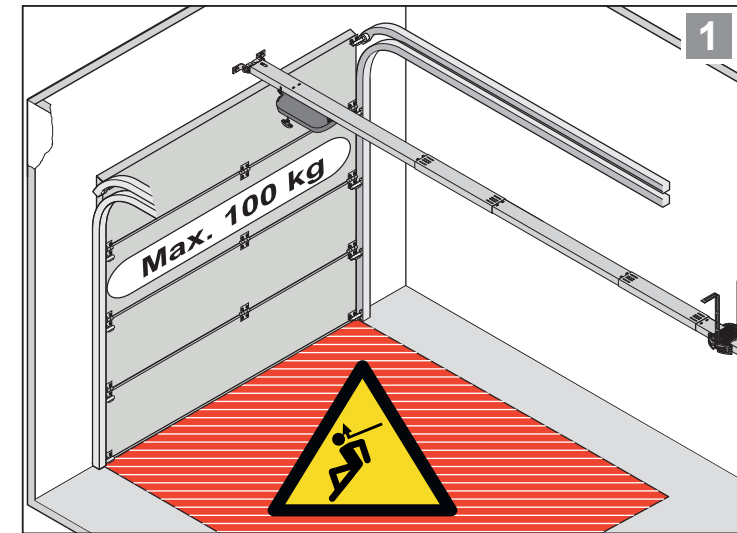
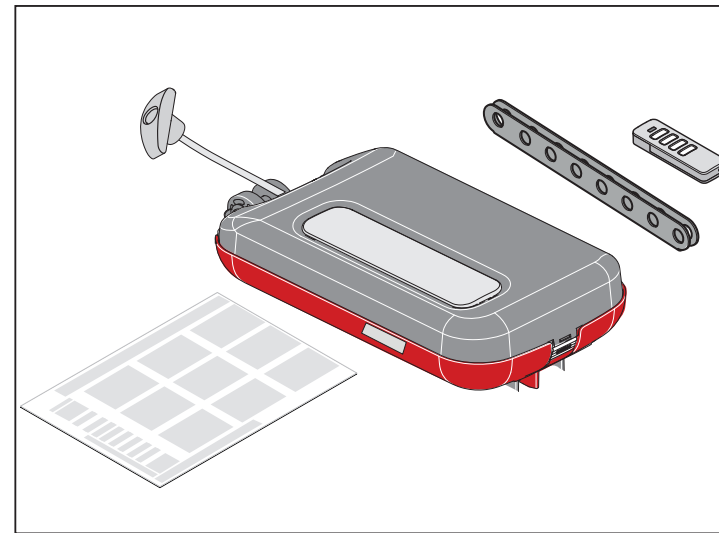
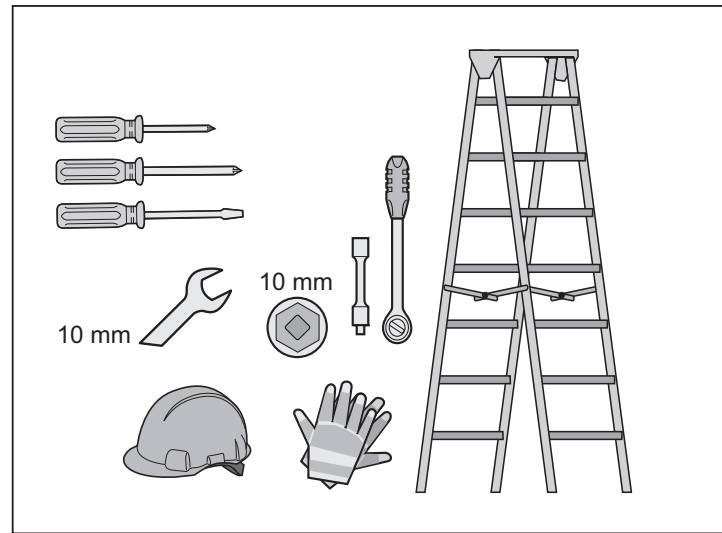

Art.-Nr. S11128-00000_372018_0-DRE_Rev-C_DE



DE Original Montageanleitung LIFTer Montagelaufwagen
 EN Translation of the original installation manual LIFTer Installation carriage
 FR Traduction de la notice de montage originale LIFTer Chariot de montage
 IT Traduzione delle istruzioni di montaggio originali LIFTer Slitta motore
 ES Traducción de las instrucciones de montaje originales LIFTer Carro de montaje

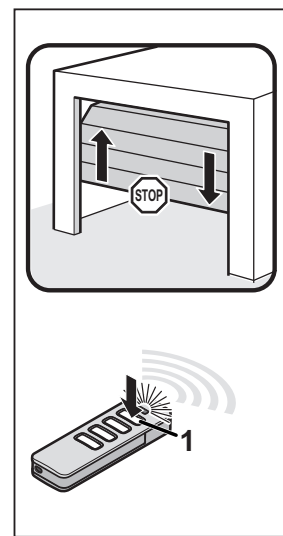
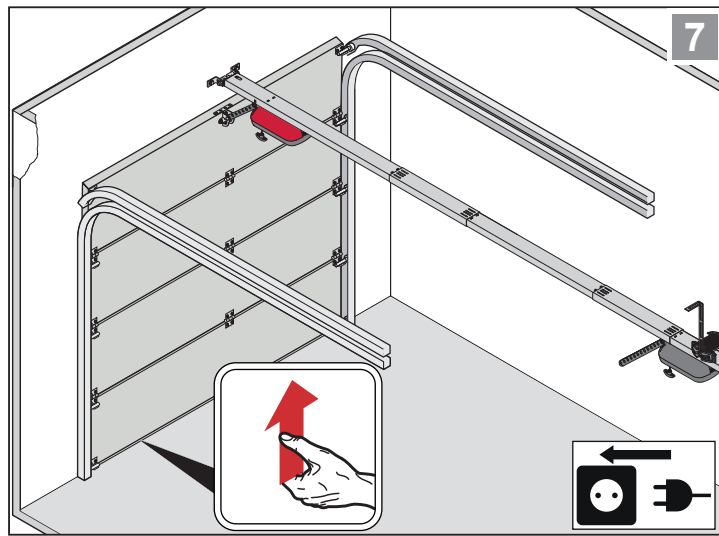

8 Durch Funkkanal 2 kann der Kurzschluß des Relais aufgehoben werden. (Notfalllösung um bei einer Verklebung den Laufwagen sicher zu entlasten.)
 The relay short-circuit can be cancelled via radio channel 2. (Emergency solution to reliably relieve the load on the carriage if jamming occurs.)
 Le canal radio 2 permet d'éliminer le court-circuit du relais. (Solution de secours permettant de décharger le chariot en toute sécurité en cas de blocage.)
 Attraverso il canale radio 2 è possibile interrompere il cortocircuito del relé. (Soluzione di emergenza per sbloccare in sicurezza la slitta motore in caso di bloccaggio.)
 A través del canal de radio 2 puede subsanarse el cortocircuito del relé. (Solución de emergencia para descargar el carro de forma segura en caso de enclavamiento.)

