

L8542058
Rev. 07/04/00

BENINCA®

CENTRALE DI COMANDO

CONTROL UNIT

STEUEREINHEIT

CENTRALE DE COMMANDE

CENTRAL DE MANDO

CENTRALKA STEROWANIA

SA.02 KIT

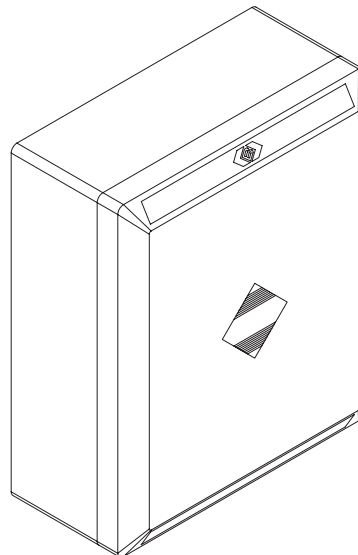

Libro istruzioni
Operating instructions
Betriebsanleitung
Livret d'instructions
Manual de instrucciones
Książeczka z instrukcjami



UNIONE NAZIONALE COSTRUTTORI
AUTOMATISMI PER CANCELLI, PORTE,
SERRANDE ED AFFINI

Dichiarazione CE di conformità
EC declaration of conformity
EG-Konformitätserklärung

Déclaration CE de conformité
Declaracion CE de conformidad
Deklaracja UE o zgodności

Con la presente dichiariamo che il nostro prodotto
We hereby declare that our product
Hiermit erklaren wir, dass unser Produkt
Nous déclarons par la présente que notre produit
Por la presente declaramos que nuestro producto
Niniejszym oświadczamy że nasz produkt

SA.02

è conforme alle seguenti disposizioni pertinenti:
complies with the following relevant provisions:
folgenden einschlagigen Bestimmungen entspricht:
correspond aux dispositions pertinentes suivantes:
satisface las disposiciones pertinentes siguientes:
zgodny jest z poniżej wyszczególnionymi rozporządzeniami:

Direttiva sulla compatibilità elettromagnetica (89/336/
CCE, 93/68/CEE)
EMC guidelines (89/336/EEC, 93/68/EEC)
EMV-Richtlinie (89/336/EWG, 93/68/EWG)
Directive EMV (89/336/CCE, 93/68/CEE) (Compatibilité
électromagnétique)
Reglamento de compatibilidad electromagnética (89/336/
MCE, 93/68/MCE)
Wytyczna odnośnie zdolności współdziałania elektromagne-
tycznego (89/336/EWG, 93/68/EWG)

Direttiva sulla bassa tensione (73/23/CEE, 93/68/CEE)
Low voltage guidelines (73/23/EEC, 93/68/EEC)
Tiefe Spannung Richtlinie (73/23/EWG, 93/68/EWG)
Directive bas voltage (73/23/CEE, 93/68/CEE)
Reglamento de bajo Voltaje (73/23/MCE, 93/68/MCE)
Wytyczna odnośnie niskiego napięcia (73/23/EWG, 93/
68/EWG)

Norme armonizzate applicate in particolare:
Applied harmonized standards, in particular:
Angewendete harmonisierte Normen, insbesondere:
Normes harmonisées utilisées, notamment:
Normas armonizadas utilizadas particularmente:
Normy standard najczęściej stosowane:

Norme armonizzate applicate in particolare:
Applied harmonized standards, in particular:
Angewendete harmonisierte Normen, insbesondere:
Normes harmonisées utilisées, notamment:
Normas armonizadas utilizadas particularmente:
Normy standard najczęściej stosowane:

EN 55022, EN 61000-3-2, EN 61000-3-3, EN 50082-1

EN 60204-1, EN 60335-1

Data/Firma

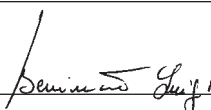

Data/Firma

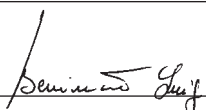

BENINCA®

Automatismi Benincà Srl
Via Capitello, 45
36066 Sandrigo (VI)
ITALIA

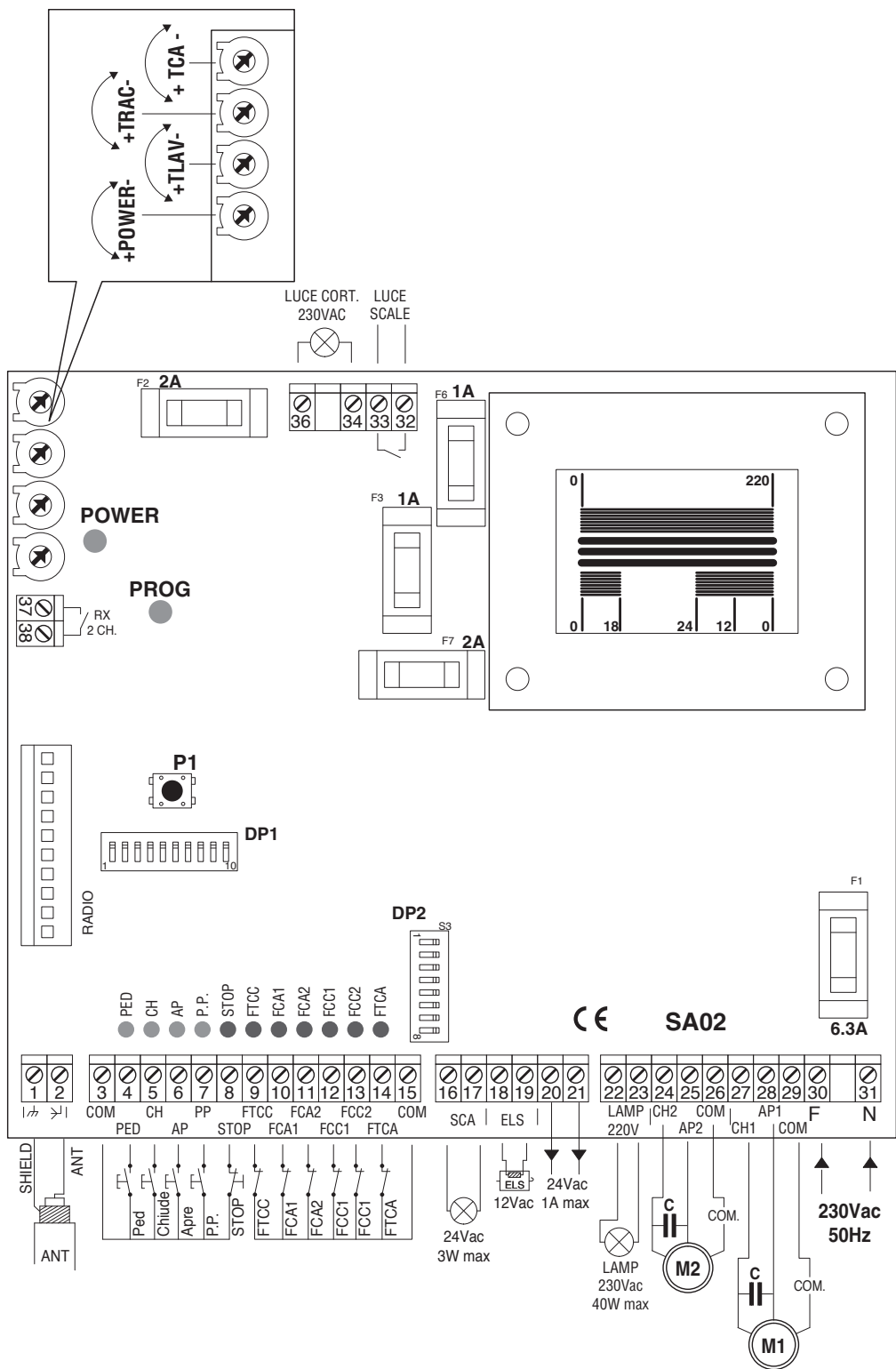

SA.02 Control Unit

The electronic control unit **SA.02** can be used to control 2 motors with a power not exceeding 350+350W.

GENERAL WARNINGS

- a) The wire connections and the operating logic should be in compliance with regulations in force.
- b) The cables featuring different voltage should be physically detached, or adequately insulated by an additional insulation of at least 1 mm.
- c) The cables should be further fastened in proximity to the terminals.
- d) Check all connections before powering the unit.
- e) Check that setting of the Dip-switches are the required ones.

INPUT/OUTPUT FUNCTIONS

Term. NO.	Function	Description
1-2	Aerial	Aerial-receiver card connection (1-screen/2-signal).
3	COM	Common to all control inputs.
4	PED	Input, N.O. pedestrian push-button. Activation is on motor M1 (27-28-29).
5	CH	Input, N.O., Close button.
6	AP	Input, N.O., Open button.
7	P-P	Input, N.O., Step-by-step button.
8	STOP	Input, N.C., STOP button.
9	FTCC	Input, photocell which is activated only during closure.
10	FCA1	Input, N.C., Motor 1 opening limit switch.
11	FCA2	Input, N.C., Motor 2 opening limit switch.
12	FCC1	Input, N.C., Motor 1 closing limit switch.
13	FCC2	Input N.C., Motor 2 closing limit switch.
14	FTCA	Input, photocell which is activated only during opening.
15	COM	Common to all control inputs.
16-17	SCA	Connection, indicator light of open gate, 24 VAC/3W max.
18-19	ELS	Connection, electric lock, 12VAC/0.5A max.
20-21	24 VAC	Output, accessories power supply, 24VAC/1A max.
22-23	Flashing light	Output, flashing warning beacon connection, 230VAC 40W max.
24-25-26	Motor 2	Connection for motor 2 : (24-move/25-move/26-COM). Delay in adjustable closure with Trimmer TRAC.
27-28-29	Motor 1*	Connection to motor 1 : (27-move/28-move/29-COM).
30-31	Power supply	Input, 230VAC 50Hz (keep to 30-Phase/31-Neutral).
32-33	CONT. AUX	Auxiliary voltage-free terminal, "Stairs light" (2A max.).
34-36	LUCE CORT	Output, "Courtesy light" (230VAC/50W max.).
37-38	2CH	Output, second radio channel of two-channel receiver. N.O. voltage-free terminal.

*Should only one motor be in use, connect it to output Motor 1, preset trimmer TRAC to minimum value, cut-off both FCA1 and FCA2 for opening limit switches and FCC1 and FCC2 for closure, by short-circuiting inputs as per wire diagram. Set Dip Bypass (DP2) No. 3-4-5-6 to OFF.

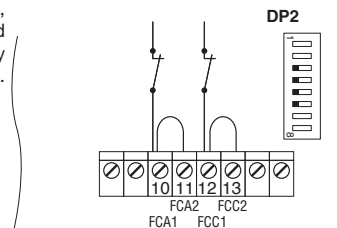

To check connections:

- 1) Cut-off power supply.
- 2) Manually release the wings, move them to approx. half-stroke and lock them again.
- 3) Reset power supply.
- 4) Send a step-by-step control signal by pressing the button or the remote control key.
- 5) The wings should start an opening movement. If this is not the case, invert the movement wires of the motor. (27<->28 for motor M1, and 24<->25 for motor M2) and the relevant limit switch inputs (10<->12 for motor M1, and 11<->13 for motor M2).
- 6) Adjust Time, Operating Logic and Motor Power.

To adjust the motor power

**WARNING! This adjustment affects the safety of the automatic system.
Check that the thrust applied onto the wing complies with regulations in force.**
The motor power can be adjusted by moving the special POWER trimmer.

Functions of Trimmers

- TCA** The automatic closure time can be adjusted with this trimmer. Check Dip-switch DP1 N°5= On. This function can be adjusted between 1 s minimum and 180 s maximum.
- TRAC** It allows to adjust the delay time with which the gate second wing (MOTOR 1) starts closing. Adjustment ranges from 0 s minimum to 40 s maximum.
- TLAV** The maximum time of the opening and closing phases can be adjusted with this trimmer. Time should be preset approx. 4 sec. longer than the actual stroke time of the automatic system. Adjustment ranges from 1 s minimum to 160 s maximum
- POWER** The power of both motors can be adjusted with this trimmer.

Dip-switch DP1 functions

- DIP 1** The operating mode of "Pulsante P.P." (Step-by-step push button) and of the transmitter is selected.
Off: operation: APRE > STOP > CHIUDE > STOP > (Open - Stop - Close - Stop)
On: operation : APRE > CHIUDE > APRE > (Open - Stop - Close - Stop)
- DIP 2** Forewarning flashing light enabled or disabled.
Off: disabled forewarning flashing light.
On: enabled forewarning flashing light. The flashing light is activated 3 s before the motor starts.
- DIP 3** Leave on OFF.
- DIP 4** Selection of Motor 2 delay time during opening (TRAP).
Off: 1 second
On: 2 seconds
- DIP 5** The automatic closure is enabled or disabled.
Off: disabled automatic closure
On: enabled automatic closure
- DIP 6** The multi-flat function is enabled or disabled.
Off: disabled multi-flat function.
On: enabled multi-flat function. The P.P. (Step-by-step) impulse or the impulse of the transmitter have no effect in the opening phase.
- DIP 7** Leave on OFF.
- DIP 8** Activation of "water hammer".
Off: Disabled
On: Enabled. Before starting the gate opening movement, the gate is pushed further closed for about 2 s, in order to facilitate the electric lock release.
- DIP 9** Not in use.
- DIP 10** To select the activation time of outputs "Courtesy light" and "Stair light".
Off: 120 seconds
On: 2 seconds

NOTE: All adjustment of Trimmers and Dip-switches should be carried out with motor stopped.

TRAP/TRAC deactivation

The delay function can be deactivated in the opening (TRAP) and closing (TRAC) phases by proceeding as follows:

Deactivation :

- 1 Move Dip-switch 1 of the selector switch DP1 to OFF, all others to ON.
- 2 Press button P1, wait that LED PROG switches off.
- 3 Move the Dip-switches to the original position.

Activation :

- 1 Move Dip-switches 2-3-4 of the selector switch DP1 to ON, all others to OFF.
- 2 Press button P1, wait that LED PROG switches off.
- 3 Move the Dip-switches to the original position.
- 4 Time preset with trimmer TRAC and dip-switch 4 TRAP is thus reset.

To check the good conditions of the power circuit

The control unit provides testing of the power circuit good conditions (TRIAC). The unit comes factory-adjusted with this function disabled.

This test function can be enabled or disabled as follows:

To enable the test function to check the power circuit good conditions:

- 1 Move Dip-switches 3-5 of the selector switch DP1 to ON, all others to OFF.
- 2 Press button PGM, wait that LED PROG switches off.
- 4 Move the Dip-switches to the original position.
- 5 With function activated, should a failure in the power circuit occur or in case of faulty thermal switch in the motor, all LED's of the "Power" band will start flashing. The control unit will execute no control.

To disable the test function to check the power circuit good conditions:

- 1 Move Dip-switch 3 of the selector switch DP1 to ON, all others to OFF.
- 2 Press button PGM, wait that LED PROG switches off.
- 3 Move the Dip-switches to the original position.
- 4 With the deactivated function, even in the case of faulty power circuit, the control unit will execute the controls.

Functions of Dip-switch DP2 "BYPASS"

The Dip-switches "Bypass" allow to short-circuit Normally Closed inputs which are not in use.

DIP 1	STOP Input Off: Enabled Input On: Disabled Input
DIP 2	FTCC Input Off: Enabled Input On: Disabled Input
DIP 3	FCA1 Input Off: Enabled Input On: Disabled Input
DIP 4	FCA2 Input Off: Enabled Input On: Disabled Input
DIP 5	FCC1 Input Off: Enabled Input On: Disabled Input
DIP 6	FCC2 Input Off: Enabled Input On: Disabled Input
DIP 7	FTCA Input Off: Enabled Input On: Disabled Input
DIP 8	Not in use

LED diagnostics

The control unit is complete with a series of self-diagnostic LED's which allow checking of all functions:

LED PED	It switches on when the PEDONALE (Pedestrian) Input is activated
LED CH	It switches on when the CHIUDE (Close) Input is activated
LED AP	It switches on when the APRE (Open) Input is activated
LED P.P.	It switches on when the Passo-Passo (Step-by-Step) Input is activated
LED STOP	It switches off when the STOP Input is activated
LED FTCC	It switches off when photocells are not aligned or obstacles are present during closure
LED FCA1	It switches off when Motor 1 Opening Photocell Input is activated
LED FCA2	It switches off when Motor 2 Opening Photocell Input is activated
LED FCC1	It switches off when Motor 1 Closing Photocell Input is activated
LED FCC2	It switches off when Motor 2 Closing Photocell Input is activated
LED FTCA	It switches off when photocells are not aligned or obstacles are present during opening
LED POWER	Shows mains power supply.
LED PROG	It flashes to show the micro-processor correct operation.

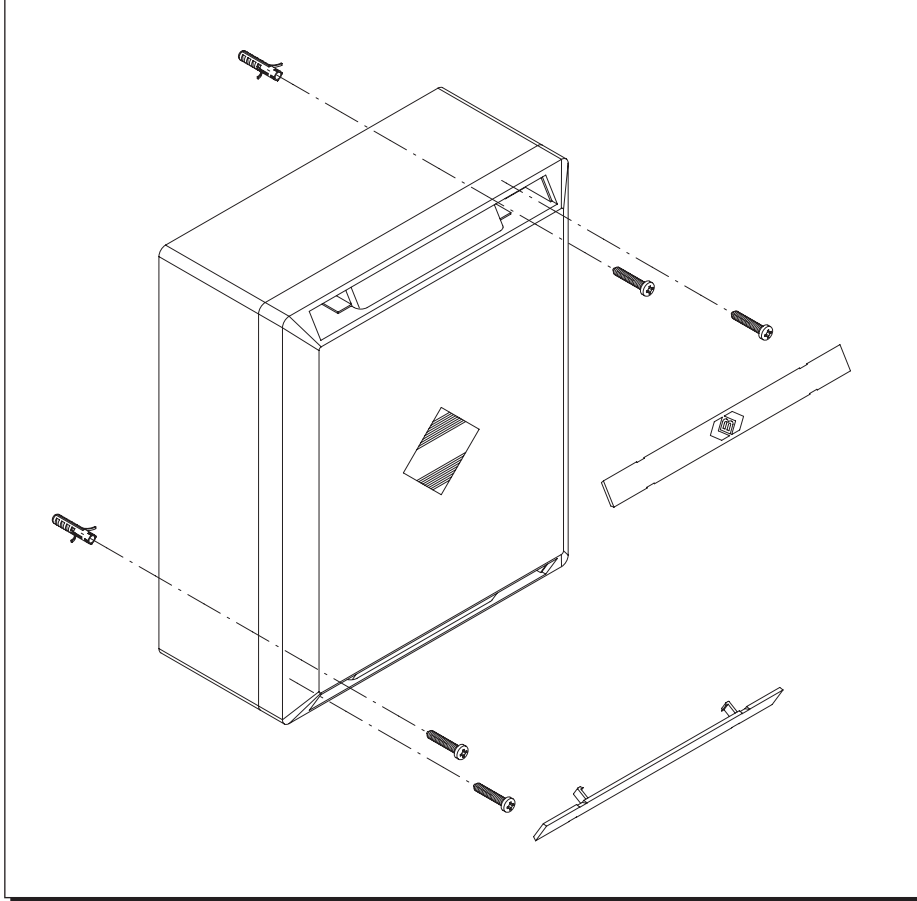

BENINCA®

AUTOMATISMI BENINCA® Srl - Via Capitello, 45 - 36066 Sandrigo (VI) - Tel. 0444 751030 r.a. - Fax 0444 759728
