

# Electronic Locking Magnet Range



**Shear Lock (2600lb)**

### Technical specifications

- Door open delay timer (0.5 - 25 seconds)
- Door position detection outputs
- 12v or 24v DC (auto adjusting)
- Operating Current 900mA @ 12 or 24V DC
- Holding Current 220mA @ 12vDC / 190mA @ 24vDC
- Maximum shear force of 1200Kg or 2600lbs
- Operating temperature 0-90C
- Monitoring Relay: NO and NC contacts (Rated 24V/1A)

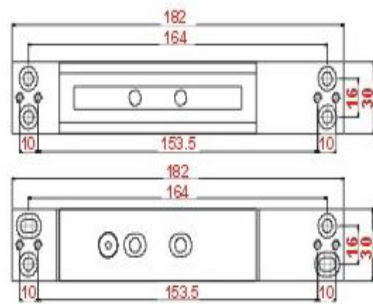

### FEATURES

- Automatic repeated locking (maximum 60 times)
- Suitable for wooden and aluminium door types.
- Made from fireproof materials
- Magnetic Distance (Max)  
3mm @ 12V DC  
5mm @ 24V DC

MSL2600	182x25x30 (mm)	Shear lock (2600lb)	1.2Kg (Boxed) / 582g (Unboxed)
Armature	182x24x30 (mm)	Armature Plate	266g (Unboxed)

Other items in the RGL range.

