

Electronic Control Unit LRX 2215 GB

Electronic control unit for the automation of rolling shutters and sun blinds, with optional Wind sensor connection and keypad/radio control operation, for individual and centralised control.

- Mod. **LG 2215** : Without radio receiver
- Mod. **LRS 2215** : 433,92 MHz
- Mod. **LRS 2215 SET**: "Narrow Band" 433.92 MHz
- Mod. **LRH 2215** : "Narrow Band" 868.3 MHz

TECHNICAL DATA

- Power supply: 230 V~ 50/60 Hz 600 W max.
- Motor output: 230 V~ 500 W Max.
- Operating temperature: -10÷55°C
- Radio receiver: see model
- Compatible radio controls: 12-18 Bit or Rolling Code
- N° of codes which may be stored: Max. 6
- N° of Wireless Wind Sensors which may be stored: Max. 3
- Packaging dimensions: 110 x 121 x 47 mm.
- Container: ABS UL94V-0 (IP54)

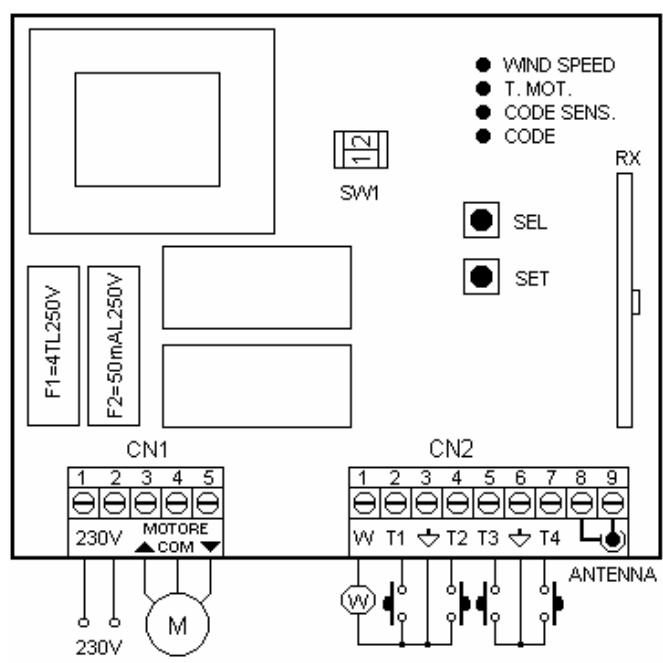

CONNECTION OF CN1 TERMINAL BOARD

- 1: 230 V line input (Phase).
- 2: 230 V line input (Neutral).
- 3: Upward movement motor output.
- 4: Shared motor output.
- 5: Downward movement motor output.

CONNECTION OF CN2 TERMINAL BOARD

- 1: Wind sensor input "W".
- 2: T1 local upward movement button input (NA).
- 3: Shared GND Signal input.
- 4: T2 local downward movement button input (NA).
- 5: T3 general upward movement button input (NA).
- 6: Shared GND Signal input.
- 7: T4 general downward movement button input (NA).
- 8: Earth antenna input.
- 9: Antenna hot pole input.

INITIAL OPERATING CONDITION

The equipment can operate using the T1 (Up) and T2 (Down) local command buttons, the T3 (Up) and T4 (Down) general command buttons, and in conjunction with one or more radio controls. There is no radio control code stored in the default factory setting.

OPERATIONAL DATA:

T1 – T2 Local command buttons operation:

The following type of operation is obtained by connecting the local command buttons (normally open) for movement activation to the low voltage inputs T1 – T2:

T1 controls upward movement until the motor running time has elapsed and T2 controls downward movement. If a command is sent in the same direction before the motor running time has elapsed, the control unit will stop movement; if a command is sent in the opposite direction before the motor running time has elapsed, the control unit will invert the direction of the motor.

T3 – T4 General command buttons operation:

The following type of operation is obtained by connecting the general command buttons (normally open) for movement activation to the low voltage inputs T3 – T4:

T3 controls upward movement until the motor running time has elapsed and T4 controls downward movement. If a command is sent in the same direction before the motor running time has elapsed, the control unit will ignore the command; if a command is sent in the opposite direction before the motor running time has elapsed, the control unit will invert the direction of the motor.

OPERATION USING DIFFERENT MODELS OF RADIO CONTROL

Different models of radio control may be programmed: by storing one code (1 button) a cyclic step by step operation (Up - Stop - Down) is achieved, and by storing two different codes (2 buttons) separate commands are created, one for upward movement and one for downward movement. Storing a BeFree series radio control (3 buttons) produces three separate commands: the first button is used for upward movement, the second for Stop and the third for downward movement.

Operation using a 1-button radio control:

The following type of operation is obtained using a radio control with a single button: the first press controls the upward movement of the shutter until the motor timer stops. The second press controls the downward movement of the shutter. If the button is pressed before the motor stops running, the control unit will stop the shutter moving and the button will need to be pressed again to reactivate the motor in the opposite direction.

Operation using a 2-button radio control:

The following type of operation is obtained using a radio control with 2 buttons: the first button ("Up", corresponding to upward movement) controls upward movement until the motor stops running and the second button ("Down", corresponding to downward movement) controls the downward movement of the shutter. If the upward movement is interrupted with another "Up" command, the motor will continue to run in its upward movement direction. If, however, the movement is interrupted with a "Down" command, the control unit will stop the motor.

The procedure remains the same for the downward movement phase.

Operation using a 3-button radio control (BeFree x1):

The following type of operation is obtained using the BeFree x1 radio control: the (Up) button controls upward movement until the end of the motor running time, the (Stop) button causes all movement to stop and the (Down) button controls downward movement. If a Stop command is sent during upward or downward movement, the control unit causes this movement to stop. If a command that is in the opposite direction to the cur-

rent movement is sent during upward or downward movement, the control unit causes the shutter to change direction.

Operation using a 3-button radio control (BeFree x3 - X6):

When using the BeFree x3 - x6 radio control, you will obtain the same type of operation as previously described for the BeFree x1 version; furthermore, the buttons (-) and (+) at the sides of the radio control may be used to select the (Up - Stop - Down) commands for 6 different types of operation. Press and hold the two buttons on the sides of the radio control (-) and (+) for a few moments to enable and disable sun sensor operation (this selection is confirmed by the brief up/down movement made by the motor).

INVERSION OF THE ROTATION MOTOR

If you notice that when pressing the (Up) button on the radio-control the control unit causes the shutter to move downwards instead of upwards, simply repeat the programming procedure pressing the (Down) button instead of the (Up) button, or invert the upward movement wire and the downward movement wire of the motor.

GROUP OR GENERAL CENTRALISATION

Centralisation via cable using buttons

The centralisation of two or more control units enables upward or downward movement to take place simultaneously in the connected pieces of equipment. Centralisation can be performed by connecting the three wires for inputs T3 (Up), T4 (Down) and the shared reference point "GND Signal" in parallel.

Centralisation via radio using a radio control

The centralisation of two or more control units enables upward or downward movement to take place simultaneously in the pieces of equipment.

Centralisation is performed by entering two identical codes (buttons) from one radio control onto all the control units, or a group of them which are situated at a maximum distance of 20 metres from the point of command, in order to obtain general or partial motion of more than one automation. To achieve satisfactory radio centralisation, the installation site should be chosen carefully. The field of action is not only linked to the technical features of the device, but also varies according to the radio-electrical conditions of the site itself.

ANEMOMETER OPERATION

The electronic control unit will cause the sun shade to move upwards every time the wind exceeds the selected threshold.

OPERATING LOGIC SW1 SW1 SW1 SW1

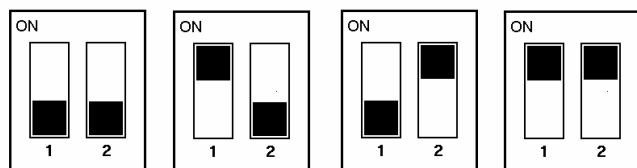

Step-by-step P/P + Aut Sensors User Present Venetian Blind

1) Step-by-step (Dip 1 and 2 OFF)

The electronic control unit has a cyclic "Step-by-Step" logic, whose operation depends on the type of control associated with it, keypad or radio control (see operation with 1-2-3 button radio control).

2) Step-by-step + Automatic sensors (Dip 1 ON and Dip 2 OFF)

The electronic control unit allows "Step-by-Step" operation as described above, with the addition of automatic Wind sensor control. After the activation of one of the two sensors, once the disturbance is over, the electronic control unit controls the downward movement of the sun shade after 10 minutes.

3) User present (Dip 1 OFF and Dip 2 ON)

The "User present" operating mode can be obtained using the radio control and the keypad, i.e. control must be constantly enabled so that the blind or shutter can be moved as necessary. The movement stops when the control is released.

4) Venetian blind operation (Dip 1 and 2 ON)

Venetian blind operation can be obtained using the radio control and the keypad; this involves 2 seconds of User Present operation at the very start. It is possible, in this manner, to rotate the slats of the Venetian blind in one direction or the other in order to modulate the amount of light filtering through as desired. If the transmitted commands last longer than 2 seconds, the blind will move upwards or downwards (depending on the button pressed) until the motor running time has elapsed.

PROGRAMMING BUTTONS AND INDICATOR LEDES

SEL button: selects the type of function to store in the memory; selection is indicated by the LED flashing. The desired function can be selected by pressing the button repeatedly. The selected function remains active for 15 seconds (flashing LED), after which the control unit returns to its original status.

SET button: programmes the function that has been selected using the SEL. button.

Indicator LEDs

LED lit: option stored.

LED off: option not stored.

LED flashing: option selected.

----- MAIN MENU -----		
Reference LED	LED Off	LED On
1) CODE	No code	TX Pgm code
2) SENS. CODE	No code	Sensor code pgm.
3) T. MOT.	Motor running time 2 minutes	Motor running time pgm.
4) WIND SPEED	Wind safety 25 km/h	Wind safety pgm.

1) CODE (Radio control programming)

Programming using a 1- or 2-button radio control:

To programme the transmission codes in the radio control, proceed as follows: press the SEL button; the CODE LED begins to flash. Send the first preselected code using the relevant radio control at the same time; the CODE LED begins to flash rapidly. Send the second code to be stored: the CODE LED will remain lit and programming will be complete. If the second code is not sent within 10 seconds the control unit exits the programming stage, selecting operation using a single button on the radio control.

Programming using a 3-button radio control in the "BeFree" series:

The control unit allows you to store the whole "BeFree" radio-control by programming only the Up button.

To programme the "BeFree" radio control codes, follow this procedure: press the SEL button; the CODE LED begins to flash. Press the Up button on the desired radio control at the same time; the CODE LED will remain lit and programming will be complete.

Deleting the codes:

To delete all transmission codes stored in the memory, proceed as follows: press the SEL button; the CODE LED will start to flash. Then press the SET button; the CODE LED will switch off and the procedure is complete.

Radio control already stored warning:

If the user attempts to perform the programming procedure for a radio control which is already stored in the memory, the CODE LED will begin to flash rapidly for a few moments, to indicate that this procedure cannot be performed; the unit then returns to the programming stage once again.

Maximum number of radio controls which can be stored:

If the maximum number of radio controls has been reached and a programming process started, the control unit will indicate that it has failed by flashing all the LEDs except the CODE LED, which will remain lit in a constant manner. After 10 seconds the control unit exits programming mode.

2) SENS. CODE (Wireless Sensor programming)

Wireless Wind sensor programming:

To programme the Wireless Wind Sensor transmission code, proceed as follows: Use the SEL button to navigate to a position where the SENS. CODE LED flashes; at the same time, send the Wireless Wind sensor code using the special button inside the sensor. The SENS. CODE LED will remain lit in a fixed manner and programming will be complete. If the Wireless Wind sensor code is not sent within 2 minutes, the control unit exits programming mode.

Deleting the codes:

To delete the Wireless Wind sensor codes stored in the memory, proceed as follows: press the SEL button; the SENS. CODE LED will start to flash. Then press the SET button; the SENS. CODE LED will switch off and the procedure is complete.

Wireless Wind sensor already stored warning:

If the user attempts to perform the programming procedure for a Wireless Wind sensor which is already stored in the memory, the SENS. CODE LED will begin to flash rapidly for a few moments, to indicate that this procedure cannot be performed; the unit then returns to the programming stage once again.

Maximum number of Wireless Wind sensors which can be stored:

If the maximum number of Wireless Wind sensors has been reached and a programming process started, the control unit will indicate that it has failed by flashing all the LEDs except the SENS. CODE LED, which will remain lit in a constant manner. After 10 seconds the control unit exits programming mode.

Warning indicator:

If there is no communication between the Wireless Wind sensor and the control unit, after 20 minutes the safety upward movement will be activated automatically. If this lack of communication persists, further commands will still, nevertheless, result in the control unit being set to safety mode.

3) T. MOT. (Max. Motor Timer programming time 4 minutes)

The control unit comes with a motor power supply time of two minutes (T. MOT. LED OFF).

The motor running time must be programmed when the shutter is down, in the following manner:

Press the SEL button until the T. MOT LED flashes, then press and hold the SET button; the shutter will begin to move upwards. Once the desired position has been reached, release the SET button – at this very moment, the motor running time will be stored and the T. MOT LED will remain lit.

If you are using an automation which has a stop limit, we recommend that you set a time which exceeds the stop limit of the shutter by a few seconds.

If you want unlimited motor running time, perform the same programming procedure, holding down the SET button for less than two seconds; the T. MOT LED will remain lit and the unlimited time function will be set. The procedure may be repeated if a mistake is made during programming.

4) WIND SPEED (Wind Safety threshold programming)

Displaying the programmed Wind threshold:

The Wind Safety threshold may be displayed in the following way: use the SEL button to navigate to the WIND SPEED LED position; the LED will double-flash the same number of times as the stored Wind Safety threshold (each WIND SPEED LED double-flash corresponds to an increase of 5 km/h), (for example: 5 WIND SPEED LED flashes = 25 km/h).

Wind Safety threshold selection from 5 to 40 km/h

The sensor is supplied with a default Wind Safety threshold setting of 25 km/h (WIND SPEED LED OFF).

The Wind Safety threshold may be programmed in the following way: use the SEL button to navigate to the WIND SPEED LED, then press the SET button to start the programming procedure: the WIND SPEED LED will double-flash at the same time (each WIND SPEED LED double-flash corresponds to an increase of 5 km/h). Press the SET button when the desired threshold has been reached; at that moment the selected value will be stored in the memory and the WIND SPEED LED will remain lit (for example: 5 WIND LED double-flashes = 25 km/h).

The procedure may be repeated if a mistake is made during programming.

EXTENDED MENU 1

The control unit is supplied by the manufacturer with the option of selecting only the functions listed in the main menu.

To enable the functions of extended menu 1, proceed as follows: press and hold the SET button for 5 seconds; the T. MOT. and WIND SPEED LEDs will start flashing alternately. The user then has 30 seconds in which to select the extended menu functions using the SEL and SET buttons. After 30 seconds the control unit returns to the main menu.

----- EXTENDED MENU 1 -----		
Reference LED	LED Off	LED On
A) CODE	remote PGM = OFF	remote PGM = ON
B) SENS. CODE	Safety upward mov. =OFF	Safety upward mov. =ON
C) T. MOT.	Flashing beacon ON/OFF	
D) WIND SPEED	Flashing beacon ON/OFF	

A) CODE

(Remote programming of radio control):

The control unit allows the transmission code to be programmed remotely, without using the SEL button on the unit itself.

To programme a transmission code remotely, proceed as follows: send the radio control code continuously for more than 10 seconds; the control unit will enter the programming mode as described above for the CODE LED in the main menu.

The control unit is supplied by the manufacturer with remote programming of a transmission code not enabled; to enable the function proceed as follows: check that the extended menu is enabled (T. MOT. and WIND SPEED LEDs start flashing alternately), use the SEL button to navigate to the CODE LED when flashing and press the SET button: the CODE LED remains lit in a constant manner and programming is complete. Repeat the procedure to restore the previous configuration.

B) SENS. CODE (Safety upward movement):

The control unit is supplied by the manufacturer with the Safety upward movement function disabled; if you wish to enable the function, so that after 12 hours of Wind sensor inactivity the control unit automatically sends a command for Safety upward movement, proceed as follows: check that the extended menu is enabled (T. MOT. and WIND SPEED LEDs start flashing alternately), use the SEL button to navigate to the SENS. CODE LED when flashing and press the SET button: the SENS. CODE LED remains lit in a constant manner and programming is complete. Repeat the procedure to restore the previous configuration.

EXTENDED MENU 2

The control unit is supplied by the manufacturer with the only option of selecting the functions listed in the main menu directly.

To enable the functions in extended menu 2, proceed as follows: access extended menu 1 (as described in the corresponding paragraph), then press the SET button again and hold for 5 seconds; the T. MOT. and WIND SPEED LEDs will flash alternately and the user has 30 seconds within which to select the functions of extended menu 2 using the SEL and SET buttons. When this time has elapsed the control unit returns to the main menu.

----- EXTENDED MENU 2 -----		
Reference LED	LED Off	LED On
A) CODE	Auto movements = OFF	Auto movements = ON
B) SENS. CODE	Anemometer Test = OFF	Anemometer Test = ON
C) T. MOT.	Flashing beacon ON/OFF	
D) WIND SPEED	Flashing beacon ON/OFF	

A) CODE (Automatic Movement Lock):

The control unit enables the prevention of automatic movements (Up / Down sun blind movements on the Wind sensor command or Automatic sensors function), so that if a Stop command is sent from a radio control during movement, the control unit momentarily locks the automatic movements until a new Up or Down command is sent.. The control unit is supplied by the manufacturer with the Automatic Movement Lock disabled; to enable the function proceed as follows: check that the extended menu is enabled (T. MOT. and WIND SPEED LEDs start flashing simultaneously), use the SEL button to navigate to the CODE LED when flashing and press the SET button: the CODE LED remains lit in a constant manner and programming is complete. Repeat the procedure to restore the previous configuration.

B) SENS. CODE (Wired Anemometer Test):

The control unit can be used to check the operation of the connected Wind sensor, and to make sure the rotation direction is correct. When installing the device, we recommend the blind is placed in an intermediate position so that you can see all confirmation movements during the test procedures. After making sure the Wind sensor is operating correctly, you must remember to disable the Test.

Anemometer Test: manually rotate the Anemometer blades; at the same time, the control unit will cause an upward movement lasting 5 seconds.

Programming: The control unit is supplied by the manufacturer with the Wired Wind sensor test disabled. To enable the Test, proceed as follows: check that extended menu 2 is enabled (T. MOT. and WIND SPEED LEDs start flashing simultaneously), use the SEL button to navigate to the SENS. CODE LED when flashing and press the SET button: the SENS. CODE LED remains lit in a constant manner and programming is complete. Repeat the procedure to restore the previous configuration.

Important: for information on the Wireless Wind sensor test, please refer to the Wireless Wind sensor manual.

RESET

To reset the default configuration of the control unit, press the SEL and SET buttons simultaneously; all indicator LEDs will switch on and then off again immediately.

FOR THE INSTALLER - IMPORTANT

- The control unit was designed to enable the installer to automate shutter movement while adhering to the provisions set out by current legislation. Compliance with these obligations and the implementation of the minimum safety requirements is the responsibility of the installer.

We recommend installation is performed in full compliance with EN 60335-2-97 ("Household electrical appliances and similar - Safety", part 2 "Particular requirements for drives for rolling shutters, awnings, blinds and similar equipment).

In this regard, realise the plant combined with this components control unit (motor, mechanical parts, etc.) resulting conform in satisfying the necessary safety requisites.

- The control unit must be permanently connected to the power supply network and is not equipped with any type of 230 V a/c electric line sectioning device. The installer is responsible for installing a sectioning device in the system. An omnipolar switch with overheating category III must be installed. It must be positioned in such a way that it is protected against accidental closures.

- For connections (power supply and motor output) we recommend the use of flexible wires with an insulating sheath in harmonised polychloroprene (H05RN-F). The wires should have a minimum cross-section of 0.75 mm².

- Fasten the connection cables using the cable clamp supplied with the product kit.

- In choosing the motor to combine with the control unit, keep to the maximum power indications contained in this manual.

- For the radio receiver to operate correctly when two or more control units are used, we recommend that you install the devices at least 3 metres away from each other.

- If two or more control units are installed, we recommend only one Wireless Sensor is used in order to avoid radio interference.

The below products:

LG2215 – LRS2215 – LRS2215 SET – LRH2215

conform to the specifications in the Directives R&TTE 99/5/EC, EMC 2004/108/EC, LVD 2006/95/EC.



FOR THE USER - IMPORTANT

- The device should not be used by children or by individuals with reduced physical or psychological abilities unless supervision is provided or instruction given on how to operate it.

- Do not let children play with the device; keep radio controls out of their reach.

- CAUTION: Keep this instruction manual in a safe place and observe the important safety instructions contained within it. Non-observance of these instructions may lead to property damage and serious accidents.

- Examine the system frequently to check for any signs of damage. Do not use the device if it needs to be repaired.

- We recommend carrying out the opening and closing operations of the blind or rolling window shutter in visible conditions, ensuring no persons are in a dangerous condition during movement.

Warning

All procedures which require the casing to be opened (such as wire connection, programming, etc.) must be carried out during installation, by skilled staff only. For any other procedure which requires the casing to be opened again (re-programming, repairs or site modifications), please contact the technical assistance service.