

# ELECTRONIC PANEL LG 2020



Remote control reverser for the low-tension command of motors for rolling shutters and roller blinds.

## TECHNICAL DATA

- Power supply: 230V~ 50-60Hz 6W
- Low-tension command 24V: Open Common Close
- Motor output: 230V~ 500W Max
- Working temperature: -20÷85°C
- Dimension of panel: 110x121x47 mm
- Container: ABS V-0 (IP54)

## TERMINAL BOARD CONNECTIONS

- 1: 230V~ input (L1)
- 2: 230V~ input (N)
- 3: Opening motor output
- 4: Common motor output
- 5: Closing motor output
- 6: Opening low-tension command input
- 7: Common low tension command input
- 8: Closing low-tension command input
- 9: 24V~ 7W Max duty feed output
- 10: 24V~ 7W Max duty feed output

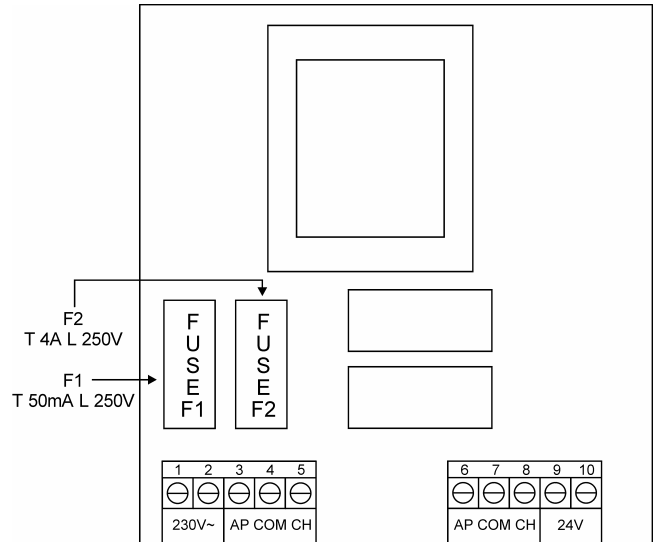

**IMPORTANT NOTICE FOR THE INSTALLER**

- The centre does not have any type of sectioning mechanism, it is therefore the responsibility of the installer to see to the installation of a sectioning device within the plant.
- The fixing of the electricity supply cables and their connection, must be guaranteed by means of the assembly of the cable presses which are provided in the packaging.

The product  
**Electronic Exchange LG 2020**  
 complies with the requirements of the Directives EMC 2004/108/EC, LVD 2006/95/EC.

### CONNECTION WIRING DIAGRAM 1: MOTOR + LOW-TENSION PUSH-BUTTON PANEL

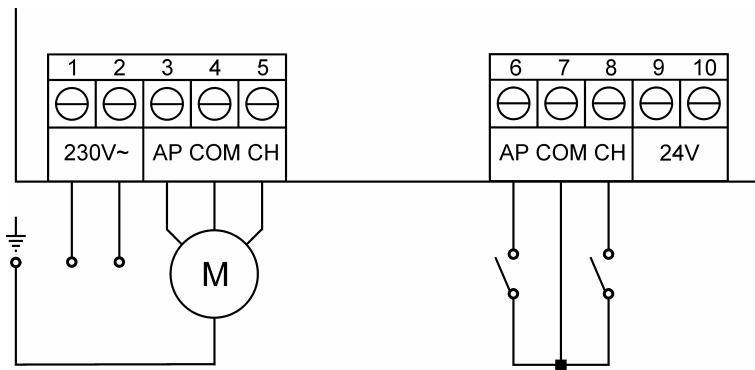

### CONNECTION WIRING DIAGRAM 2: MOTOR + LOW TENSION PUSH-BUTTON PANEL + FLASH-LIGHT + PHOTOELECTRIC CELL

