

TCO7RX / TCO7TX

**Transceiver system for mechanical safety and
8,2K resistive edges**

TRANSMITTER : TCO7TX

RECEIVER : TCO7RX



Transceiver system

1. DESCRIPTION

The system is intended as safety device for gates and includes a receiver (connected to the control unit) and a maximum of 8 transmitters (4 for each of the two relays of the receiver) connected to the sensitive edges. It can work both with the clean NC contact mechanical edges, and with the 8,2K edges. The two contacts of the receiver (normally closed with the powered device) are independent and can be connected to the relative input of the control unit, put in series to the stop of the control unit, or in series to the photo devices contacts. Two contacts are also present on the receiver to be able to carry out the self – test system.

The transmission of the signals between transmitter and receiver happens on 868 MHz band in bidirectional way.

The installation and the maintenance of the system must be carried out by qualified personnel. The manufacturer can not be considered responsible for any damages caused by an improper, incorrect or irrational use of the product.

Warning: this device can block the automation if the batteries of the mobile part is flat.

2. CONFIGURATION AND ELECTRICAL CONNECTIONS

2.1 Receiver TCO7RX

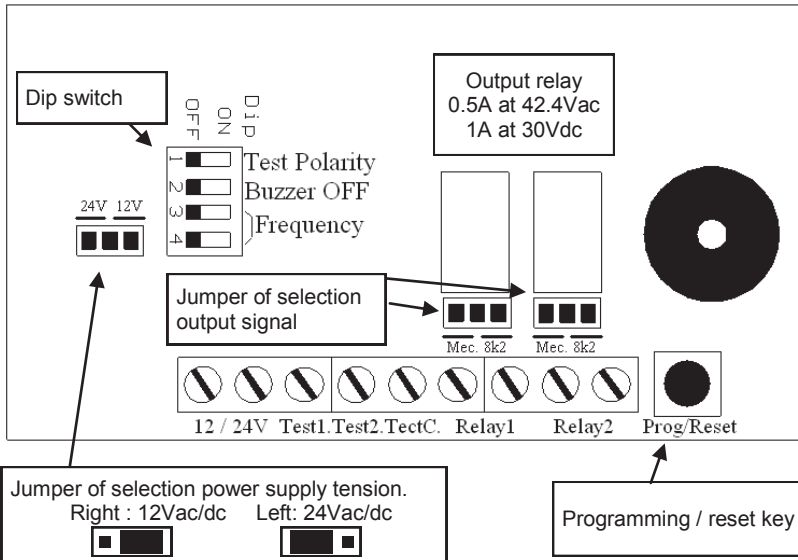

WARNING: if the power supply of the TCO7RX is carried out in alternating current (Vac), the power supply must be got through an insulation transformer (of security, SELV tensions) which has a limited power or almost a protection against the short circuit.

NOTE: The signal given on output (clean contact or 8,2K) to the relay 1 and 2 depends on the position of the selection output signal jumper.

NOTE: The level of acoustic pressure generated by the device is less then 70 dBA.

2.2 Transmitter TCO7TX + mechanical edge

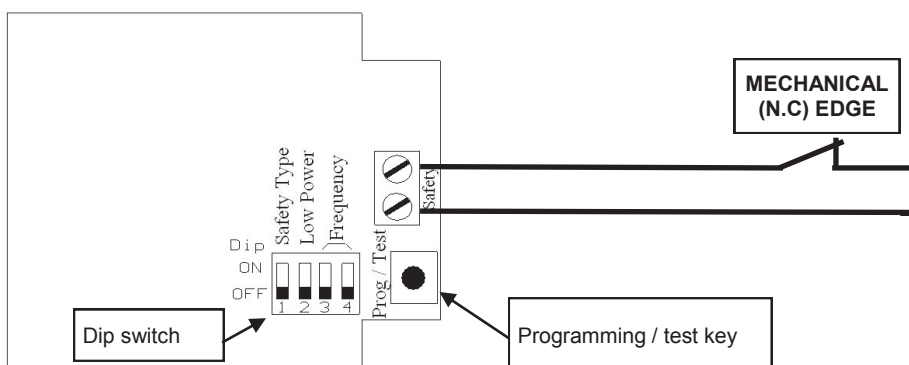

WARNING:

DIP1 OFF: mechanical safety edge
If you want to connect a NON-resistive element (normally closed contact), you must set dipswitch 1 on "OFF".

WARNING: this application does not comply with the automatic doors security norm for use EN 12453 because the connection of the non-resistive component connected to the transmitter is not checked.

2.3 Transmitter TCO7TX + 8,2K resistive edge

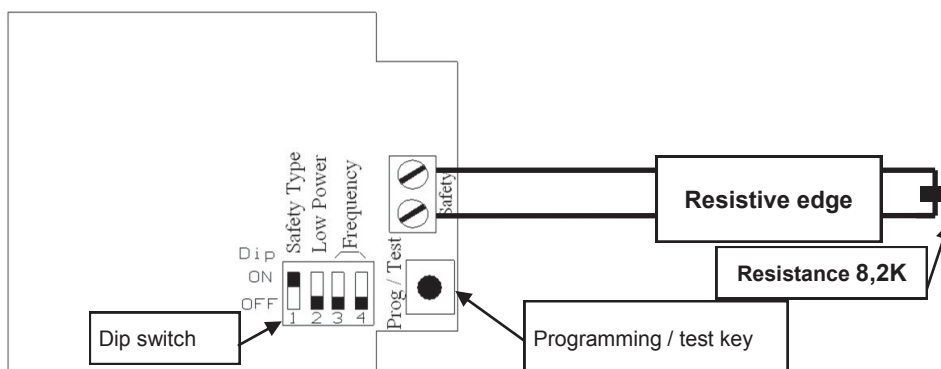

WARNING:

DIP1 ON: resistive safety edge 8,2K
If you want to connect a resistive element (8k2 resistor), you must set dipswitch 1 on "ON".

3. SETTINGS

TRANSMITTER TCO7TX

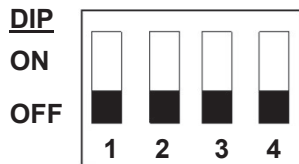

N° DIP	Function
1	Mechanical or resistive safety edge.
2	Energy saving
3	Selection frequency of functioning
4	

RECEIVER TCO7RX

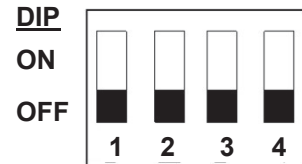

N° DIP	Function
1	Test device
2	Buzzer ON / OFF
3	Selection frequency of functioning
4	

It is possible to associate up to a maximum of 4 transmitters (4 different edges) to each relay. For this reason, to each receiver can be associated a maximum of 8 transmitters.

Warning: for a correct functioning of the system, every transmitter part must have the frequency dip put on the same way as the correspondent receiver part.

In order to avoid any interferences on installations which need a higher number than 4 security channels it is advisable to distinguish the frequencies utilized among the various receivers and their transmitters associated transmitters.

4. CONNECTIONS

4.1 Transmitter connection

- 1 Connect the safety edge to the terminals of the transmitter. Direct and place the device as shown on the figure.
- 2 Set the dip switch relative to the utilized frequency (dip 3 and dip 4) which will have to correspond to the one of the receiver.
- 3 Give power to the system connecting the two batteries AA – 1,5 V to the battery holder. **Pay attention to the polarity.**
- 4 Fix the device as much higher than possible in such way as there are no obstacles on the direction of the receiver and in such a way as the maximum distance between the two devices is less than 30 meters.

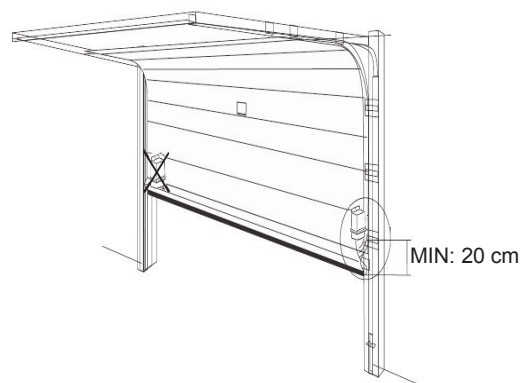
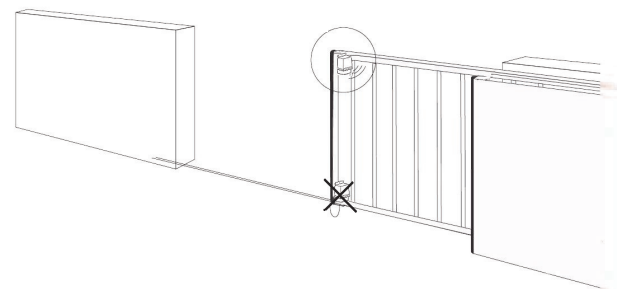

4.2 Receiver connection

- 1 Put the receiver in such a way to minimize the distance from the transmitters associated and close the to the automation's control unit or inside the box of the motor. If fixed to a wall, utilize suitable screws and plugs so that it can resist to a force of 50N downwards.
- 2 Set the dip switch relative to the utilized frequency (dip 3 and dip 4) which will have to correspond to the one of the transmitters.
- 3 Set the 2 little bridges Mec/8K2 (Jumper of selection output signal) in such a way as the state of functioning or of alarm is correctly signaled, according to whether the control unit has an input of mechanical type (with contact) or 8,2KΩ.
- 4 Set the little bridge of power supply (24V o 12V)
- 5 Connect the test inputs to the control unit, in case they are utilized (*).

WARNING : The manufacturer can not be considered responsible for any damages caused by an improper, incorrect or irrational use of the product.

WARNING: keep free the areas of access to the devices and clean periodically them from eventual dirtiness which can settle on them during the normal functioning.

(*) The inputs are handled in the same way as the photocells test: the control unit, to carry out the photocells test, switches off the power supply of the receiver and check that the relays of the correspondent receiver opens itself. In this device, the input TEST1 and TEST2 are for testing the security devices (see chapter 12).

5. LEARNING

5.1 Learning of the transmitters on the first relay of the receiver

- 1 **Check that the DIP 3 and 4 of the transmitter and of the receiver are set in the same way.**
- 2 **Press and keep pressed** the key present on the receiver. → The receiver emits **1** bip
- 3 **Release** the key on the receiver.
- 4 **Press and keep pressed** the key present on the transmitter. → The receiver emits **2** bips.
- 5 Release the key of the transmitter → The learning ended correctly.

For the successive learning, repeat the operation from point 1.

5.2 Learning of the transmitter on the second relay of the receiver

- 1 **Check that the DIP 3 and 4 of the transmitter and of the receiver are set in the same way.**
- 2 **Press and keep pressed** the key present on the receiver. → The receiver emits **1** bip
- 3 **DO NOT** release the key on the receiver. → The receiver emits **2** bips.
- 4 **Release** the key on the receiver.
- 5 **Press and keep pressed** the key present on the transmitter. → The receiver emits **2** bips.
- 6 Release the key of the transmitter → The learning ended correctly.

NOTE: in case in which instead 4 BIP are reproduced, it means that the maximum number of transmitters for the selected channel has been reached and that no new devices on the same relay can be memorized.

In case in which a device previously memorized is then associated to the other relay, it will be automatically removed from the previous relay. For example, if a device memorized on the relay 1 is memorized on the relay 2 it will be automatically removed from the relay 1.

5.3 Summary of the acoustic signalling during the learning phase

Acoustic signalling during the learning phase	
Number of BIP	Meaning
2	Transmitter correctly memorized
4	Mistake : the maximum number of transmitter for selected channel has been reached
1	Maximum time up for the memorization of the transmitter (10 second)

6. SELECTION OF THE TYPE OF SIGNAL ON OUTPUT RELAY

Beside the two receiver relays a jumper for the selection of the type signal to give on output is present. This signal can be:

1. A clean contact : open contact in case of alarm and close if the alarm is not present
2. A contact type 8,2K : resistance of the contact = 0 or ∞ (Open loop) Ohm in case of alarm and 8,2KΩ if the alarm is not present. The control unit connected to the device must be able to handle this type of signal.

The selection of the type of signal is carried out in the following way:



MEC.

Jumper Pos. 1



8K2

Jumper Pos. 2

Position 1 : clean contact functioning (Mec)
Position 2 : 8K2 functioning (8,2K)

7. SELECTION OF THE WORKING FREQUENCY

For each receiver and relative transmitters it is possible to select a frequency of work. This allows to be able to utilize up to a maximum of 4 receivers on the same range of action without interferences.

For a correct functioning of the system **it is indispensable** that the frequency set on the receiver corresponds to the frequency set on the associated transmitters.

The selection of the frequency happens with DIP 3 and 4 as reported on the following table:

	DIP 3	DIP 4
Frequency 1	ON	ON
Frequency 2	ON	OFF
Frequency 3	OFF	ON
Frequency 4	OFF	OFF

8. FLAT BATTERY

The battery life is of about 2 years (5 years in power save modality). The transmitter keeps constantly under control the state of its batteries. When the tension gets down under a pre – set value, this state is signaled to the associated receiver which signals it (if the buzzer is active) with 4 BEEP. If the battery is not substituted, the receiver will continue to regularly work until the tension of the batteries won't get down under the minimum safety threshold. If this happens, the receiver will signal it with **5 BEEP putting itself in state of alarm**.

The device will remain in state of alarm until the battery of the transmitter won't be substituted.

The substitution of the battery must be carried out by qualified personnel being necessary to open the receiver.

9. RECEIVER RESET

Through to the button present on the receiver it is possible, further than to carry out the programming of the transmitters (see section 5), to carry out the reset of the device deleting all the associated transmitters. Proceed as follows to carry out the reset:

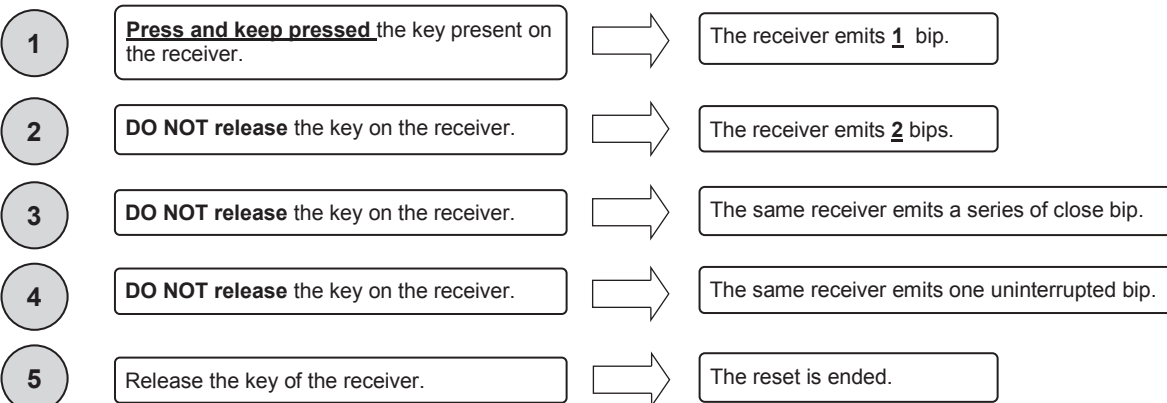

10. PROGRAMMING / TEST KEY OF THE TRANSMITTER

On each transmitter a key said "programming/test key" is present and a led. The pressure of the same key during the normal functioning (so not in programming) produces a signal that is sent to the receiver which close the contact of the relay and answers to this signal with:

Acoustic signaling during the normal functioning		
Number of BIP / BLINK	Meaning	What to do
1	Regular functioning, no mistake found.	-
2	One or more sensitive edge on alarm	Check the sensitive edges connected
3	One or more 8K2 safety sensitive edges under deactivated	Check the sensitive edges connected
4	Battery tension under the level of attention.	Substitute the batteries of the indicted device
5	Battery tension under the minimum level.	Substitute the batteries of the indicted device
6	One or more associated devices disconnected	Check each associated device

N.B.: If one transmitter is in alarm but it necessary to open or close the automation in any case, it's necessary to press and keep pressed the programming / test button of the indicted transmitter of the indicated and in the same time to move the automation.

WARNING: If the batteries are completely flat, it will be necessary to change them.

11. SAVING OF ENERGY (LOW POWER)

By the dip switch Low Power present on the transmitter device it is possible to limit the frequency with which the transmitter device transmits its state of functioning (period of interrogation): but in this case it will be necessary to keep in consideration the condition of dangerous that can be created if the power supply (battery) is taken off to the transmitter during the interval of time before the successive transmission of its state and successively the sensible edge goes on alarm: in this case the receiver will signal the alarm only after the period of interrogation.

With the dip 2 of the transmitter on OFF: energy saving deactivated, check the state of the transmitter each second (low power deactivated)
With the dip 2 of the transmitter on ON: energy saving activated, check state of transmitter each 15 seconds (low power activated)

12. DEVICES TEST

By the dip switch 1 of the receiver it is possible to select if the device test must be carried out with a high logic signal (so the test will activate itself if between the terminals TEST1 and TESTC will be present a tension from 10V dc to 24 Vdc) or with a low logic signal (so the test will activate itself if between the terminals TEST1 and TESTC will be present a tension of 0Vdc). In this case, the test will be for the device memorized to the relay 1. The same is for TEST2 and TESTC for the device memorized to the relay 2.

During this test, the receiver sends a signal to all the associated transmitter with the request of their state. If all the devices answer positively, the test is passed and the correspondent relay (which was previously open) re – closes itself.

With the dip 1 of the receiver on OFF position: the test of the device is executed by applying a high logic signal 10-24 Vdc at the input.
With the dip of the receiver on ON position: the test of the device is executed by applying a low logic signal 0 Vdc at the input.

Note : in case you don't want to use the test of the device, place the dip 1 on OFF position.

13 TECHNICAL FEATURES

Caratteristiche tecniche	Technical features	
Frequenza	Frequency	868,3 Mhz
Portata del sistema in campo libero	Range of the system in free space	30 m
Alimentazione trasmettitore	Transmitter power supply	2 batterie / battery AA
Alimentazione ricevitore	Receiver power supply	12/24 Vac-dc
Durata batteria	Battery duration	2 anni (modalità funzionamento normale) 5 anni (modalità risparmio energetico) 2 years (normal functioning mode) 5 years (power saved mode)
Coste compatibili	Compatible ribs	Meccaniche e/o 8,2K Mechanical and/or 8,2K
Numero di uscite	Number of output	2
Numero di costa associabili per ogni ricevitore	Number of ribs for receiver	4 per ogni uscita. 4 for each output.

WARNING:

TCO7TX DIP1 OFF: mechanical safety edge (normally closed contact)

This application does not comply with the automatic doors security norm for use EN 12453 because the connection of the NON-resistive component connected to the transmitter is not checked.

GUARANTEE - In compliance with legislation, the manufacturer's guarantee is valid from the date stamped on the product and is restricted to the repair or free replacement of the parts accepted by the manufacturer as being defective due to poor quality materials or manufacturing defects. The guarantee does not cover damage or defects caused by external agents, faulty maintenance, overloading, natural wear and tear, choice of incorrect product, assembly errors, or any other cause not imputable to the manufacturer. Products that have been misused will not be guaranteed or repaired. Printed specifications are only indicative. The manufacturer does not accept any responsibility for range reductions or malfunctions caused by environmental interference. The manufacturer's responsibility for damage caused to persons resulting from accidents of any nature caused by our defective products, are only those responsibilities that come under European law.