



GATE 1 DG R2BF

With inverter module

CONTROL UNIT FOR SLIDING GATES

(Cod. 23001235)

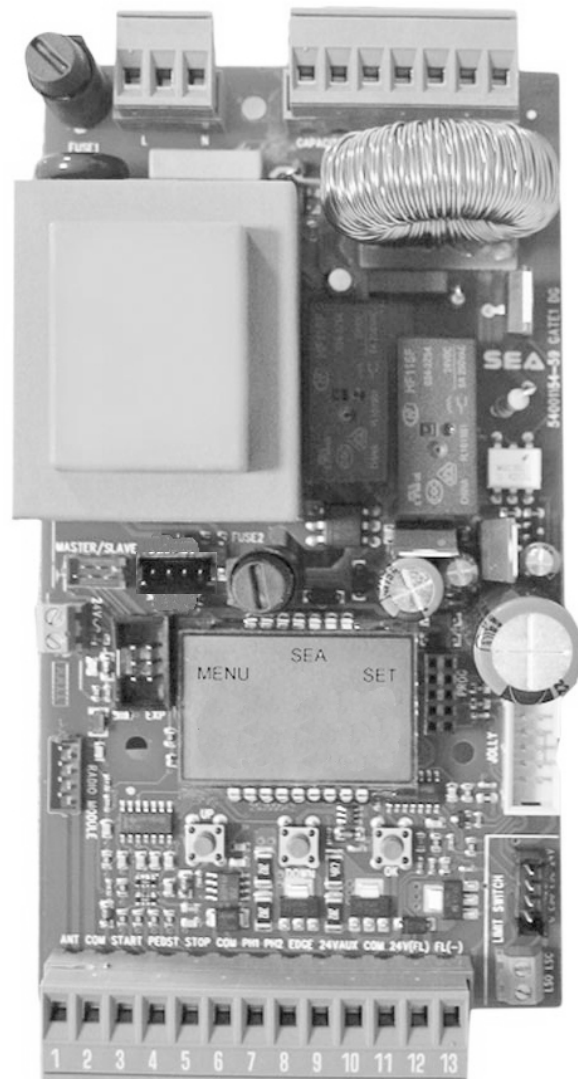

COMPONENTS

TECHNICAL SPECIFICATIONS

Control unit power supply: 230 Vac Single-phase
Absorption in stand by: 30 mA
Environment temperature : -20°C / +50°C
Specifications of external enclosure: 183 X 238 X 120 - IP55

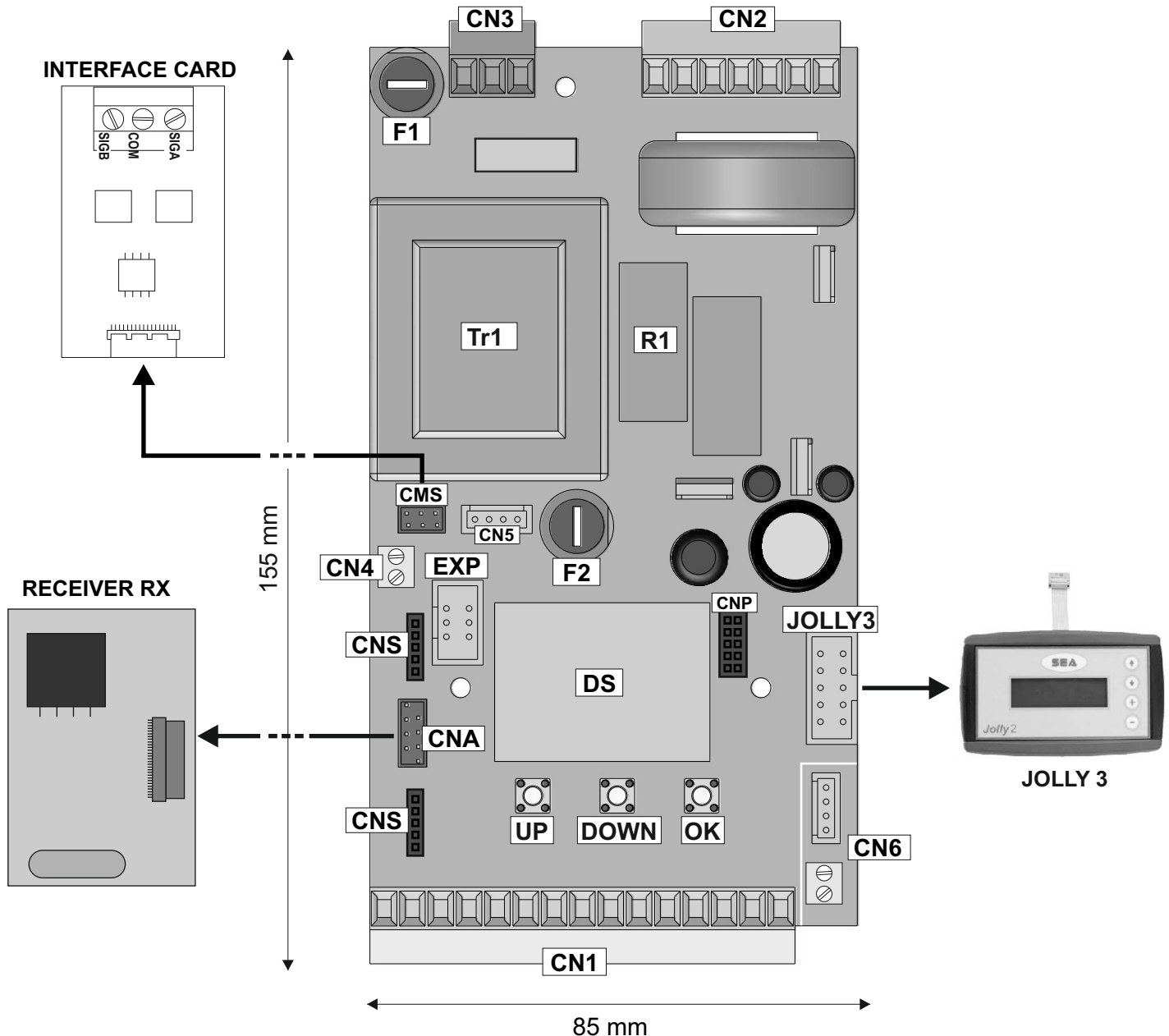

- CN1** = Input/output connectors
- CN2** = Courtesy light connector
- CN3** = Power connector
- CN4** = 24V~ connector
- CN5** = Inverter control connector
- CN6** = Limit switch connectors
- CNA** = Receiver connector RX
- CNP** = Programming connector
- CNS** = RF FIX Receiver connector
- EXP** = Expansion module connector - LSE card

- JOLLY 3** = Jolly 3 connector
- DS** = Programming display
- CMS** = Inverter interface connector
- OK** = Programming button
- DOWN** = Programming button
- UP** = Programming button
- R1** = Relay C motor command Courtesy light
- F1** = 6.3AT fuse on 230V
- F2** = Accessories 1A fuse
- Tr1** = Power transformer

CONNECTIONS

**RADIO MODULE RF FIX
(CNS)**

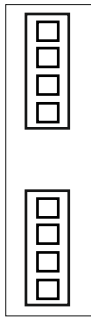

RF FIX
Receiver
connector

(Available from
hardware
revision R2)

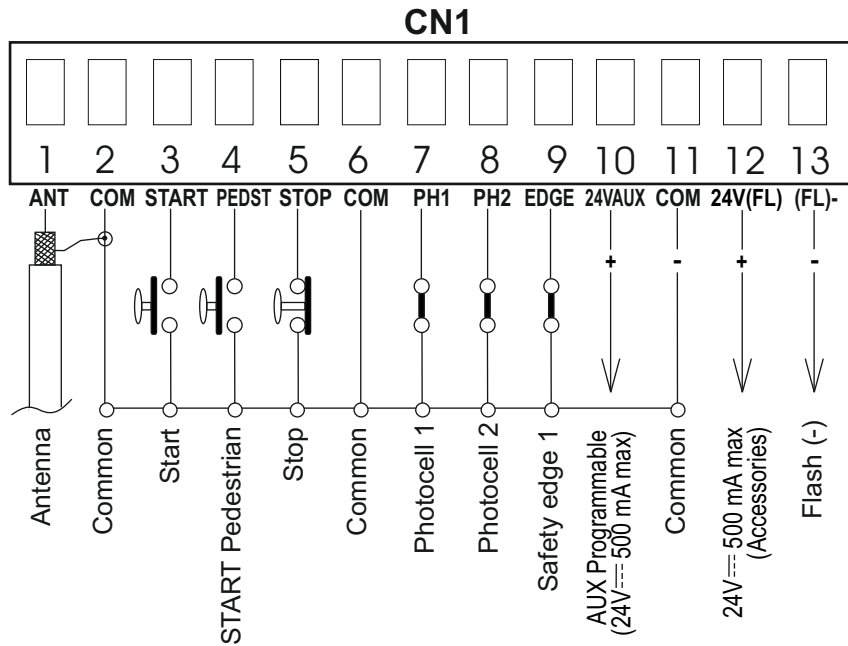
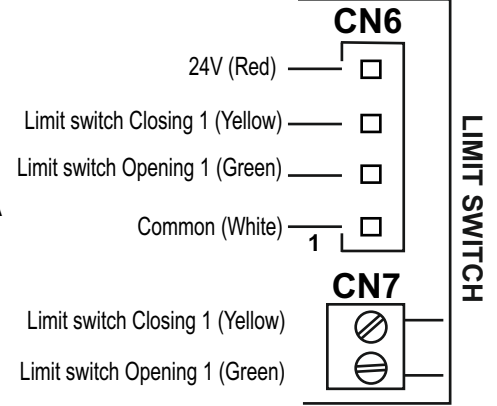
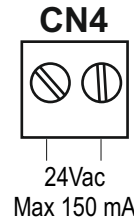
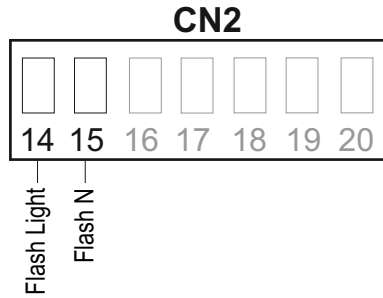

Note: The connectors CN6 and CN7 are not used if the Four limit switch interface card is connected.

JUMPERS

WARNING: The control unit is designed with the automatic detection of not used N.C. inputs (Photocells, Stop and Limit switch) except the SAFETY EDGE input. The exclude inputs in self-programming can be restored in the "Check inputs" menu without need to repeat the programming (page 11).

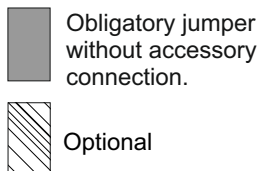
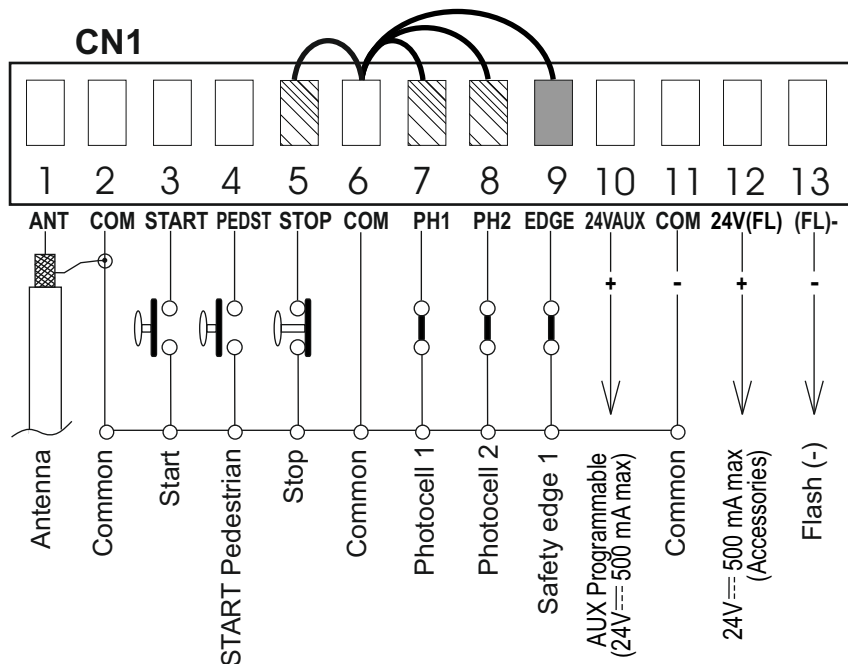

The herein reported
functions are
available starting
from: revision 01.07
compatible with
JOLLY3.

**PROGRAMMING
QUICK START**

**PROGRAMMING
BUTTONS**

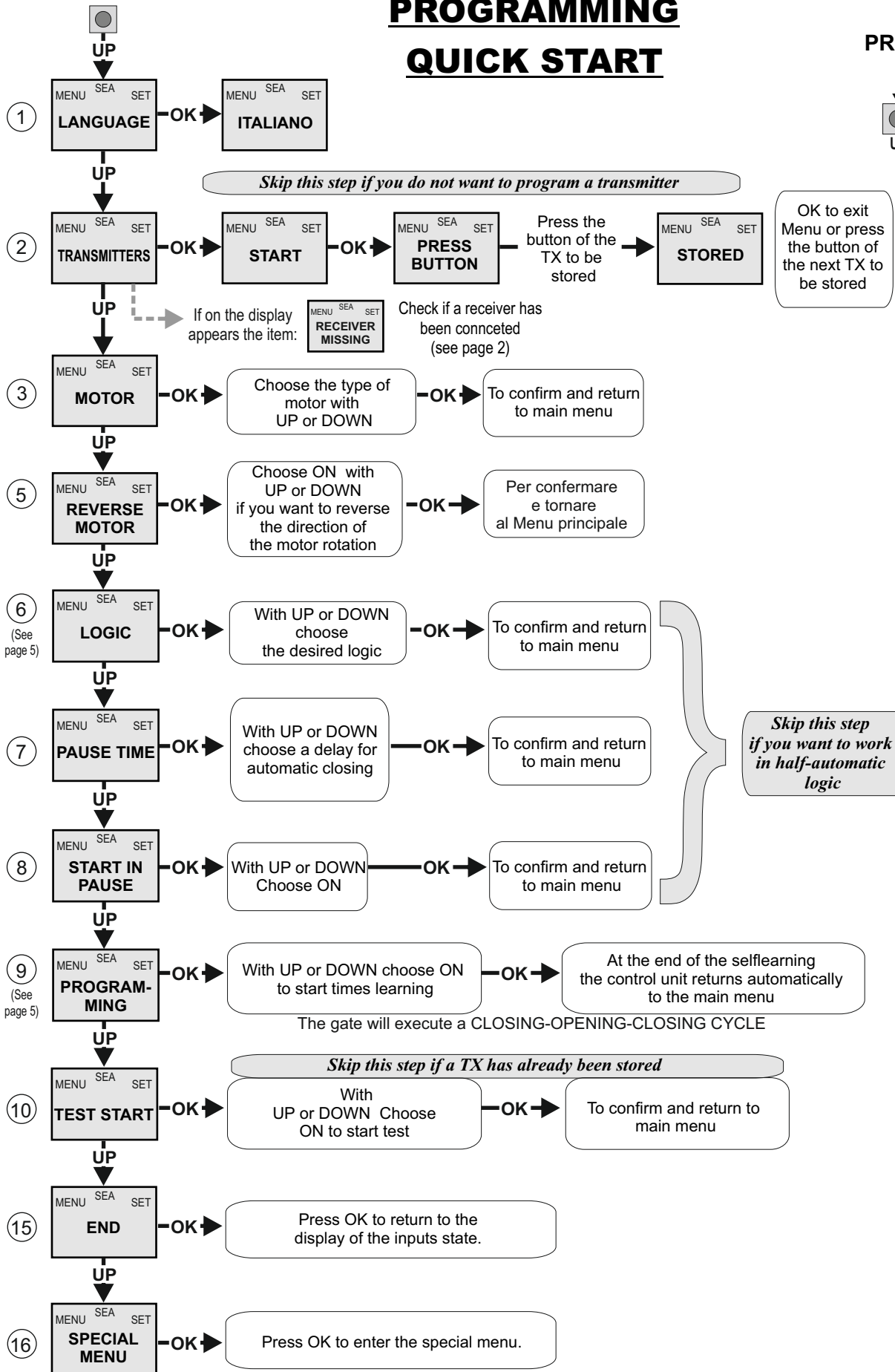
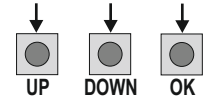

ALL OTHER PARAMETERS HAVE DEFAULT SETTINGS WHICH ARE USEFUL FOR THE 90% OF THE APPLICATIONS BUT CAN BE HOWEVER SET THROUGH THE SPECIAL MENU. FOR ENTERING INTO THE SPECIAL MENU MOVE ON ONE OF THE MENU AND PRESS THE UP AND DOWN BUTTONS AT THE SAME TIME FOR 5 S.

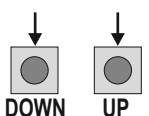

MENU FUNCTIONS TABLE GATE 1 DG R2BF				
MENU	SET	Description	Default	Set value
1 - LANGUAGE	<i>Italiano</i>	Italian	<i>English</i>	
	<i>English</i>	English		
	<i>Français</i>	French		
	<i>Español</i>	Spanish		
	<i>Dutch</i>	Olandese		
2 - TRANSMITTERS	<i>Start</i>	Start	<i>Start</i> <i>Pedestrian Start</i>	
	<i>Pedestrian Start</i>	Pedestrian Start		
	<i>External module</i>	External module		
	<i>Stop</i>	Stop		
	<i>Unloch</i>	Storing of a command for unlocking an electric brake		
	<i>Delete a transmitter</i>	Delete single transmitter		
	<i>Clear memory</i>	Delete transmitter memory		
	<i>End</i>	"Transmitters" menu output		
3 - MOTOR For single-phase version only	<i>Barrier</i>	<i>Barrier</i>	<i>Barrier</i>	
	<i>Centralina idraulica</i>	<i>Hydraulics units</i>		
	<i>Lepus Fast</i>	<i>Lepus Fast</i>		
	<i>Big Fast - Super Fast</i>	<i>Big Fast - Super Fast</i>		
	<i>Big</i>	<i>Big</i>		
3 - MOTOR For three-phase version only	<i>Sliding</i>	Sliding	<i>Sliding</i>	
	<i>Sliding Fast</i>	Sliding Fast		
5 - REVERSE MOTOR	<i>Off</i>	Synchronized right motor	<i>Off</i>	
	<i>On</i>	Synchronized left motor		
6 - LOGIC (See page 6)	<i>Automatic</i>	Automatic	<i>Automatic</i>	
	<i>Open-stop-close-stop-open</i>	Step by step type 1		
	<i>Open-stop-close-open</i>	Step by step type 2		
	<i>2 buttons</i>	Two buttons		
	<i>Safety</i>	Safety		
	<i>Dead man</i>	Dead man		
7 - PAUSE TIME	<i>Off</i>	OFF (semi-automatic logics)	<i>Off</i>	
	<i>1 240</i>	Setting from 1s to 4min.		
8 - START IN PAUSE	<i>Off</i>	In pause start is not accepted	<i>Off</i>	
	<i>On</i>	In pause start is accepted		
9 - PROGRAMMING (See page 6)	<i>Off On</i>	Times learning start	<i>Off</i>	
10 - TEST START	<i>Off On</i>	Start command	<i>Off</i>	
15 - END	Press OK to return to the display of the firmware version and to the one of inputs state.			
16 - SPECIAL MENU	Press OK to enter the special menu.			

Note: In case of three-phase version, the motors are: "*Sliding*" and "*Sliding Fast*".

WORKING TIMES SELF LEARNING

- 1) Turn off electricity, release the motors and manually position the leaves on halfway.
Reset the mechanical lock.
- 2) Connect the control board to the power supply.
- 3) Before starting the learning, make sure (through the test menu), that the relative limit switches of every opening are employed.
- 4) Select on the on-board display or JOLLY 3 programmer, the type of motor that you are using as indicated in the display management.
- 5) If necessary also set the operation logic and the other parameters. If you want to program with a transmitter, store a transmitter before programming.
- 6) Select 9-PROGRAMMING on the display, press OK and then one of the UP or DOWN buttons.
(If the motor starts in opening, remove and re-put power supply, select on the display 5-REVERSE MOTOR.
And through the UP and DOWN button put it on ON, or if you have the Jolly 3 programmer, activate the motor exchange function.)
- 7) At this point the gate will start the following cycle: CLOSING - OPENING - CLOSING.

FUNCTION LOGIC

AUTOMATIC LOGIC

A start impulse opens the gate. A second impulse during the opening will not be accepted.

A start impulse during closing reverses the movement.

NOTE 1: To have the automatic closing it is necessary to set a pause time, otherwise all the logic will be semi-automatic.

NOTE2: It is possible to choose, whether to accept or not, the start in pause, selecting in the MENU the item 8-START IN PAUSE and choosing ON or OFF. By default, the parameter is OFF.

SECURITY LOGIC

A start impulse opens the gate. A second impulse during opening reverses the movement.

A start impulse during closing reverses the movement.

NOTE 1: To have the automatic closing it is necessary to set a pause time, otherwise all the logic will be semi-automatic.

NOTE2: It is possible to choose, whether to accept or not, the start in pause, selecting in the MENU the item 8-START IN PAUSE and choosing ON or OFF. By default, the parameter is OFF.

STEP BY STEP TYPE 1 LOGIC

The start impulse follows the OPEN-STOP-CLOSE-STOP-OPEN logic.

NOTE 1: To have the automatic closing it is necessary to set a pause time, otherwise all the logic will be semi-automatic.

NOTE2: It is possible to choose, whether to accept or not, the start in pause, selecting in the MENU the item 8-START IN PAUSE and choosing ON or OFF. By default, the parameter is OFF.

STEP BY STEP TYPE 2 LOGIC

The start impulse follows the OPEN-STOP-CLOSE -OPEN logic.

NOTE 1: To have the automatic closing it is necessary to set a pause time, otherwise all the logic will be semi-automatic.

NOTE2: It is possible to choose, whether to accept or not, the start in pause, selecting in the MENU the item 8-START IN PAUSE and choosing ON or OFF. By default, the parameter is OFF.

DEAD MAN LOGIC

The gate opens as long as the **START** button of opening is pressed; releasing it the gate stops. The gate closes as long as the button connected to the **PEDESTRIAN START** is pressed; releasing it the gate stops. To execute complete opening and/or closing cycles the related pushbuttons must be constantly pressed.



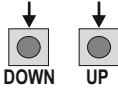

2 PUSHBUTTONS LOGIC

One start opens, one pedestrian start closes. In opening the closing will not be accepted. In closing a start command reopens, a pedestrian start command (closes) will be ignored.



SPECIAL MENU

PRESS AT THE SAME TIME FOR 5 SECONDS TO ENTER OR TO EXIT THE SPECIAL MENU

SPECIAL MENU FUNCTIONS TABLE GATE 1 DG R2BF INVERTER				
For entering into the special menu move on one of the menu and press the UP and DOWN buttons at the same time for 5 s. For exiting the special menu press END or move on one of the menu and press the UP and DOWN buttons at the same time for 5 s.				
MENU SP	SET	Description	Default	Set Value
17 - OPENING SPEED	10 100	Setting from 10 to 100	80	
18 - CLOSING SPEED	10 100	Setting from 10 to 100	80	
21 - OPENING SLOWDOWN SPEED 1	10 60 from max. speed	Slowdown speed in opening	20	
22 - CLOSING SLOWDOWN SPEED 1	10 60 from max. speed	Slowdown speed in closing	20	
28 - OPENING A THRESHOLD * For three-phase version only	1 - 5	Adjust inversion current on motors in opening.	2.5	
29 - CLOSING A THRESHOLD * For three-phase version only	1 - 5	Adjust inversion current on motors in closing.	2.5	
32 - ENCODER *	Potentiometer	Enables the reading of the potentiometer with LE card.	Off	
	51 - I.PAR.M1 *	-----		
	52 - I.AP.M1 *	-----		
	53 - I.CH.M1 *	-----		
32 - ENCODER *	On	In ON enables the Encoder	Off	
47 - ENCODER PAR.1 *	xxx.	Encoder impulses during operation (Motor 1).		
48 - ENCODER TOT.1 *	xxx.	Encoder impulses stored in programming (Motor 1).		
32 - ENCODER *	Off	In OFF disabled the Encoder	Off	
33 - OPENING SENSITIVITY MOTOR1	10% (Fast intervention) 99% (Slow intervention)	Adjusts the intervention time of the Encoder / Potentiometer in opening	95	
	Off (Intervention excluded)	Disabled		
34 - CLOSING SENSITIVITY MOTOR1	10% (Fast intervention) 99% (Slow intervention)	Adjusts the intervention time of the Encoder / Potentiometer in closing	95	
	Off (Intervention excluded)	Disabled		
57 - WORKING CURRENT	0.0A	Shows motor absorption during operation		
59 - OPENING SLOWDOWN 1	Off 50	From OFF to 50% of the stroke. Note: Not active if the Four limit switch interface card is present	30	
60 - CLOSING SLOWDOWN 1	Off 50	From OFF to 50% of the stroke. Note: Not active if the Four limit switch interface card is present	30	

MENU SP	SET	Description	Default	Set Value
63 - DECELERATION	0 %  100% 	Adjust the passage between normal speed and slowdown speed	50%	
64 - ACCELERATION	1 s  5 s 	Acceleration ramp. Adjusts the motor start.	2.5 s	
70 - POSITION RECOVERY (For three-phase version only)	0 20 s	Retrieves the inertia of the motor in opening and closing after Stop or reversing	1 s	
79 - ANTI INTRUSION	Only opening	If you force the gate manually, the control unit starts the motor to restore the state of the gate before forcing.	Off	
	Only closing			
	Opening and closing			
	Off			
85 - PREFLASHING	Only closing	Pre-flashing only active before closing	Off	
	0.0 5.0	Pre-flashing time		
86 - FLASHING LIGHT	Normal	Normal	Normal	
	Light	Control lamp		
	Always	Always ON		
	Buzzer	Buzzer		
87 - FLASHING LIGHT AND TIMER	Off	The flashing light remains OFF with the active timer and open gate	Off	
	On	The flashing light remains ON with active timer and open gate		
88 - COURTESY LIGHT	In cycle	Courtesy light in cycle	20	
	1 240	Courtesy light setting from 1s to 4min.		
89 - TRAFFIC LIGHT RESERVATION	Off on	When setting this function the pedestrian input will be activated to work on the auxiliary board SEM (traffic light management).	Off	
90 - PARTIAL OPENING	5 100%	Setting from 5 to 100	100%	
91 - PARTIAL PAUSE	= Start	Pause in partial opening same as in total opening	= Start	
	Off	Disabled		
	1 240	Setting from 1s to 4 min.		
92 - TIMER	Off	Transforms the selected input in an input on which to connect an external clock.	Off	
	On photo2			
	On pedestrian entry			
93 - FIRE SWITCH	Off	Disabled	Off	
	On photo2	Active on Photo 2		
	On pedestrian entry	Active on pedestrian		

MENU SP	SET	Description	Default	Set Value
94 - 24V AUX (Programmable)	<i>Always</i>	AUX output always power supplied	<i>Always</i>	
	<i>In cycle</i>	AUX output active only during cycle		
	<i>Opening</i>	AUX output power supplied only during opening		
	<i>Closing</i>	AUX output power supplied only during closing		
	<i>In pause</i>	AUX output power supplied only during pause		
	<i>Autotest</i>	Security test		
	<i>In cycle and fototest</i>	AUX output only during cycle with fototest function active		
95 - AUTOTEST	<i>Photo1</i>	Autotest active only on Photo1	<i>Off</i>	
	<i>Photo2</i>	Autotest active only on Photo2		
	<i>Photo1-2</i>	Autotest active on Photo1 and Photo2		
	<i>Off</i>	Disabled		
	<i>Edge</i>	Autotest only on safety edge		
	<i>Photo1 and Edge</i>	Autotest photo 1 and safety edge		
	<i>Photo2 and Edge</i>	Autotest photo 2 and safety edge		
	<i>All safe</i>	Autotest photo 1, photo 2 and safety edge		
97 - PHOTO1	<i>Closing</i>	Photocell active in closing	<i>Closing</i>	
	<i>Opening</i>	Active in opening and closing		
	<i>Stop</i>	Photocell active before opening		
	<i>Stop and close</i>	The photocell stops in closing and closes when released		
	<i>Close</i>	The photocell gives a command to close during opening, pause and closing		
	<i>Pause reload</i>	The photocell charging the pausing time		
	<i>Shadow loop</i>	Until occupied, with open gate, it prevents reclosing. It is switched off during closing.		
98 - PHOTO2	<i>Closing</i>	Photocell active in closing	<i>Opening</i>	
	<i>Opening</i>	Active in opening and closing		
	<i>Stop</i>	Photocell active before opening		
	<i>Stop and close</i>	The photocell stops in closing and closes when released		
	<i>Close</i>	The photocell gives a command to close during opening, pause and closing		
	<i>Pause reload</i>	The photocell charging the pausing time		
	<i>Shadow loop</i>	Until occupied, with open gate, it prevents reclosing. It is switched off during closing.		

MENU SP	SET	Description	Default	Set Value
100 - EDGE1	<i>Normal</i>	Normal N.C. contact	<i>Normal</i>	
	<i>8K2</i>	Edge is active and protected by a 8k2 resistor		
102 - EDGE1	<i>Opening and closing</i>	Active in opening and closing	<i>Opening and closing</i>	
	<i>Only opening</i>	Active only in opening		
	<i>Only closing</i>	Active only in closing		
104 - SELECT LIMIT SWITCH	<i>Normal</i>	Limit switch in automatic recognition	<i>Normal</i>	
	<i>Ext</i>	With LSE card		
106 - DIAGNOSTICS	<i>1 10</i>	Shows last event (See alarms table)		
107 - MAINTENANCE CYCLES	<i>100 10E4</i>	Setting from 100 to 100000	<i>10E4</i>	
108 - PERFORMED CYCLES	<i>0 10E9</i>	Reports the executed cycles. Keep pressed OK to reset the cycles	<i>0</i>	
112 - PASSWORD	<i>----</i>	Allows the entering of a password blocking the control unit parameters modification.	<i>----</i>	
115 - DECELERATION RAMP	<i>1 s</i> 	Adjust the motor stop. On heavy gates it is recommended to set this value to minimies 2.5s.	<i>----</i>	
	<i>5 s</i> 			
120 - BASIC MENU	Press OK to exit the special menu. The special menu switches off automatically after 20 minutes.			

Note 1: The * indicates that the default value or the menu may change depending on the selected motor type.

Note 2: After initialization the parameters "motor type" and "limit switch type" remain son the value chosen in the setup program.

PASSWORD ENTERING MANAGEMENT

With a new control unit all menus can be displayed and set and the password will be disabled.

Selecting one of the Menus and keeping UP and DOWN pressed at the same time for 5 seconds, you will access the SP Menu containing the 112-PASSWORD Submenu.

Pressing OK in the 112-PASSWORD Menu, you will proceed with the entering of the numeric code of the 4-digit password.

Use UP and DOWN to increase or decrease the number, press OK to confirm it and you will pass automatically to the entering of the next number. Pressing OK after the last entered number the word "Sure?" appears, confirm the activation of the password and the message OK appears, pressing UP or DOWN instead you can cancel the operation and "No operation" will appear on the display.

Once entered the password, it will be definitively activated, once the display switch off timeout has expired, or by turning off and on again the control unit. Once the password has been activated, the menus of the display can be only displayed but not set. To unlock them you must enter the correct password in the 112-PASSWORD menu, if the password is wrong the message "Error" will appear.

At this point, if the password has been entered correctly, the menus will be unlocked and it will be possible to change the parameters of the control unit again.

If the control unit has been unlocked through 112-PASSWORD Menu, it is possible to enter a new and different password, using the same entering process as for the first one; at this point, the old password will no longer be valid.

If the password has been forgotten, the only way to unlock the control unit is to contact the SEA technical assistance, which will assess whether to provide the procedure to unlock the control unit or not.

Note: The password cannot be set through the Jolly 3 terminal.

MENU FOR INPUT CHECK

The settings of the control unit are made through the UP, DOWN and OK buttons. The UP and DOWN buttons to scroll through the MENUS and SUBMENUS. By pressing OK you enter from MENU into SUBMENU and confirm the choice.

Moving in the 1-LANGUAGE menu pressing the UP and DOWN buttons at the same time you access the SP MENU for special settings.

Moving in the 1-LANGUAGE menu pressing the OK button for 5 seconds, you enter the CHECK MENU, where you can check the operating status of all inputs.

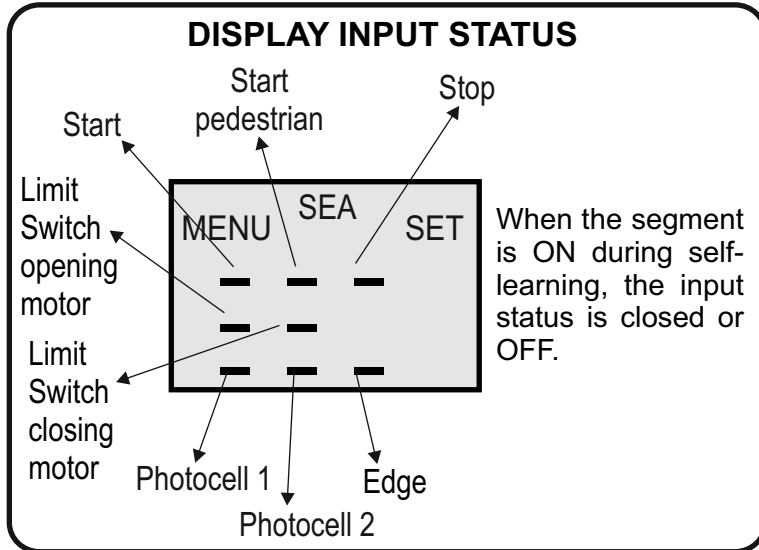

Initial system

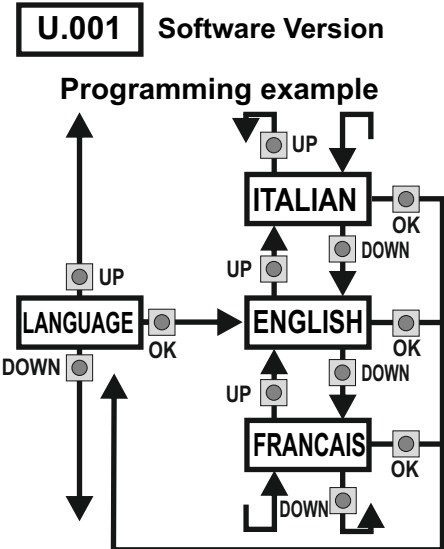

MENU FUNCTION TABLE CHECK GATE 1 DG R2BF INVERTER INPUTS		
To access the Menu for input check keep pressed OK for about 5 seconds.		
MENU	Description	Description
START	Start test	The contact must be a N.O. Contact . When activating the related command on the display SET lights up, the input works. If SET is always on, check the wirings.
STOP → OK ↘	Enabled Blocked	Stop test
PEDESTRIAN START	Pedestrian start test	The contact must be a N.O. Contact. When activating the related command on the display SET lights up, the input works. If SET is always on, check the wirings.
EDGE1 → OK ↘	Enabled Blocked	Safety edge test
PHOT01 → OK ↘	Enabled Blocked	Photocell 1 test
PHOT02 → OK ↘	Enabled Blocked	Photocell 2 test
LIMIT SWITCH OPENING	Opening limit switch test	The contact must be a N.C. Contact. When activating the related command on the display SET lights up, the input works. If SET is always on, make sure that the contact is a N.C. contact or that the related limit switch is not occupied.
LIMIT SWITCH CLOSING	Closing limit switch test	The contact must be a N.C. Contact. When activating the related command on the display SET lights up, the input works. If SET is always on, make sure that the contact is a N.C. Contact or that the related limit switch is not occupied.
END		Exit menu

Note: If the Stop, Photocell 1 and Photocell 2 contacts are not bridged in self-learning, they will be deactivated and can be reactivated through this menu, without repeating times self-learning.

RADIO TRANSMITTER SELF LEARNING

WITH RECEIVER ON BOARD OF CONTROL UNIT

⚠ WARNING: Make the radio transmitters programming before you connect the antenna and insert the receiver into the special CMR connector (if available) with turned off control unit.

With RF UNI and RF UNI PG module it will be possible to use both Coccinella Roll Plus transmitters and radio transmitters with fixed code. The first memorized radio transmitter will determine the type of the remaining radio transmitters.

If the receiver is a **Rolling Code**, press **twice** the button of the radio transmitter that you want to program to memorize the first TX.

In the case of **transmitters with fixed code** it is necessary to **press 1 time** the button of the transmitter you want to program to store the first remote control

- Notes:**
- Enter radio transmitters learning only when the working cycle stops and the gate is closed.
 - You can store max. 2 of the available 4 functions. If the control unit receives a code which was already associated to another function it will be updated with the new function.

RF UNI	16 USERS Whitout memory 800 USERS With additional memory MEMO
RF UNI PG <i>Old model without additional memory</i>	100 USERS Fixed code 800 USERS Roll Plus
RF UNI PG <i>New model with MEMO additional memory</i>	800 UTENTI Fixed code 800 UTENTI Roll Plus 

TABLE EXAMPLE

Transmitter Memory location	1	2	3	4	Serial number	Customer
0						
1						
2						
3						

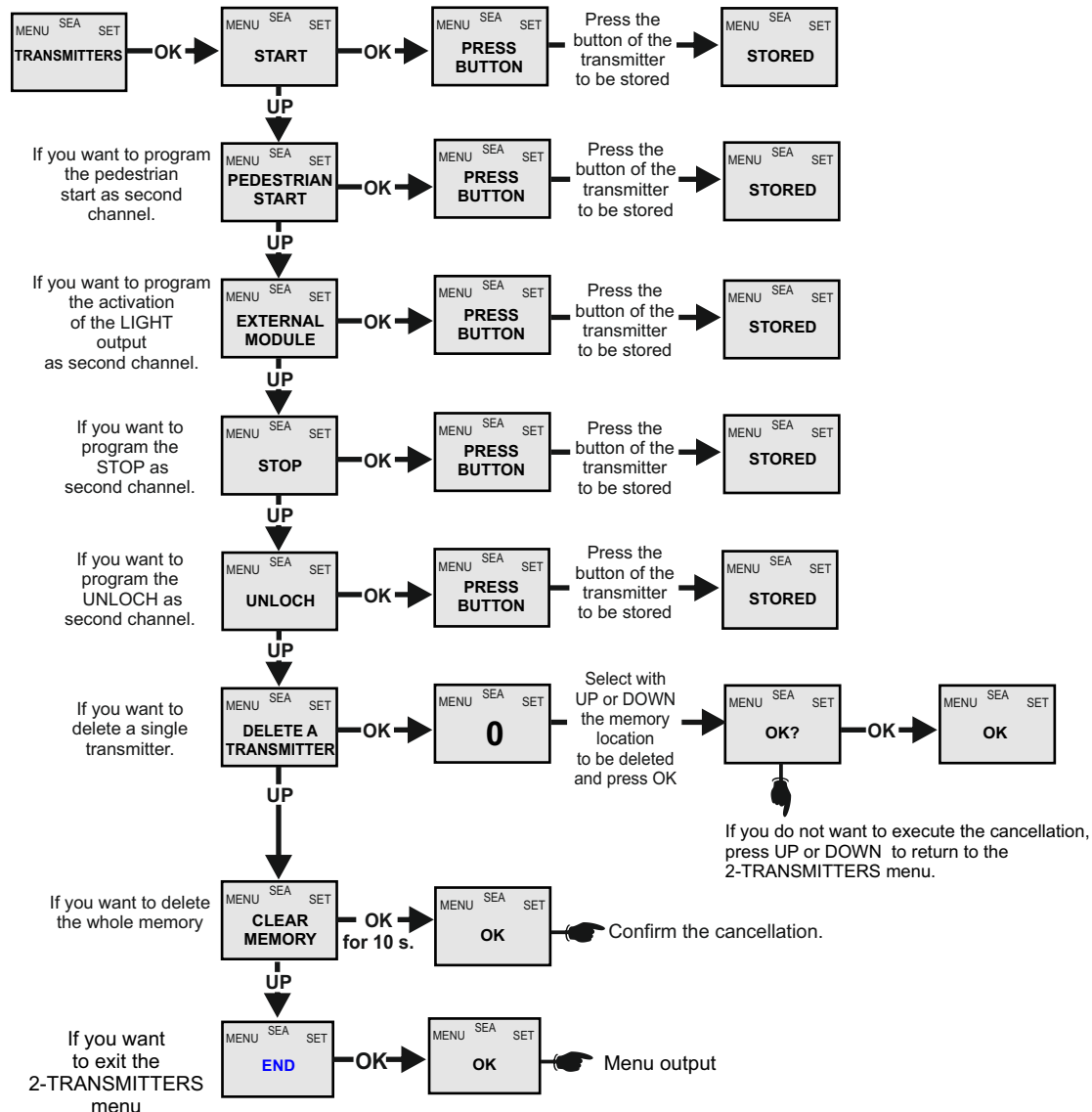

RADIO TRANSMITTER SELF LEARNING

WITH RF FIX RECEIVER ON BOARD OF CONTROL UNIT

⚠ WARNING: Make the radio transmitters programming before you connect the antenna and insert the receiver into the special CNS connector (if available) with turned off control unit.

With the RF FIX module it will be possible to use only radio controls with fixed code.

Select through the display 2-TRANSMITTERS and press OK, now select with the UP and DOWN buttons, the command to which you want to associate the button (it is possible to associate max. 2 commands) and press OK to confirm the choice, now press the button of the radio transmitter which you want to associate. If the storage is successful, the display will show "Stored".

In the 2-TRANSMITTERS MENU it is possible to select "Start" (to associate a Start command), "Pedestrian start" (to associate a Pedestrian Start), "External Module" (For the activation of a contact on the EXP output), "Stop" (To associate the STOP command to the TX), "Unloch" (to associate the release of the electric brake to the transmitter), "Delete a transmitters" (To delete the single transmitter only if it is a Rolling Code Plus), "Clear memory" (To delete all TX), "End" (To exit menu 2-TRANSMITTERS). To release the electric brake it is necessary to give three consecutive pulses, the 4th will reactivate the lock of the electric brake.

Notes:

- Enter radio transmitters learning only when the working cycle stops and the gate is closed.
- It will be possible to memorize up to max. 16 codes (buttons) adding the MEM memory it will be possible to store up to 496 different codes.
- You can store max. 2 of the available 4 functions. If the control unit receives a code which was already associated to another function it will be updated with the new function.

DELETE TRANSMITTERS FROM THE RECEIVER

With modules different from RF FIX, it will be possible to delete only the entire memory of the receiver.

Proceed as follows: select from the menu 2-TRANSMITTERS: "Clear memory" and hold the OK button until the display shows the message "OK".

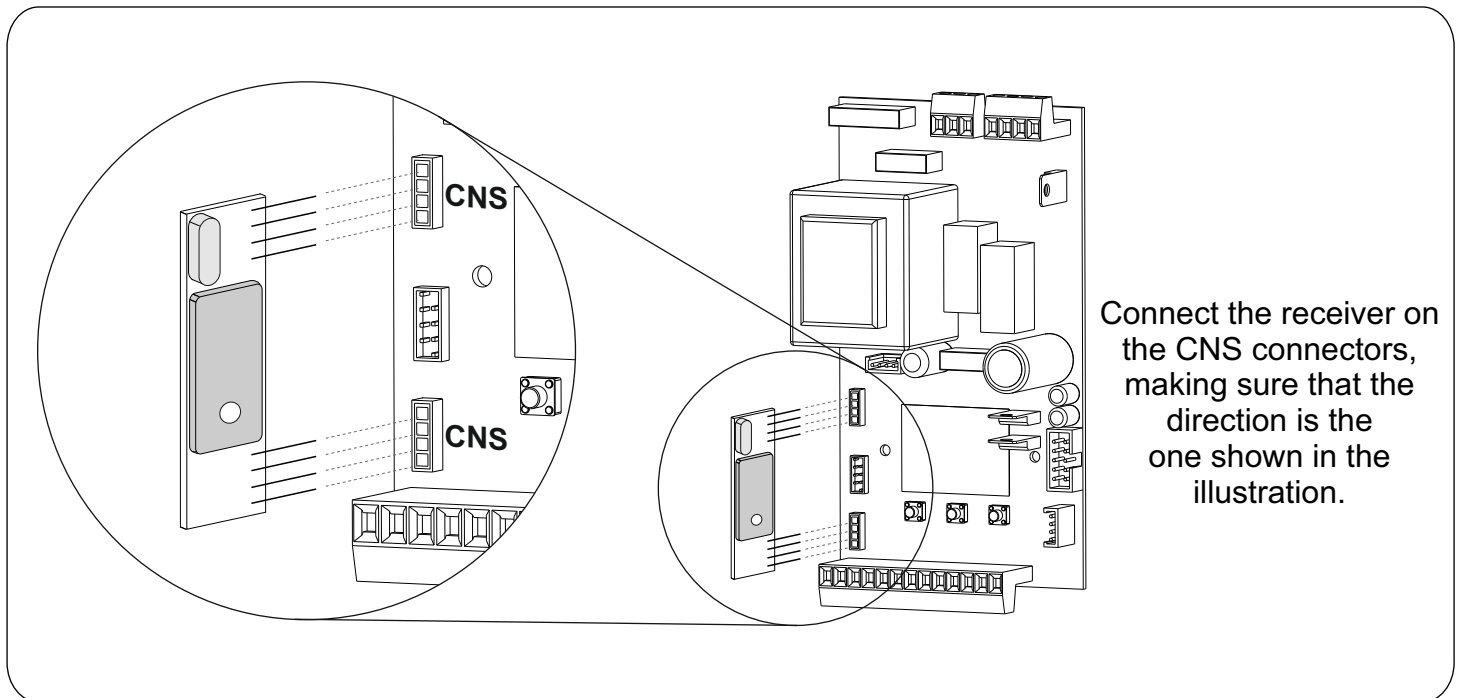

**START - STOP - PEDESTRIAN START - ANTENNA -
PHOTOCELL**

Photocell 1 and Photocell 2 Connections

Note: If the photocells are not connected, it is not necessary put a jumper between the clamps (6 and 7 and/or 6 and 8 of the CN1 terminal)

+ = 24V === (Accessories) 500 mA max COM = 0V PH1 = Photocell contact 1

PH2 = Photocell contact 2

Note: For the autotest connect the TX to the AUX clamp and activate the Autotest function.

The default setting of the photocell 1 is in "Closing" and the one of the photocell 2 is in "Opening".

The photocell 2 can also be set as TIMER (see TIMER function).

OPTIONS ON FOTO1 and FOTO2 adjustable on on-board display or with Jolly 3 terminal.

"Closing": if occupied, reverses the movement in closing, during pause it prevent the closing.

"Opening": If activated the photocell blocks the movement as long as it's busy, when released the opening continues.

"Stop": When activated before the opening the photocell blocks the automation as long as it is busy, during the opening it will be ignored. In closing the intervention of the photocell causes the reopening.

"Stop and close": in opening it is not active; in pause are activated it commands the closing when released, otherwise it's not active; in closing it stops the movement as long as it is busy, when released the closing continues.

"Close": The photocell stops the gate as long as it is occupied in both opening and closing, when released it gives a closing command (Closing one second after release of the photocell).

"Pause reload": If occupied, during pause it recharges the timer of pause. In closing it reverses the movement.

"Shadow loop": Photocell active only during pause.

"Delay pause time": If the photocell is occupied during opening, pause or closing, the gate reopens completely and closes without observing the pause time.

Options AUX 24V === 500mA (Programmable) max can be set with on-board Display or with Jolly 3 device. It is possible to chose when having tension on the AUX output. The options are: **Always, In cycle, Opening, Closing, In pause, Autotest, In cycle and fototest, Positive brake management, Negative brake management, Negative brake management-photocellule, Gate open warning light, Lock, Opening and open.**

PEDESTRIAN START (N.O.) The pedestrian start can be connected between the connectors 2 and 4 of the CN1 terminal.

This input allows a partial opening, the opening space can be set through the on-board display or through the JOLLY 3 device.

Note1: The contact for partial opening is a N.O. Contact (Normally open). Holding START starts the TIMER function, releasing the pedestrian start, the operator repeats the pause and then performs the closing. In the case of triggering a safety device the timer will automatically reset after 6 seconds.

Note2: In 2 BUTTONS logic it is necessary to keep pressed the Start Ped. to re-close the automation.

Note3: In deadman logic this button executes the re-closing if you keep it pressed.

Note4: When closed during pause, the gate will reclose only after this input has been reopened.

TIMER activation: This input can be transformed into TIMER (See TIMER).

Nota5: When using the Sem card, the pedestrian input can be used as priority in closing through the 89-TRAFFIC LIGHT RESERVATION function.

STOP (N.C.) The STOP is connected between the clamps 2 and 5 of the CN1 terminal.

When pressing this button the motor immediately stops in any condition/position. To re-start the movement give a start command. After a stop the motor always re-starts in closing.

START (N.O.) The START is connected between connector 2 and 3 of the CN1 terminal.

An impulse given to this contact opens and closes the automation depending on the selected logic, it can be given by a keyswitch, a keypad, etc. Holding START starts the TIMER function, releasing the start, the operator repeats the pause and then performs the closing.

To connect the other devices refer to the related instructions leaflets. (ie. loop detectors and proximity switches). In the case of triggering a safety device the timer will automatically reset after 6 seconds.

Note1: In DEADMAN logic keep pressed the Start for the opening of the automation.

Note2: In 2 BUTTONS logic this button performs the opening.

TIMER



Can be activated through the on-board display or through the Jolly 3 programmer. In both cases it's a N.O. contact which provokes the opening of the automation keeping it open as long as it is activated. When it's released, after having paused for the set pausing time the gate recloses. The TIMER can be activated on the inputs FOTO2, PEDESTRIAN START or keeping busy the START input.

Note1: When activated on the pedestrian entry, the pedestrian will be OFF also on the radio transmitter.

Note2: In the event of an intervention of a security device during the timer (Stop, amperometric, Edge), a start impulse restores the movement.

Note3: In case of no power supply with open gate and active Timer the control unit will restore its function, otherwise if during restoring of the power supply the TIMER is not activated it will be necessary to give a start impulse for the reclosing.

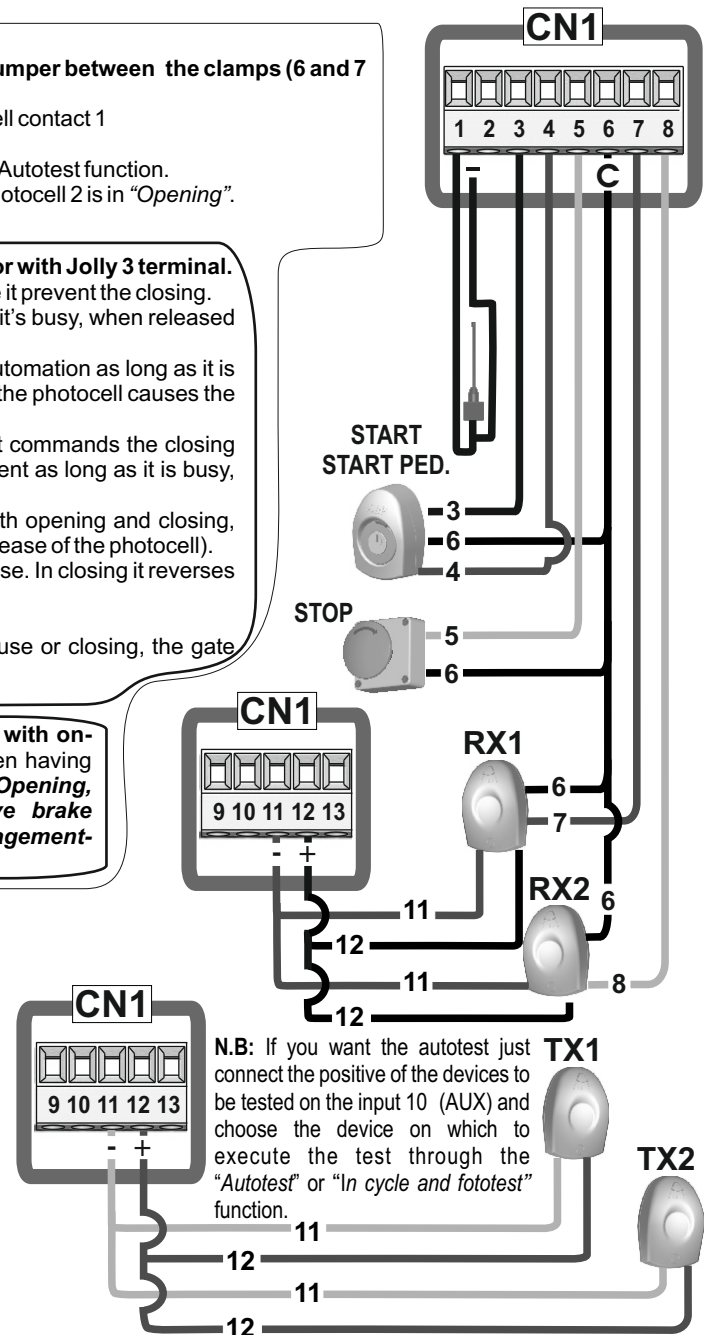

N.B: If you want the autotest just connect the positive of the devices to be tested on the input 10 (AUX) and choose the device on which to execute the test through the "Autotest" or "In cycle and fototest" function.

AMPEROMETRIC MANAGEMENT

AMPEROMETRIC DEVICE FOR ELECTROMECHANICAL OPERATORS

This control unit comes with an obstacle detection system working only on electromechanical operators allowing to have the reversing on obstacles and the automatic detection of the stops.

Sensitivity adjustable from OFF to 99% inside the special menu. The more the percentage is high the more the obstacle detection will be difficult.

ENCODER (CN5 Connector)

The Encoder allows the detection of the gate position and its reversing in case of obstacles. To use the ENCODER it is necessary to enable it inside the special 32-ENCODER Menu. The sensitivity on the obstacle is adjustable from 0 - 99%. The higher the percentage is the more it will be difficult to detect the obstacle.

NOTE: If the Encoder is activated it is possible to visualize in the special menu the total memorized impulses and the partial impulses executed by the motor.

POTENTIOMETER "GATE POSITION"

If the POSITION GATE is present on hydraulic motors it will be possible to have the inversion on obstacles by adjusting the menus 33- MOTOR1 OPENING SENSITIVITY, 34- MOTOR1 CLOSING SENSITIVITY, 37- SLOWDOWN SENSITIVITY.

ATTENTION: The first operation, after power failure will be for searching the mechanical stops at the end of the run.

SAFETY EDGE AND FLASHING LAMP

SAFETY EDGE

Safety edges (EDGE) can be connected between the contacts 9 and 11 of CN1.

Pressing EDGE, the contact opens, causing a partial reversing of the gate in closing and opening.

Note1: If the edge contact is not used it must be bridged. The EDGE input can be set: only in closing, only in opening or in both directions.

Note2: It is possible to activate a balanced edge 8K2 through the on board display or through the Jolly 3 programmer, in such case the edge contact will be controled by a specific resistance value, detecting the possible involuntary short circuit of the device. In case of an imbalanced device a special alarm will show on the on board display or on the JOLLY 3 programmer.

Note: it is possible to perform an Autotest also on the powered radio edge.

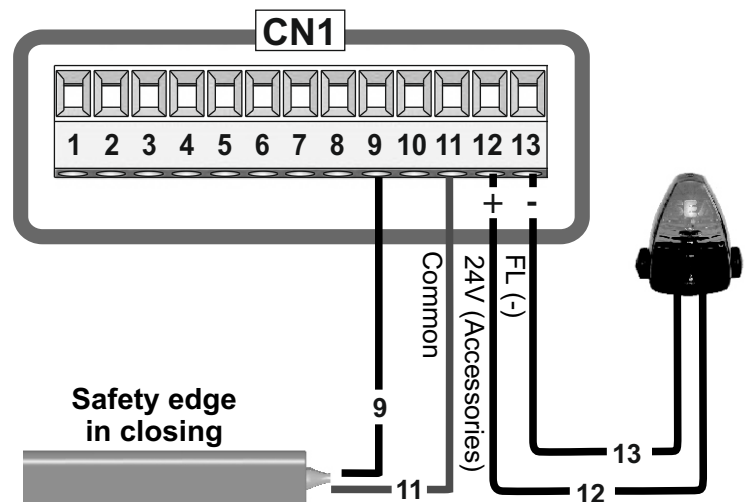

Warning lamp Flash Led 24V $\overline{\text{---}}$ (Accessories) 3W Max (Control lamp)

The warning lamp can be connected between the terminals 24V $\overline{\text{---}}$ (Accessories) and FL (-) of CN1. It blinks once per second during opening and twice per second during closing, while it remains lit during pause.

Through the warning lamp it is also possible to identify alarm signals coming from the STOP, PHOTOCELL 1, PHOTOCELL2 and EDGE devices. Through the on board display or the Jolly 3 programmer it is possible to activate the pre-flashing function and/or to modify the flashing light function choosing between fixed flashing, control lamp or Buzzer.

The pre-flashing can be set from 0 to 5 s. or it is possible to have it only before closing.

COURTESY LIGHT AND POWER SUPPLY CONNECTIONS

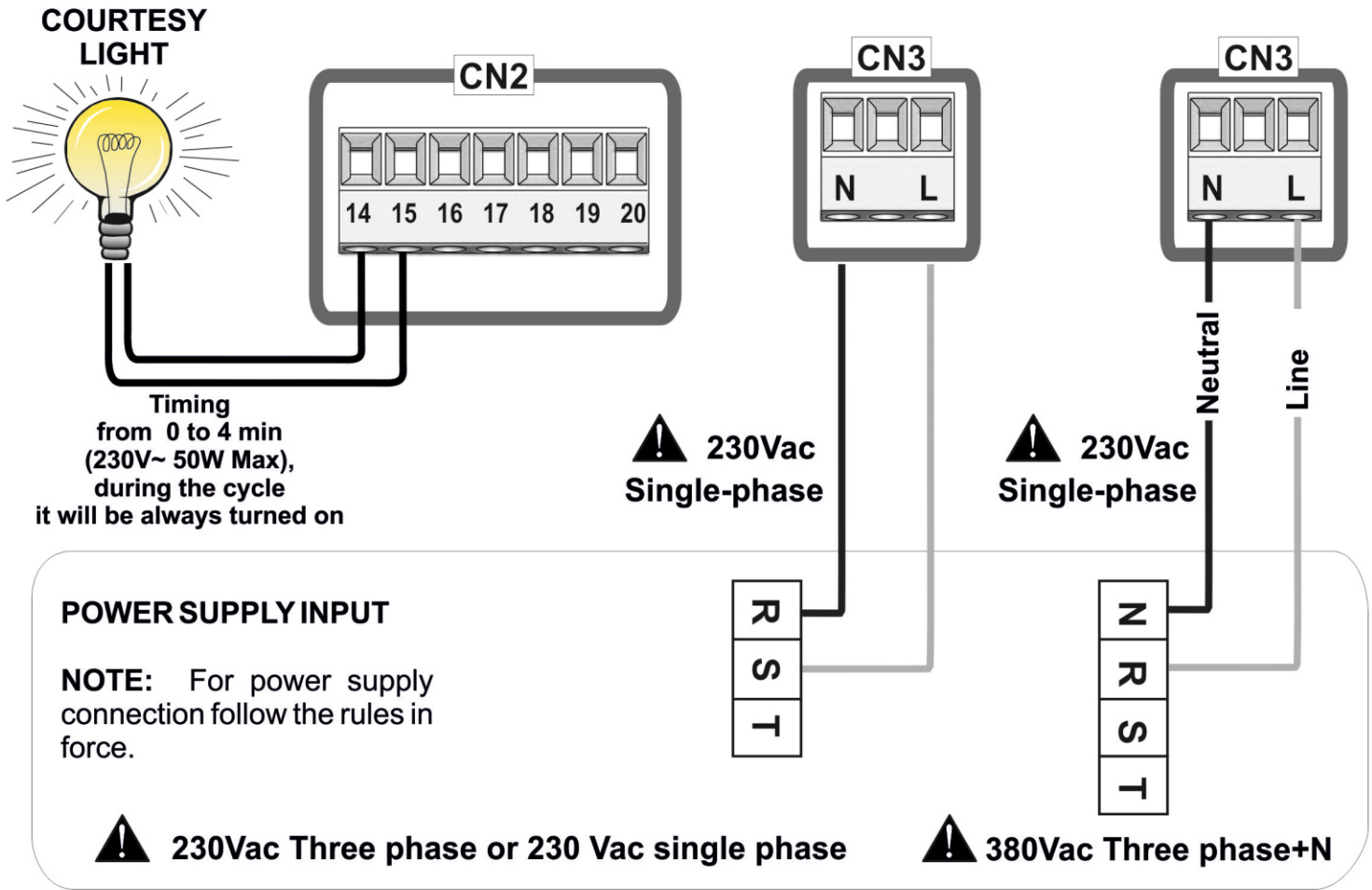

TRAFFIC LIGHT CARD CONNECTION

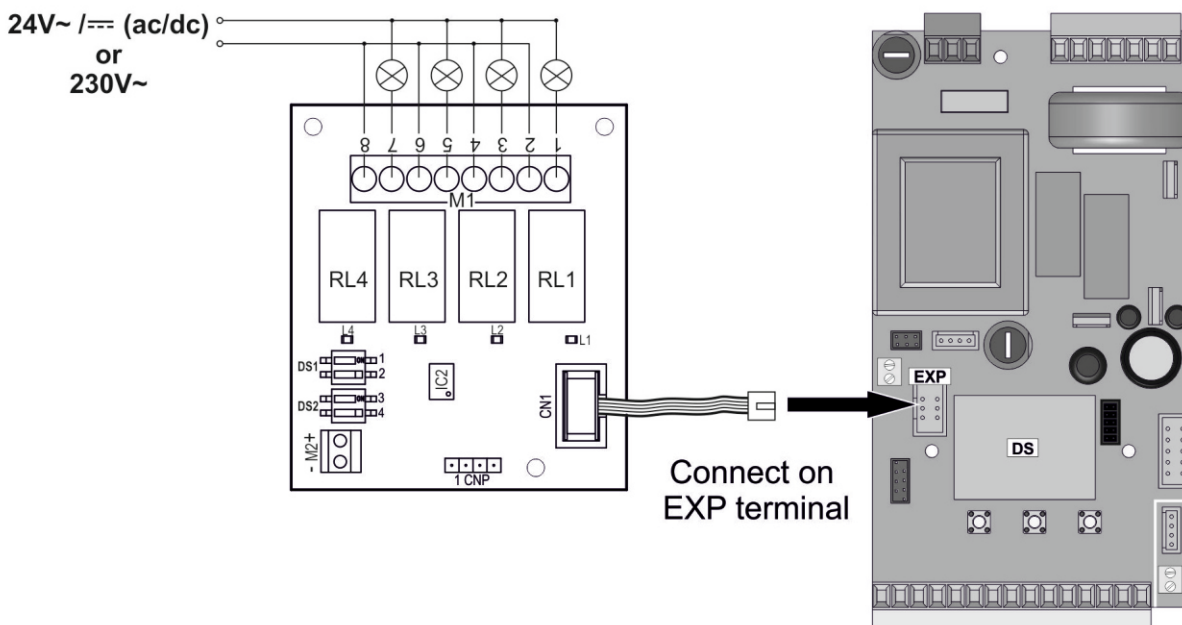

FOUR LIMIT SWITCH WITH LSE CARD

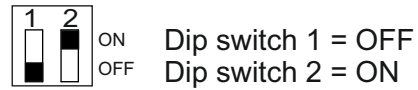
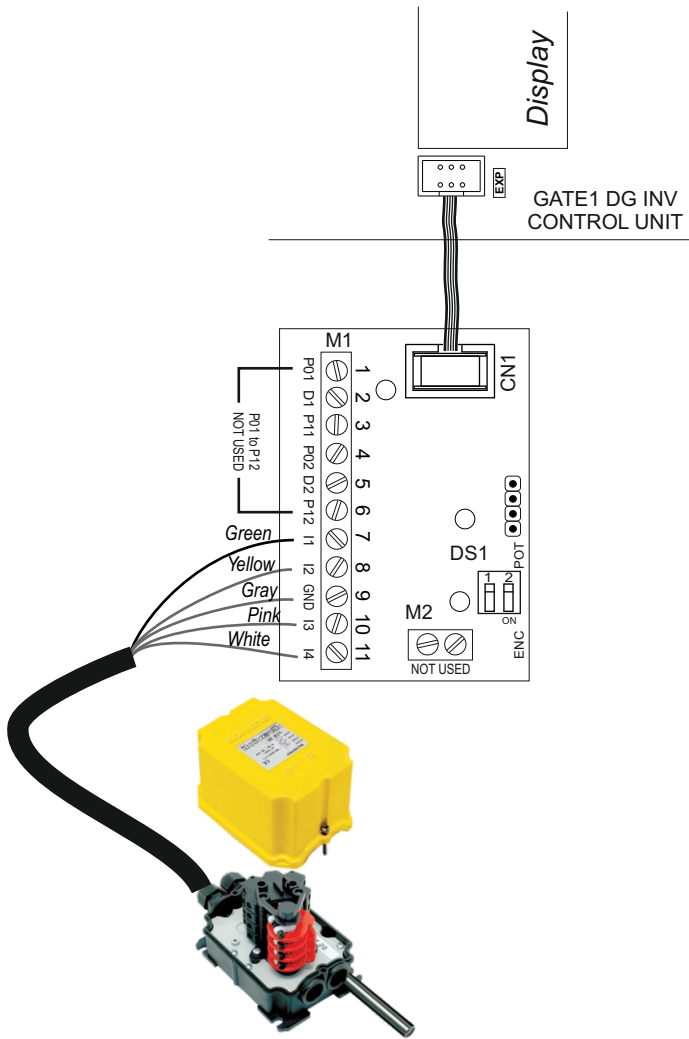

On the GATE1 DG INV to activate the EXT mode on Limit Switch Menu.

- I1 = Closing limit switch (green cable)
- I2 = Opening limit switch (yellow cable)
- GND = Common electronic control unit (grey cable)
- I3 = Slowdown closing limit switch (pink cable)
- I4 = Slowdown opening limit switch (white cable)

Note: The motor is already synchronized with the limit switches. If you invert the motor, you have to also invert the limit switches.

POTENTIOMETER MANAGEMENT (Position Gate)

(Available from revision 013 only on prepared motors)

The position gate ensures the correct position of the gate and the inversion on the obstacle, helping the installer to pass the certification of the automation.

To connect the potentiometer you must use the LE card (Cod.23001256) and set with Dip Switches 1 and 2 both in OFF.

With the potentiometer it is possible to access the hidden DEBUG menu to check the maximum settable value as threshold in normal and slowdown speed.

To access this menu you have to press, in the menu that displays the firmware version, UP and OK at the same time until the menus VP1 speed of potentiometer 1 will appear.

To view the speed of the potentiometer on the related menu, press OK.

To exit the DEBUG menu go to END and press OK.

If the reading of the potentiometer is reversed relative to the movement of the motor, on the display will appear the alarm "Potentiometer direction" and you will have to reverse the brown wire with the green one and repeat programming..

For a quick inversion on the obstacle you have to lower the sensitivity parameters.

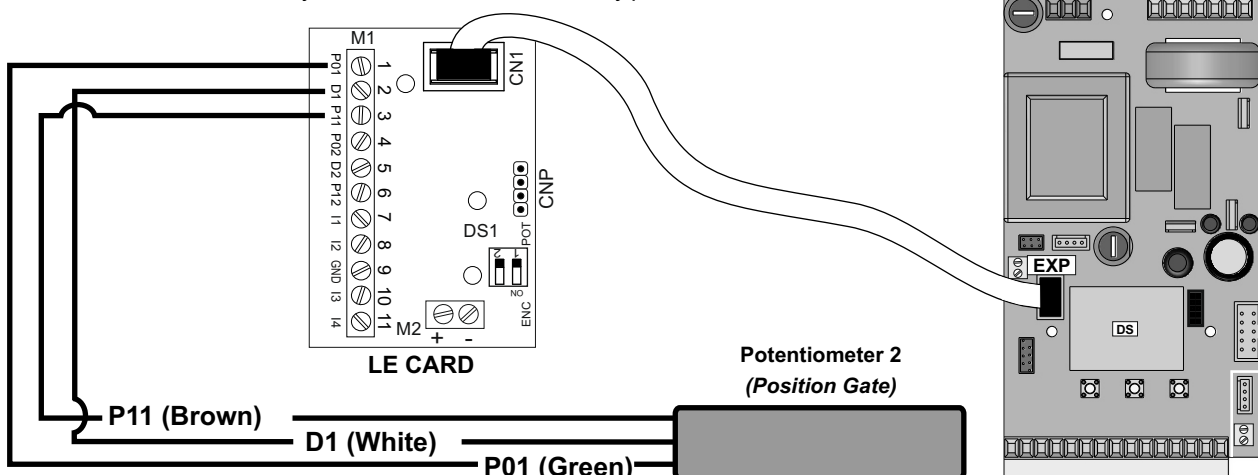

INVERTER MODULE CONNECTION
(Already wired)

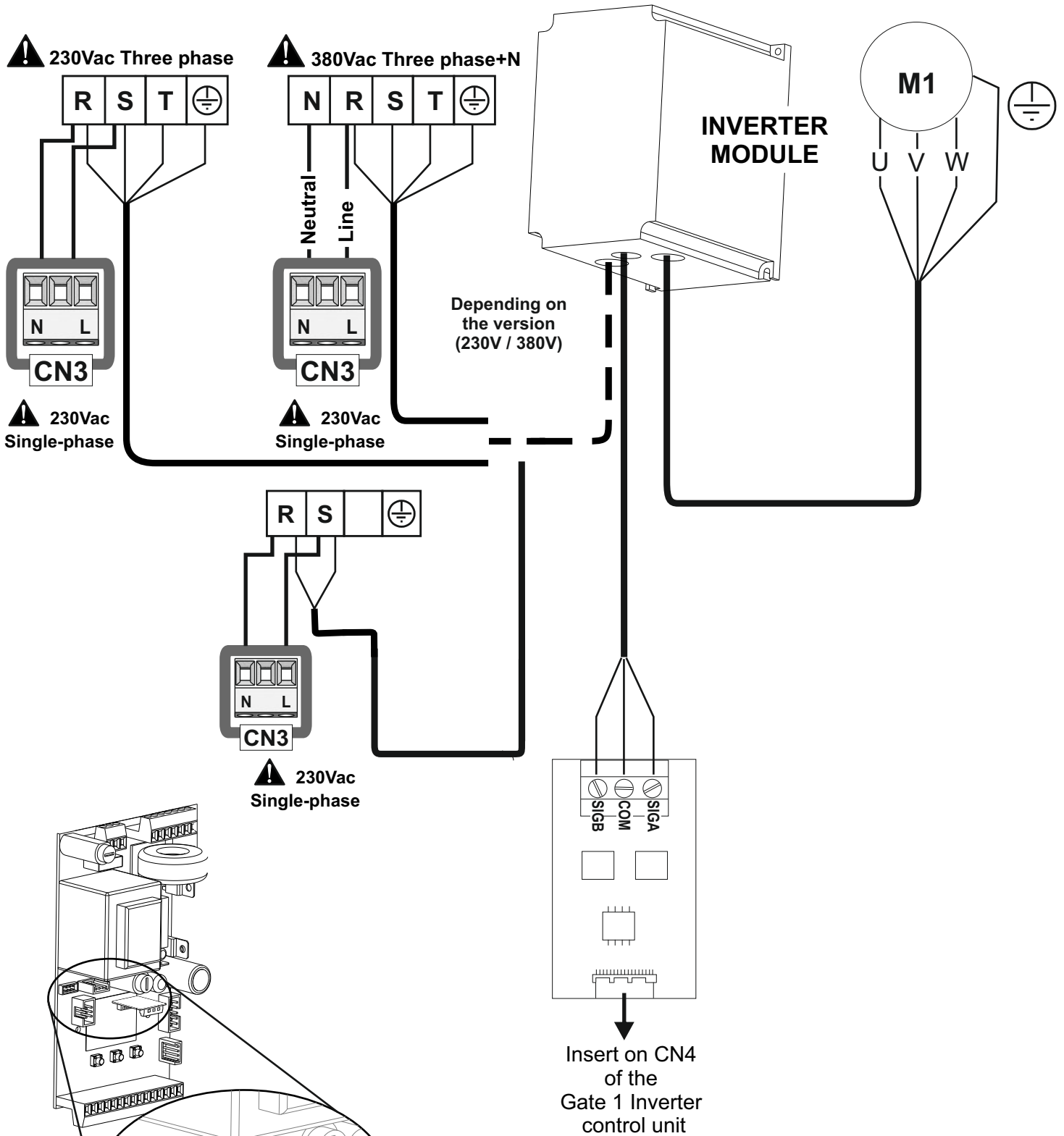

**(CMS) INVERTER
INTERFACE CONNECTOR**

ALARM DESCRIPTION

Signals	Kind of alarm	Solutions
FAILURE INVERTER	Inverter failure	Check the connections between Gate 1 DG and inverter module.
FAILURE24	24V Power supply failure	Make sure there are no short circuits on the wiring or on the control unit and no overloads.
FAILURE24VAUX	AUX output voltage	Make sure there are no short circuits on wiring or control unit and no overload.
FAILURE NET	Power supply failure	Check the network or the F2 fuse
FAILURE SELF TEST	Self-test photocells failure	Check the photocells operation and / or connections on the control unit.
FAILURE LIMIT SWITCH	Limit switch activation failure	Check the operation of both limit switches and / or correspondence between movement direction of the motor and engaged limit switches.
FAILURE FLASHING LIGHT	Flashing lamp failure	Check connections and / or conditions of the lamp.
FAILURE POTENTIOMETER	Potentiometer failure	The message appears only if the potentiometer is ON and the potentiometer (LE) card is broken or not connected.

Note 1: If in the diagnostics shows "Max. cycles reached", do the maintenance and / or reset the number of cycles performed.

Note2: To exit from the error messages, press OK. If the error persists, make all required checks for the specific error and / or disconnect the device that generates the error to see if the error disappears.

At each opening and closing of the automation the flashing light will blink. It blinks once per second during opening and twice per second during closing, while it remains lit during pause.

It is possible to view the alarms also on the flashing light or on the control lamp, simply by observing the number of flashes emitted and verifying the reference in the table below:

Blinks	Cause of alarm
9	Inverter failure
2	Photocell in closing
3	Photocell in opening
4	Safety edge

Blinks	Cause of alarm
5	Stop
7	Max. Cycles reached
6	Collision in opening/closing
4 fast	Limit switch fault

TROUBLE SHOOTING

Advices		
Make sure all Safeties are turned ON		
Problem Found	Possibile Cause	Solutions
Motor doesn't respond to any START impulse	a.) Check the connected N.C. Contacts b.) Burnt fuse	a.) Check the connections or the jumpers on the connections of the safety edge or of the stop and of the photocell if connected b.) Replace the burned fuse on the control unit
Gate doesn't move while the motor is running	a.) The motor is in the released position b.) There is an obstacle	a.) Re-lock the motor b.) Remove obstacle
Gate doesn't reach the complete Open / Closed position	a.) Wrong setting of the limit switches b.) Error on programming c.) Gate is stopped by an obstacle d.) Amperometric threshold too low	a.) Set limit switches b.) Repeat programming c.) Remove obstacle d.) Increase the current threshold parameter
The gate opens but doesn't close	a.) The contacts of the photocells are connected and open b.) The stop contact is connected and open c.) The edge contact is open	a.) b.) c.) Check the jumpers or the connected devices and the signals indicated on the warning lamp
The gate doesn't close automatically	a.) Pause time set to high b.) Control unit in semi-autom. logic	a.) Adjust pause time b.) Set the pause parameter on a different value from the OFF

Page for both instaler and user

MAINTENANCE

Considering the number of working cycles and the kind of gate, if the gate has changed the clutches and doesn't work it's necessary to periodically proceed, with **the learning times reprogramming on the electronic control unit**.
 Periodically clean the optical systems of the photocells.

REPLACEMENTS

Any request for spare parts must be sent to:
SEA S.p.A. - Zona Ind.le, 64020 S.ATTO - Teramo - Italia

SAFETY AND ENVIRONMENTAL COMPATIBILITY

Disposal of the packaging materials of products and/or circuits should take place in an approved disposal facility.



REGULAR PRODUCT DISPOSAL (electric and electronic waste)
 (It's applicable in EU countries and in those ones provided with a differential waste collection)

The brand that you find on the product or on documentation signals that the product must not be disposed off together with other domestic waste at the end of life cycle. In order to avoid any possible environmental or health damage caused by irregular waste disposal, we recommend to separate this product from other forms of waste and to recycle it in a responsible way in order to provide the sustainable re-use of material resources. Domestic users are invited to contact the retailer where the product has been purchased or the local office in charge of all the information related to differential waste collection and recycling of this kind of product.

STORING

WAREHOUSING TEMPERATURES			
T_{min}	T_{Max}	Dampness_{min}	Dampness_{Max}
- 20°C	+ 65°C	5% <i>Not condensing</i>	90% <i>Not condensing</i>

Materials handling must be made with appropriate vehicles..

WARRANTY LIMITS

For the guarantee see the sales conditions on the official SEA price list.

SEA reserves the right to make any required modification or change to the products and/or to this manual without any advanced notice obligation.

TERMS OF SALES

EFFICACY OF THE FOLLOWING TERMS OF SALE: the following general terms of sale shall be applied to all orders sent to SEA S.p.A. All sales made by SEA to all costumers are made under the prescription of this terms of sales which are integral part of sale contract and cancel and substitute all apposed clauses or specific negotiations present in order document received from the buyer.

GENERAL NOTICE The systems must be assembled exclusively with SEA components, unless specific agreements apply. Non-compliance with the applicable safety standards (European Standards EM12453 – EM 12445) and with good installation practice releases SEA from any responsibilities. SEA shall not be held responsible for any failure to execute a correct and safe installation under the above mentioned standards.

1) PROPOSED ORDER The proposed order shall be accepted only prior SEA approval of it. By signing the proposed order, the Buyer shall be bound to enter a purchase agreement, according to the specifications stated in the proposed order.

On the other hand, failure to notify the Buyer of said approval must not be construed as automatic acceptance on the part of SEA.

2) PERIOD OF THE OFFER The offer proposed by SEA or by its branch sales department shall be valid for 30 solar days, unless otherwise notified.

3) PRICING The prices in the proposed order are quoted from the Price List which is valid on the date the order was issued. The discounts granted by the branch sales department of SEA shall apply only prior to acceptance on the part of SEA. The prices are for merchandise delivered ex-works from the SEA establishment in Teramo, not including VAT and special packaging. SEA reserves the right to change at any time this price list, providing timely notice to the sales network. The special sales conditions with extra discount on quantity basis (Qx, Qx1, Qx2, Qx3 formula) is reserved to official distributors under SEA management written agreement.

4) PAYMENTS The accepted forms of payment are each time notified or approved by SEA. The interest rate on delay in payment shall be 1.5% every month but anyway shall not be higher than the max. interest rate legally permitted.

5) DELIVERY Delivery shall take place, approximately and not peremptorily, within 30 working days from the date of receipt of the order, unless otherwise notified. Transport of the goods sold shall be at Buyer's cost and risk. SEA shall not bear the costs of delivery giving the goods to the carrier, as chosen either by SEA or by the Buyer. Any loss and/or damage of the goods during transport, are at Buyer's cost.

6) COMPLAINTS Any complaints and/or claims shall be sent to SEA within 8 solar days from receipt of the goods, proved by adequate supporting documents as to their truthfulness.

7) SUPPLY The concerning order will be accepted by SEA without any engagement and subordinately to the possibility to get it's supplies of raw material which is necessary for the production; Eventual completely or partially unsuccessful executions cannot be reason for complains or reservations for damage. SEA supply is strictly limited to the goods of its manufacturing, not including assembly, installation and testing. SEA, therefore, disclaims any responsibility for damage deriving, also to third parties, from non-compliance of safety standards and good practice during installation and use of the purchased products.

8) WARRANTY The standard warranty period is 12 months. This warranty time can be extended by means of expedition of the warranty coupon as follows:

SILVER: The mechanical components of the operators belonging to this line are guaranteed for 24 months from the date of manufacturing written on the operator.

GOLD: The mechanical components of the operators belonging to this line are guaranteed for 36 months from the date of manufacturing written on the operator.

PLATINUM: The mechanical components of the operators belonging to this line are guaranteed for 36 months from the date of manufacturing written on the operator. The base warranty (36 months) will be extended for further 24 months (up to a total of 60 months) when it is acquired the certificate of warranty which will be filled in and sent to SEA S.p.A. The electronic devices and the systems of command are guaranteed for 24 months from the date of manufacturing. In case of defective product, SEA undertakes to replace free of charge or to repair the goods provided that they are returned to SEA repair centre. The definition of warranty status is by unquestionable assessment of SEA. The replaced parts shall remain propriety of SEA. Binding upon the parties, the material held in warranty by the Buyer, must be sent back to SEA repair centre with fees prepaid, and shall be dispatched by SEA with carriage forward. The warranty shall not cover any required labour activities.

The recognized defects, whatever their nature, shall not produce any responsibility and/or damage claim on the part of the Buyer against SEA. The guarantee is in no case recognized if changes are made to the goods, or in the case of improper use, or in the case of tampering or improper assembly, or if the label affixed by the manufacturer has been removed including the SEA registered trademark No. 804888. Furthermore, the warranty shall not apply if SEA products are partly or completely coupled with non-original mechanical and/or electronic components, and in particular, without a specific relevant authorization, and if the Buyer is not making regular payments. The warranty shall not cover damage caused by transport, expendable material, faults due to non-conformity with performance specifications of the products shown in the price list. No indemnification is granted during repairing and/or replacing of the goods in warranty. SEA disclaims any responsibility for damage to objects and persons deriving from non-compliance with safety standards, installation instructions or use of sold goods. The repair of products under warranty and out of warranty is subject to compliance with the procedures notified by SEA.

9) RESERVED DOMAIN A clause of reserved domain applies to the sold goods; SEA shall decide autonomously whether to make use of it or not, whereby the Buyer purchases propriety of the goods only after full payment of the latter.

10) COMPETENT COURT OF LAW In case of disputes arising from the application of the agreement, the competent court of law is the tribunal of Teramo. SEA reserves the faculty to make technical changes to improve its own products, which are not in this price list at any moment and without notice. SEA declines any responsibility due to possible mistakes contained inside the present price list caused by printing and/or copying. The present price list cancels and substitutes the previous ones. The Buyer, according to the law No. 196/2003 (privacy code) consents to put his personal data, deriving from the present contract, in SEA archives and electronic files, and he also gives his consent to their treatment for commercial and administrative purposes.

Industrial ownership rights: once the Buyer has recognized that SEA has the exclusive legal ownership of the registered SEA brand num.804888 affixed on product labels and / or on manuals and / or on any other documentation, he will commit himself to use it in a way which does not reduce the value of these rights, he won't also remove, replace or modify brands or any other particularity from the products. Any kind of replication or use of SEA brand is forbidden as well as of any particularity on the products, unless preventive and expressed authorization by SEA.

In accomplishment with art. 1341 of the Italian Civil Law it will be approved expressly clauses under numbers:

4) PAYMENTS - 8) GUARANTEE - 10) COMPETENT COURT OF LOW



GENERAL NOTICE FOR THE INSTALLER AND THE USER

1. Read carefully these **Instructions** before beginning to install the product. Store these instructions for future reference
2. Don't waste product packaging materials and /or circuits.
3. This product was designed and built strictly for the use indicated in this documentation. Any other use, not expressly indicated here, could compromise the good condition/operation of the product and/or be a source of danger. SEA S.p.A. declines all liability caused by improper use or different use in respect to the intended one.
4. The mechanical parts must be comply with Directives: Machine Regulation 2006/42/CE and following adjustments), Low Tension (2006/95/CE), electromagnetic Consistency (2004/108/CE) Installation must be done respecting Directives: EN12453 and En12445.
5. Do not install the equipment in an explosive atmosphere.
6. SEA S.p.A. is not responsible for failure to observe Good Techniques in the construction of the locking elements to motorize, or for any deformation that may occur during use.
7. Before attempting any job on the system, cut out electrical power and disconnect the batteries. Be sure that the earthing system is perfectly constructed, and connect it metal parts of the lock.
8. Use of the indicator-light is recommended for every system, as well as a warning sign well-fixed to the frame structure.
9. SEA S.p.A. declines all liability as concerns the automated system's security and efficiency, if components used, are not produced by SEAS.p.A..
10. For maintenance, strictly use original parts by SEA.
11. Do not modify in any way the components of the automated system.
12. The installer shall supply all information concerning system's manual functioning in case of emergency, and shall hand over to the user the warnings handbook supplied with the product.
13. Do not allow children or adults to stay near the product while it is operating. The application cannot be used by children, by people with reduced physical, mental or sensorial capacity, or by people without experience or necessary training. Keep remote controls or other pulse generators away from children, to prevent involuntary activation of the system.
14. Transit through the leaves is allowed only when the gate is fully open.
15. The User must not attempt to repair or to take direct action on the system and must solely contact qualified SEA personnel or SEA service centers. User can apply only the manual function of emergency.
16. The power cables maximum length between the central engine and motors should not be greater than 10 m. Use cables with 2,5 mm² section. Use double insulation cable (cable sheath) to the immediate vicinity of the terminals, in particular for the 230V cable. Keep an adequate distance (at least 2.5 mm in air), between the conductors in low voltage (230V) and the conductors in low voltage safety (SELV) or use an appropriate sheath that provides extra insulation having a thickness of 1 mm.



Questo articolo è stato prodotto seguendo rigide procedure di lavorazione ed è stato testato singolarmente al fine di garantire i più alti livelli qualitativi e la vostra soddisfazione. Vi ringraziamo per aver scelto SEA.

This item has been produced following strict production procedures and has been singularly tested for the highest quality levels and for your complete satisfaction. Thanks for choosing SEA.

Cet article a été produit suivant des procédures d'usinage strictes et il a singulièrement été testé afin de garantir les plus hauts niveaux de qualité pour votre satisfaction. Nous vous remercions d'avoir choisi SEA.

Este artículo ha sido producido siguiendo rigidos procedimientos de elaboracion y ha sido probando singolarmente a fin de garantizar los mas altos niveles de calidad y vuestra satisfaccion. Le agradecemos por haber escogito SEA.



SEA[®]

Sistemi Elettronici
di Apertura Porte e Cancelli
International registered trademark n. 804888



SEA S.p.A.
Zona industriale 64020 S.ATTO Teramo - (ITALY)
Tel. +39 0861 588341 r.a. Fax +39 0861 588344

www.seateam.com

seacom@seateam.com