



Installation Instructions
for the garage door operators

TS 75

TS 100



English

Content

Information and Remarks

Directives and Regulations
Use of the operators
Garage Doors
The installers declaration of conformity
Older Garage Doors

Important Information for the Installer 3

Instruction for the users

Security Advises for the Installation 4

Installation

Different Conditions for Installation 5

Minimum space above the garage door
Door Arm Extension
C-Rail Extension
Bow Arm Conversion

Pre-Mounting the operator 6

Installing the operator 7

The Emergency Release 8

When there is a second entrance to the garage
When the garage door is the only entrance

Printed Circuit Board: Adjustments and Connections

Devices for Adjustments 9

TEST/RUN-Button (1)
LERN/LEARN-Button (2)
Potentiometer "PRESSURE OPEN/CLOSE" (3)
Potentiometer "LIGHT" (4)

Limit-Switch Adjustment and Force Measurement 10

Information
1.) Adjusting the maximum force for the learning-cycle
2.) Starting the learning-mode
3.) The Limit Switch Adjustment
4.) Starting the learning cycle
Quick Reference

The most important connectors 12

Push Button and Key Switch
24V DC Supply
230V AC Supply
Receiver-Module

Advanced Connectors 12

Photo-Cell without selftest:
Photo-Cell with selftest
Security Beam and Hatch Door
Modules for Special Functions
Cycle Counter

LED-Lamps 14

LED "TEST"
LED "Diag"
LED "Vp"
LED "SLZ"
LED "LSZ"
LED "SEZ"
LED "SEA"

Special Functions 15

DIP-Switch Settings
Automatic Force Measurement
Additional Force
Pre-Warning light before every movement
Full reversion in OPENING direction
No reversion on Security-Beam when door closed
Side Hinged Doors

Remote Control

Programming the Hand Transmitters 16

Basics
Programming Transmitter and Receiver
Clearing the receivers' memory

Additional Information 17

Criteria influencing the range
Use with a HomeLink© System

Technical Information

Technical Data 18

Optional Special Functions 18

Module "Automatic Closing" (AZ)
Module "Separated Impulse" (TO)
Module "One Way Traffic Control" (EI)

Wiring 19

Internal Wiring
External connections

Spare Parts 20

Troubleshooting

Troubleshooting 21

Error Messages
Error messages via the operator's light
If... then...
Additional messages only via the LED "Diag"

Declaration of Conformity

Important Information for the Installer

It is within legal regulation and without restriction, to use a Seip door operator with any garage door that has been approved for use with other certified door operators!

Directives and Regulations

The operators TS 75 and TS 100 comply to the latest European directives and regulations. The declaration of conformity is enclosed at the end of these instructions.

Use of the operators

The operators were designed for the use with up-and-over doors (tilting and canopy-type) and sectional doors. They can be used with side-hinged doors using a special conversion-kit.

All garage doors need to be maintained before automation. The door must be easily opened and closed by hand. A garage door must not be automated unless it is easy to open and close manually.

Garage Doors

In January 2001 the European regulations EN12604 and EN12605 became compulsory for garage doors. Before installing an automatic door operator it must be assured that the garage doors applies to these regulations (the information can be obtained from the manufacturers' declaration of conformity). A Seip door operator may be installed to any door that complies to the regulations. Should a garage door not be compliant then please refer to the chapter „older garage doors“.

The installers declaration of conformity

No matter whether a door operator was delivered together with a garage door or separately, the installer must issue a declaration of conformity for the complete installation.

With this declaration the installer assures, that the installation was made according to the instructions given by the manufacturers (e.g. the installation instructions of the garage door and the operator). This declaration can only be issued by the installer and may not be issued from the manufacturer!

If both components comply to the directives and the installation was made as to the manufacturers instructions the whole installation will normally be CE-compliant.

Older Garage Doors

When automating an older garage-door the TS-series will still comply to the regulations - through the automatic force setting the requested values for forces and reversion will be according to the regulations.

But it needs to be taken in consideration that most older garage doors do not meet the regulations EN 12604 and EN 12605 - especially regarding security features. They might still have sharp edges bearing the danger of severe injuries - for example sectional doors might not have a finger protection between the sections. Unfortunately the entire regulations do not mention how to handle the automation of such an older garage door - the danger basically is not the automation but the construction of the door.

Therefore we strongly recommend to

- check the garage door for sharp edges bearing danger when the door is moving; take any necessary action to avoid the dangers and make the door safer
- check the doors' springs and readjust them if necessary
- grease or oil the pivotal points and rollers of the garage door
- check that the door may be easily used by hand



If, however, the dangers cannot be avoided we recommend to use the automatic pre-warning function of the operator. The operators' lighting will then be blinking for approx. 5 sec. before every movement of the garage door. People inside the garage will be warned before the opening and can step back from the garage door in time.

Instruction for the users

Please instruct the users as follows:

- Use of the hand transmitter
- Use of the emergency release in case of a power failure
- Hand over the separate „User Manual“ to the customer
- Inform the user about the Security Advises in the User Manual

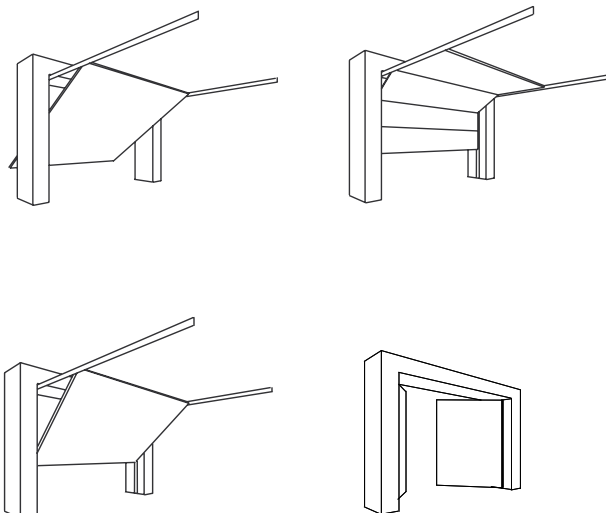

Security Advises for the Installation

Important Safety Instructions for Installation

WARNING: INCORRECT INSTALLATION CAN LEAD TO SEVERE INJURY

Follow all Installation Instructions.

- Read page 3 of this instruction carefully before the installation
- Before installing the drive, remove unnecessary ropes from the existing installation
- Maintain the garage door according to the advises on page 3 and to the door manufacturer's manual
- If possible, install the drive at a height of at least 2,10 m and the manual release at a height less than 1,80 m
- Locate the push-button within sight of the door but away from moving parts and at a minimum height of 1,50 m
- Fix the label warning against entrapment next to the push-button
- The label fixed to the manual release may not be removed
- After installation, ensure that the mechanism is properly adjusted and that the drive reverses when the door contacts a 40 mm high object placed on the floor.

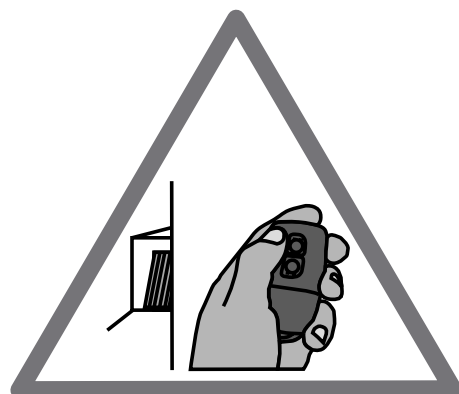
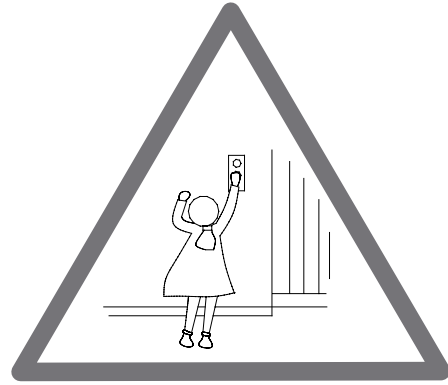

Different Conditions for Installation

Minimum space above the garage door

35mm Minimum

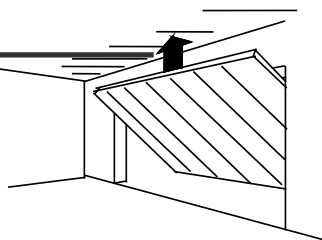

Before installing the operator you should check the garage for the conditions of installation. You will need optional extras in either of the following situations:

C-Rail Extension

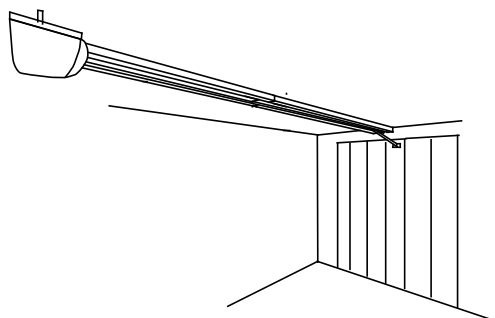

If the garage door is higher than 2.250 mm you will need a c-rail extension. Two sizes of extensions are available: 500mm and 1.000 mm.

The operator may be extended by a maximum of 1.500mm - the maximum height of a garage door is 4.150mm.

Bow Arm Conversion

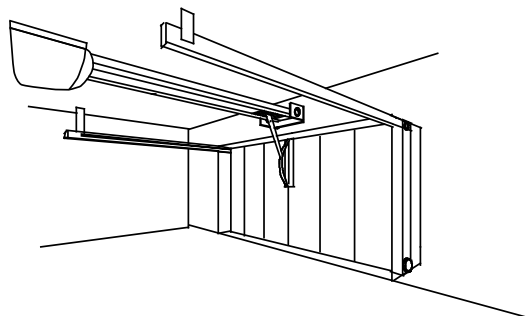

For a canopy type garage door (inside turning door) you will need a bow arm conversion to automate the door.

Inside turning doors are equipped with a roller on each side at the bottom of the door. With these rollers the door cannot tilt outside - an automation without the bow arm conversion is not possible.

Door Arm Extension

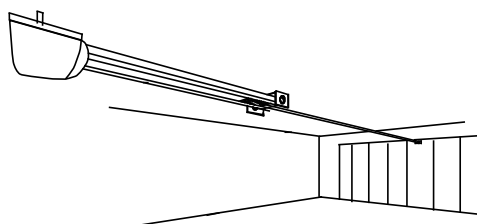

Should the minimum space between the garage door and the ceiling be smaller than 35mm then a door arm extension is needed.

For an extension you can use a metal beam from any DIY-market. The beam should not be shorter than the door's height.

Pre-Mounting the operator

During this procedure be careful not to twist the chain. **Therefore do not lift the parts - slide them along the floor.**

1. The operator is laying unpacked in front of you. The motor-head unit is on your right hand side.
2. Lay part (1) to the front.
3. Fix through pushing the C-profile coupling piece (2) over it all the way home.
4. Slide C-rail part (3) in front of part (1)
5. Set part (3) in the C-rail coupling piece (4) at an angle, inserting it from above as shown.
6. Press down part (3) to tension the chain.
7. Turn around the operator and screw in the milled nuts into the C-rail coupling pieces.

Your operator now is readily premounted for installation.

The chain has been pretensioned in the factory; **do not change the chain tension!**

ATTENTION:

The setting of the limit-switches and the automatic-force adjustment were set for factory testings. When you change the limit-switch settings you first have to run a new learning cycle to make the operator work properly! (Please refer to the pages 10+11)

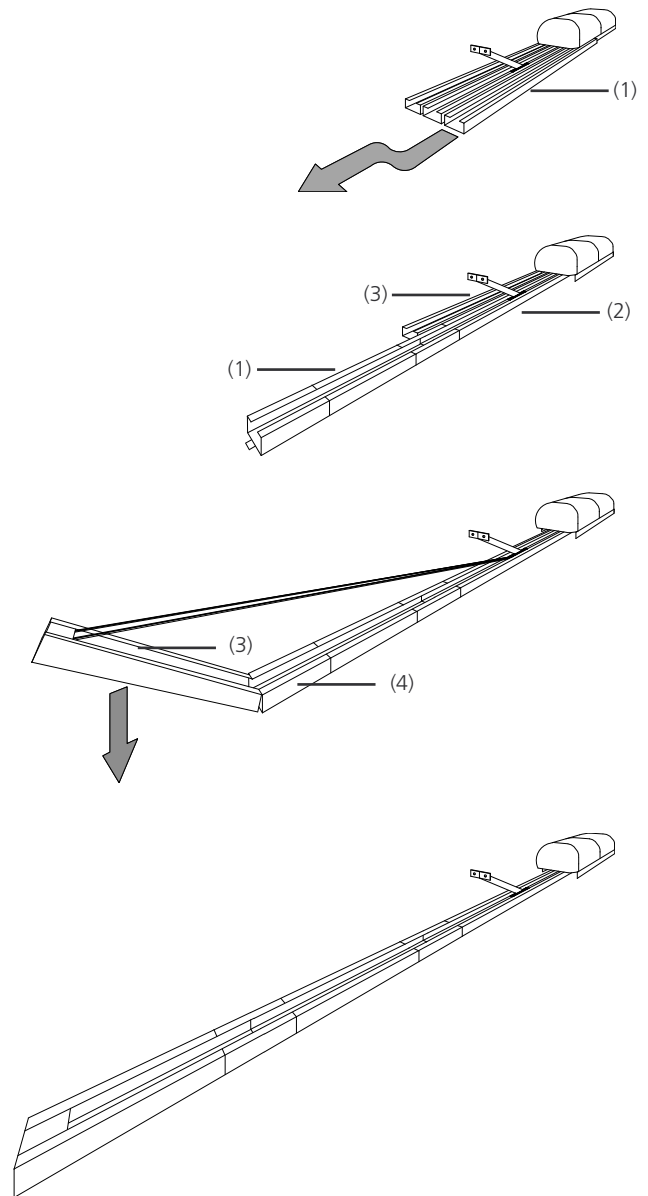

Installing the operator

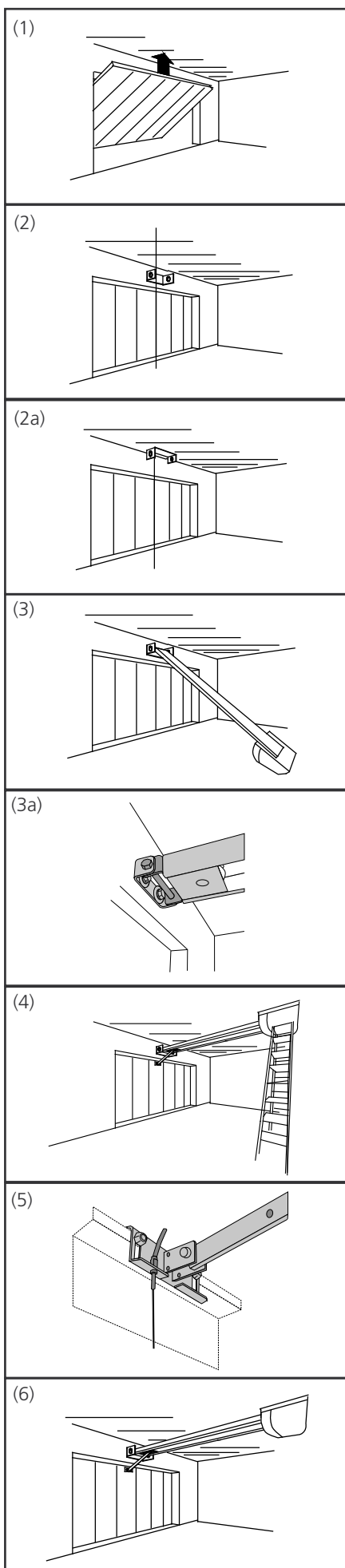

Measure the distance between the ceiling and the highest point reached by the garage door (1).
The minimum-headroom necessary for mounting the operator is 35 mm. If there is less headroom please pay attention to page 5.

The front fixing angle can be mounted either at the lintel or at the ceiling.

1. Measure the middle of your garage door and make a mark on the lintel and the top of your door (2+2a).

2. Fix the front fixing angle in the middle either at the lintel or at the ceiling. (We recommend the lintel if possible) (2+2a).

3. Attach the C-rail to the front fixing angle (3). Put a carton piece under the motor head unit to avoid damages.

4. To fix the motor head to the ceiling we recommend you to use a ladder (4). When the operator is laying on the ladder you can open the garage-door. Adjust the C-rail according to the mark you made in the middle of the garage-door.
Fix the operator to the ceiling when you have made sure the C-rail is running straight to the front.

5. Now fix the door arm to the garage door (5). Take care that the angle between the operator and the door arm does not exceed a max. of 45° (it may be lower).

6. Before running the operator disengage the door's locking-bolts otherwise the operator cannot open the door. This could result in damage to the operator and/or the garage door. The self-locking gear of the operator will ensure that the door cannot be opened manually. If you require additional security, ie using door bolts, please ask your dealer for our locking set, which is available as an optional extra.

The Emergency Release

In case of a power failure the garage door can be opened by hand. Therefore the operator first needs to be released.

When the garage door is the only entrance

It is necessary to connect the emergency release to the door's handle (pic. 1) otherwise the garage cannot be accessed in a power failure situation.

Proceed as follows:

1. Find out in which direction the door handle moves when opening the door.
2. Drill a hole in that side of the door handle which turns downwards.
3. Thread the cable through the hole and fix it with the enclosed metal-clamps. Be careful not to put a high tension on the emergency release cable - the operator then might release from the garage-door during a normal opening cycle.
4. Check the function of the emergency release together with a second person. Stay inside the garage and close the door with the operator. Let the second person open the door manually with the door keys. If this works, the emergency-release is mounted properly.

Do not leave the garage and close the garage-door with the operator before you have tested the emergency-release!

When there is a second entrance to the garage

You can use the supplied handle for the emergency release (pic. 2).

Thread the emergency release cable through the handle.

Fix the metal clamps to the cable where the handle shall be placed.

Shorten the cable below the metal clamps - the handle is now being held by the clamps.

In case of a power failure the user can now open the garage door by releasing the operator with the handle for the emergency release.

Pic. 1

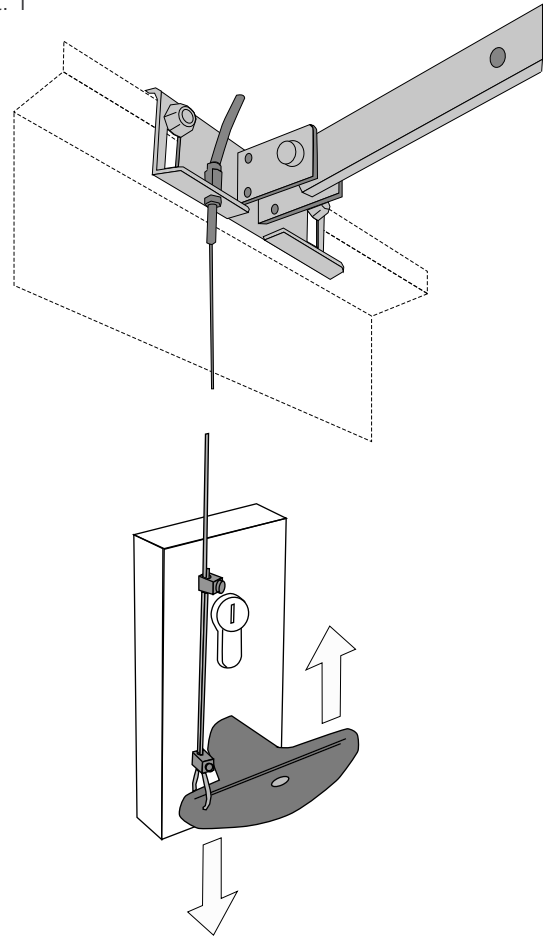

Pic. 2

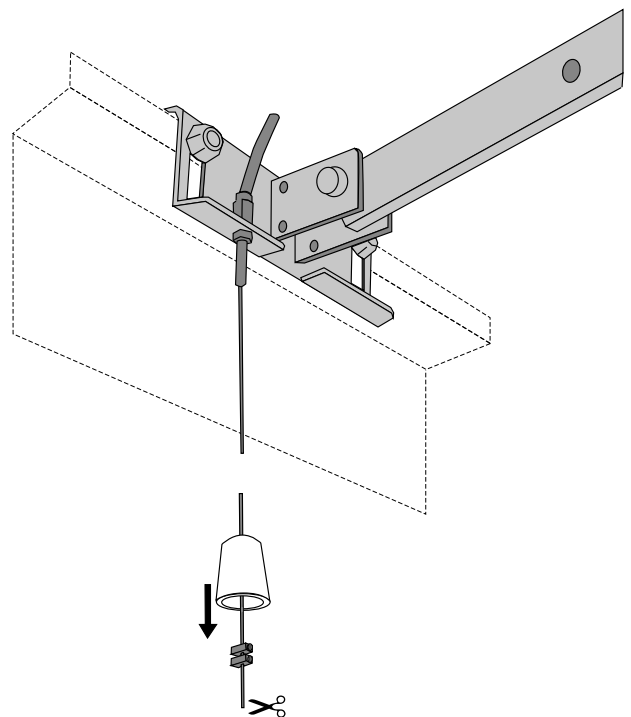

Devices for Adjustments

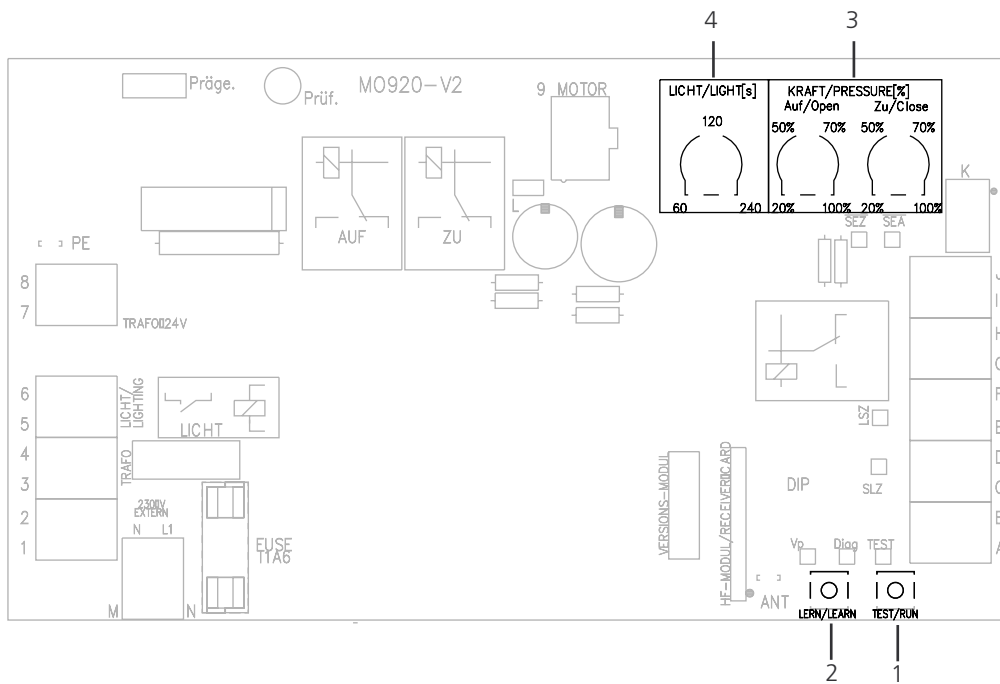

This page only shows the functions of the buttons and potentiometers on the P.C.B.. To programme the operator please refer to page 10 onwards.

TEST/RUN-Button (1)

With this button you put the operator into operation. The button works on the OPEN-STOP-CLOSE principle, e.g. the first push opens the door, the second push stops the door and the third push closes the door etc. The LED-lamp "TEST" is switched on as long as you press the TEST-button and shows that the impulse was received and recognised by the electronics.

LERN/LEARN-Button (2)

This button has two functions:

1. Learning the forces
2. Registering (learning) a hand-transmitter

The LERN/LEARN-button must be pressed for approx. 3 sec.; the button can be released once the operator's light starts blinking. Whilst the operator's light is blinking you can either register a new hand-transmitter by pushing the hand transmitters button OR you may start the learning of forces by pressing the button once again.

Details on both procedures can be obtained from the chapters "Automatic Force Setting" and "Remote Control".

Potentiometer "PRESSURE OPEN/CLOSE" (3)

With these potentiometers you must adjust the maximum force for the force learning cycle (please refer to the chapter "Automatic Force Setting") separately for OPENING and CLOSING direction. The operator will never override the adjusted forces, neither during the learning cycle nor in later use! The maximum forces are shown in %. Depending on the operator model this means:

max.force %age	Operator with 75 kg max.	Operator with 100 kg max.
20%	15 kg approx.	20 kg approx.
50%	37 kg approx.	50 kg approx.
70%	52 kg approx.	70 kg approx.
100%	75 kg	100 kg

Potentiometer "LIGHT" (4)

With this potentiometer the time for the internal lighting is adjusted in seconds. Values from 80 to 240 seconds are adjustable.

Limit-Switch Adjustment and Force Measurement

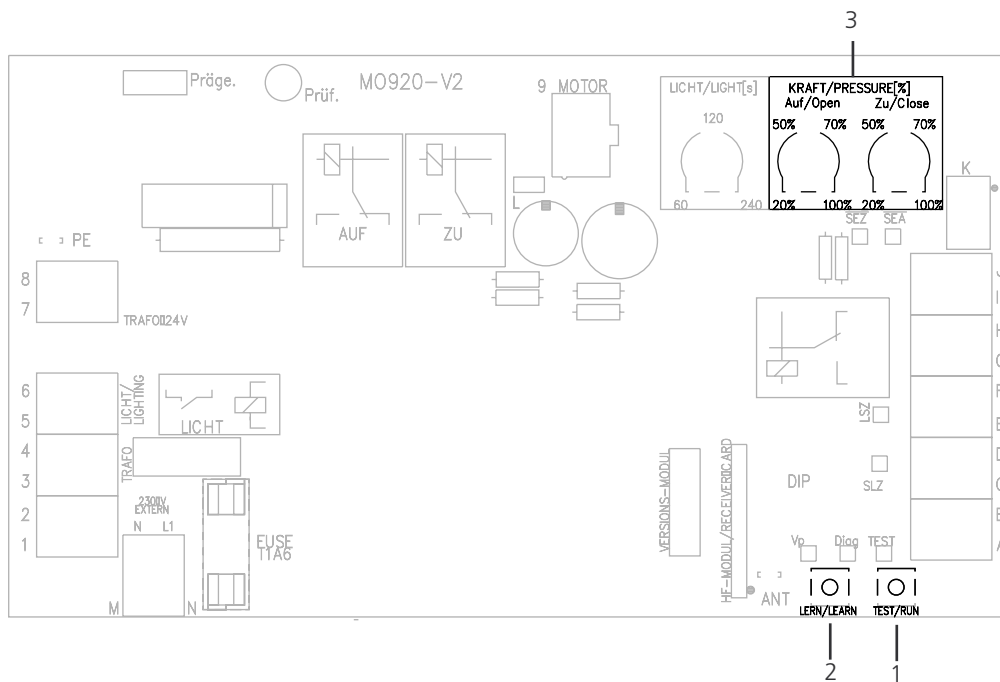

Pictures:

- 1: TEST/RUN-Button
- 2: LERN/LEARN-Button
- 3: Potentiometer for Force Adjustment

Information

To use the operator the following steps must be carried out to adjust the limit-switches and to learn the required force. **Without these adjustments the operator will only run for the factory set distance when pressing the TEST-button.**

The limit-switch adjustment and the force-learning are both done in one combined programming step. The operator needs to be set into programming-mode - the programming-mode is indicated by the blinking operator's light. During the programming-mode the limit-switch setting is done first, followed by the force-setting.

The procedure of adjustments:

- 1.) Adjustment of the maximum force for learning-mode
- 2.) Start of programming-mode
- 3.) OPENING limit-switch
 - b.) Adjustment CLOSING limit-switch
- 4.) Start the learning-cycle for force and distance.

Descriptions of each step will be found in the following text.

1.) Adjusting the maximum force for the learning-cycle

The force adjusted via the potentiometers "FORCE OPEN" and "FORCE CLOSE" determines the maximum forces for the learning cycle and in later use. The factory setting is 60% for both. On smaller, easy running doors a force of 40% will be sufficient.

2.) Starting the learning-mode

Press the LERN/LEARN button (2) on the main electronics for approx. 3 seconds. When the operator's light begins blinking - release the LERN/LEARN button.

The operator now runs in learning-mode. *The learning-mode runs without time-limit - there is no need to rush with the following adjustments.*

3.) The Limit Switch Adjustment

In CLOSING-position the garage door shall not be pressed hard onto the doors' frame. If it is pressed too hard then the operator will reverse after each CLOSING and the garage door will remain open for approx. 5 cm.

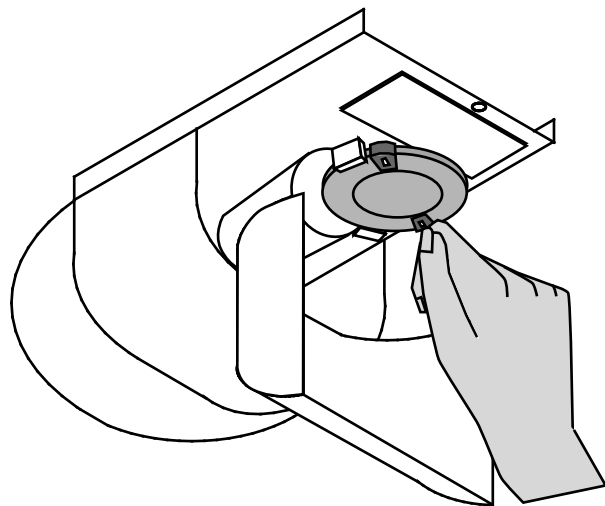
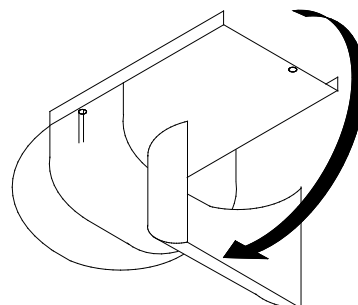
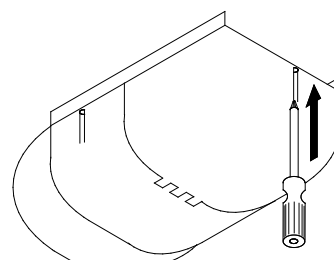

Limit-Switch Adjustment and Force Measurement

Basics: During the learning-mode the operator will follow the limit-switches automatically when these are moved.

E.g.: The operator hits the CLOSING limit-switch but the garage-door still is not completely closed. You can now slide the red limit-switch actuator off the CLOSING limit-switch - the operator will automatically start running in CLOSING direction until it hits the CLOSING limit-switch again. You do not have to press the TEST/RUN button to activate the operator.

The procedure works vice-verca in OPENING direction.

Attention: the operator only follows the limit-switch in ONE direction - the CLOSING limit-switch is only followed in CLOSING direction, the OPENING limit-switch is only followed in OPENING direction.

To run the operator in another direction you have to press the TEST/RUN button.

The operator's light will be blinking throughout the whole procedure of setting the limit switch.

3.)a.) Adjusting the OPENING limit switch

1.) Run the operator in OPENING direction using the TEST/RUN button (1) (the button follows the principle OPEN-STOP-CLOSE etc., e.g. first impulse OPEN, second impulse STOP, third impulse CLOSE etc.)

2.) When the garage door is almost opened to maximum you have to stop the operator using the TEST/RUN button. Then slide the OPENING limit switch actuator so that it hits the limit-switch.

3.) When the OPENING limit switch is hit before the garage door is opened to maximum then simply slide the red limit switch actuator further in OPENING direction - the operator will follow the movement.

3.)a.) Adjusting the CLOSING limit-switch

1.) Run the operator in CLOSING direction using the TEST/RUN button (1) (the button follows the principle OPEN-STOP-CLOSE etc., e.g. first impulse OPEN, second impulse STOP, third impulse CLOSE etc.)

2.) When the garage door is closed you have to stop the operator using the TEST/RUN button. Then slide the OPENING limit switch actuator so that it hits the limit switch.

3.) When the CLOSING limit switch is hit before the garage door is closed then simply slide the red limit switch actuator further in CLOSING direction - the operator will follow the movement.

4.) Starting the learning cycle

Press the LERN/LEARN button after the limit switches are adjusted properly (the garage-door should then be closed and the CLOSING limit-switch is actuated).

The operator then starts the automatic learning cycle and will do three runs:

- OPENING the garage door
- CLOSING the garage door
- OPENING the garage door.

All three runs are done fully automatic.

After the learning cycle the operator will rest in OPENING position - the operator's light stops blinking. **The operator now is ready for use.** For programming the hand-transmitter please refer to the chapter "Remote-Control" on page 16.

Quick Reference

1.) Force Adjustment

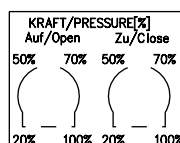

Adjust the maximum force for OPENING and CLOSING direction for the learning cycle

2.) Start programming mode



Press the LERN/LEARN button for approx. 3 seconds. The operator's light begins blinking - release the LERN/LEARN button

3.) Limit Switch Adjustment

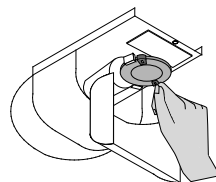

a.) Adjust OPENING limit switch
b.) Adjust CLOSING limit switch
(The operator can be run in OPENING and CLOSING direction using the TEST/RUN button)

4.) Start learning cycle



The garage door is closed and the operators hits the CLOSING limit switch
Press the LERN/LEARN button shortly
The operator does three runs (OPENING-CLOSING-OPENING)

The learning cycle stops after the three runs. The garage door is then opened and the operator's light stops blinking. The programming is now complete.

5.) You may now proceed with chapter "Remote Control" on page 16

The most important connectors

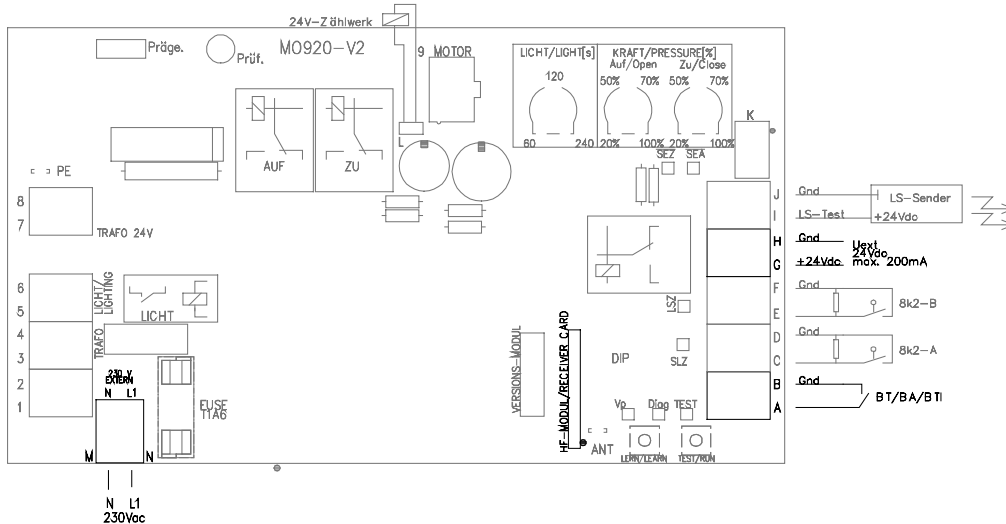

Component	Connector	Function
Push Button and Key Switch	A + B	Floating connector for push button and key switch: no electricity to come into contact with these connectors! When using an external receiver the impulse wires are connected to this terminal.
24V DC Supply	G + H	24V DC power supply for external components (external receiver, photo-cell), a maximum of 200 mA is allowed.
230V AC Supply	M + N	230V AC power supply for external components. Shortcuts created by external components on this connector will influence the house fuse directly.
Receiver-Module	HF-Modul / Receiver-Card	Plug for Seip remote-receiver cards.

Advanced Connectors

Component	
<p>Photo-Cell without selftest:</p> <p>C + D (with 8,2 kOhm resistor)</p>	<p>Wiring:</p>
<p>Photo-Cell with selftest</p> <p>C + D (Photo-Cell receiver)</p> <p>I + J (Photo-Cell transmitter)</p>	<p>The main electronics provides the possibility of testing the photo-cell before every movement - within milliseconds a malfunction of the photo-cell is simulated. To enable the main-electronics for this testing the impulse cables of the photo-cells' transmitter must be connected to I + J and the impulse cables of the photo-cell's receiver must be connected to C + D.</p> <p>ATTENTION! If you want to use this selftest option, you <u>must</u> connect the photo-cell <u>before</u> the limit switch setting and force adjustment, otherwise there will be no selftest in later use.</p>

Advanced Connectors

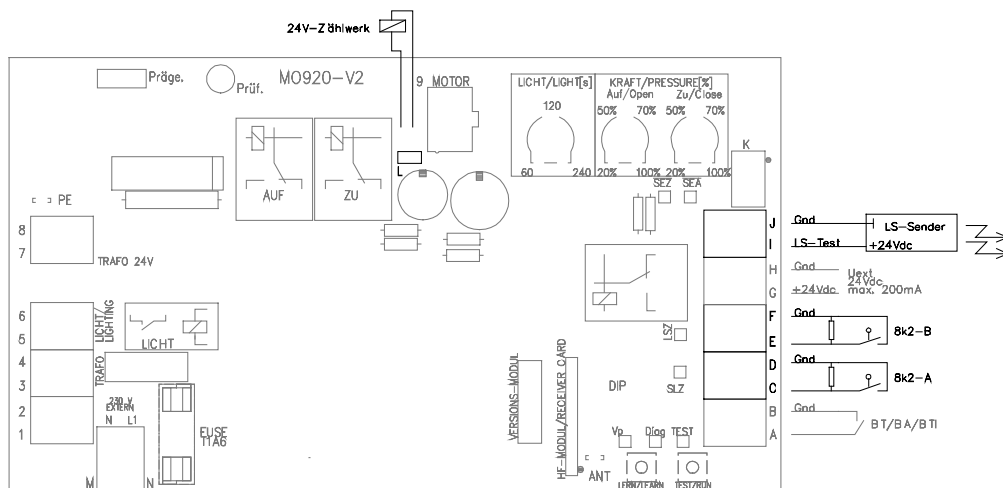

Security Beam and Hatch Door

E + F
(mit 8,2 kOhm Auswertung)

Function

OPENING direction: when releasing the CLOSING limit-switch the connector is checked for 3 seconds (= hatch door closed or opened). Impulses coming in later during the OPENING cycle will be ignored.
CLOSING direction: the connector is being checked throughout the whole CLOSING cycle. If an obstacle is recognized (by the security-beam) the operator will reverse (please also refer to chapter "Special Functions", paragraph "DIP-Switch 4", page 15).

Two devices may be connected to this connector:

1.) Security-Beam

This device is normally equipped with a 8.2 kOhm resistor. Therefore you have to remove the 8.2 kOhm resistor from the connectors E + F before connecting the security-beam.

2.) Hatch-Door Switch

A hatch-door within the garage door can be secured with a switch - when the switch is not activated (e.g. the hatch-door stands open) the operator will not work.

Security Beam (8,2 kOhm resistor connected in line):



Hatch-Door Switch (8,2 kOhm resistor connected in line):

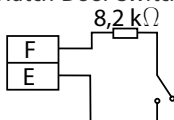

Security Beam and Hatch-Door (connected in line):

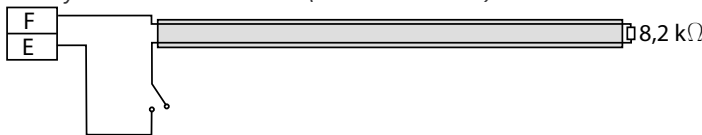

Modules for Special Functions

„Versions Module“

- Plug for optional modules providing special functions:
- Automatic Closing (AZ)
 - One-Way traffic control (EI) with traffic-light regulation
 - Dead-Man-Function (TO) (push-button needs to be pressed during the whole CLOSING cycle, otherwise the operator stops)

Cycle Counter

L A counter for OPENING/CLOSING cycles can be connected (24V)

LED-Lamps

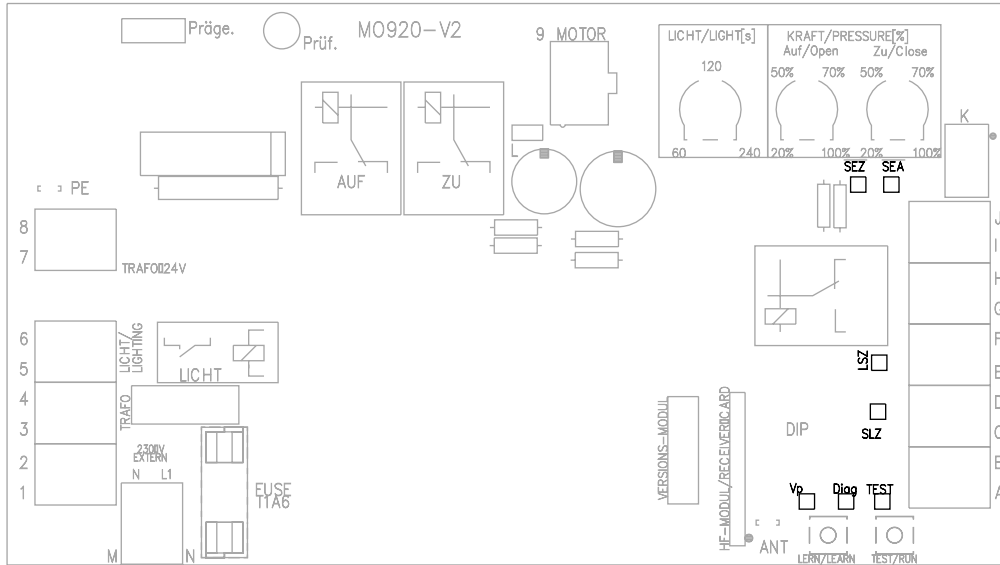

LED	Function	ON	OFF
LED "TEST"	"ON" when a device connected to A+B (push-button, key-switch) or the electronics' TEST-button gives an impulse	Incoming impulse	No incoming impulse
LED "Diag"	"ON" when an impulse from a programmed hand-transmitter is received. More functions of this LED are named in the chapters "Learning the force", "Remote-Control" and "Error messages".	Incoming impulse from a programmed hand-transmitter	No incoming impulse from a hand-transmitter
LED "Vp"	"ON" when mains power supply is o.k.	Mains power supply o.k.	No mains power
LED "SLZ"	Photo-Cell Possible Errors: - an obstacle is registered by the photo-cell - the connection wires might be broken or a short-cut was created - the photo cell is damaged - the 8.2 kOhm resistor is not connected properly	Error or obstacle	o.k.
LED "LSZ"	Security Contact / Hatch-Door Switch Possible Errors: - the security beam registers an obstacle - the hatch-door is open - the connection wires might be broken or a short-cut was created - Security beam or hatch-door switch is damaged - the 8.2 kOhm resistor is not connected properly	Error or obstacle	o.k.
LED "SEZ"	Checks the function of the CLOSING limit switch - when the limit switch is activated, the LED goes on. If it does not, then the limit switch is damaged.	activated	not activated
LED "SEA"	Checks the function of the OPENING limit switch - when the limit switch is activated, the LED goes on. If it does not, then the limit switch is damaged.	activated	not activated

Special Functions

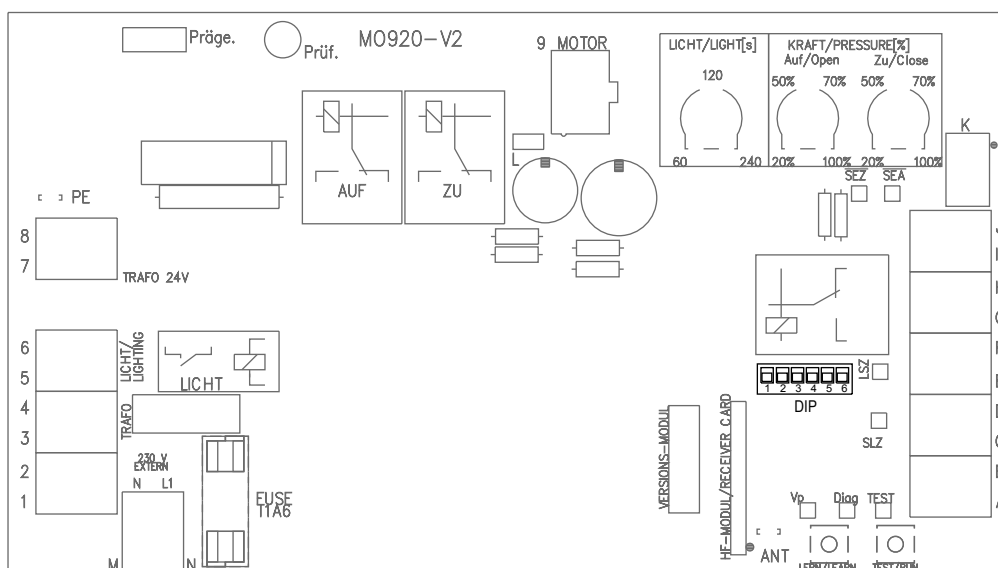

DIP-Switch Settings

DIP-Switch	Function	ON	OFF
1	<p>Automatic Force Measurement</p> <p>Standard setting: ON</p> <p>ATTENTION! In countries of the European Union the operator must be run with automatic force measurement - running it on manual force is illegal!</p> <p>In non-European countries the manual force may be used. Please pay attention to the fact, that the learning cycles (chapter "Limit-Switch Settings and Force Adjustment", pages 10+11) must also be done when manual force is chosen!</p>	Yes	No
2	<p>Additional Force</p> <p>Standard setting: ON</p> <p>For very light garage doors we recommend to set the switch to OFF</p>	Yes	No
3	<p>Pre-Warning light before every movement</p> <p>Standard setting: OFF</p> <p>When choosing ON a pre-warning of approx. 4 sec. will be made before each movement of the garage door.</p>	Yes	No
4	<p>Full reversion in OPENING direction</p> <p>Standard setting: ON</p> <p>The operator reverses approx. 20 cm when an obstacle in CLOSING direction is recognised. If the switch is set to ON the operator will reverse completely in OPENING direction until the OPENING limit switch is reached.</p>	Yes	No
5	<p>No reversion on Security-Beam when door closed</p> <p>Standard setting: ON</p> <p>This function is only needed when a security-beam is connected. In garages with an uneven floor the security-beam might lead to unwanted reversion when the garage door is almost closed. If the switch is set to ON the reversion in SOFT-STOP will be prevented - the operator simply stops and the door remains closed.</p> <p>HINT! Using this function might lead to problems programming new hand-transmitters via an existing hand-transmitter. For that programming the operator needs to hit the CLOSING limit-switch. Please also refer to chapter "Remote Control"</p>	Yes	No
6	<p>Side Hinged Doors</p> <p>Standard setting: OFF</p> <p>For use with a side hinged door the OPENING and CLOSING directions need to be reversed - setting this switch to ON will do that automatically.</p>	Yes	No

Programming the Hand Transmitters

Basics

As a standard the operator is equipped with a 433 MHz AM remote control set. The coding is done via rolling code - the code is changed after each impulse; receiver and transmitter agree completely automatic about the next code to be used. New codes will be chosen out of a pool of billions of possible codes.

Your operator is equipped with our standard remote control set when you hand transmitters looks like the one shown on the right hand side. The 4-channel MIDI transmitter is standard equipment, the 2-channel MINI transmitter is available as an optional.

If your operator is equipped with another remote control set, please refer to the manufacturers instructions for programming.

Programming Transmitter and Receiver

To use a hand transmitter it must first be registered (programmed) by the receiver. Only one hand transmitter button can be used for one receiver.

Registering the first hand transmitter

The first hand transmitter (e.g. no hand transmitter has been registered for the receiver, yet) must be learned directly via the operators' main electronic:

1. Press the LERN/LEARN button on the main electronic for approx. 3 seconds until the operator's light starts blinking and release the LERN/LEARN button.

2. Press the hand transmitter button you want to register to the receiver - the operators' light stops blinking when the transmitters' signal was received. The transmitter is now registered.

Registering additional hand transmitters

When at least one hand transmitter has been registered by the receiver you may program additional hand transmitters from a distance:

1. The garage door must be closed

2. Open the garage door approx. 50 cm and close it again.

3. After the garage door is closed you have got 10 seconds to press the buttons 1+2 simultaneously on the registered hand transmitter - the operator's light then starts blinking.

4. The light will keep blinking for another 10 seconds - during that period of time you must press the button on the new hand transmitter which you want to use with the operator. Once the new transmitter is registered the operator's light stops blinking.

The procedure must be repeated for each new hand transmitter.

Clearing the receivers' memory

Keep the LERN/LEARN button pressed for approx. 15 sec.. The operators' light and the red LED „Diag“ will start blinking after 3 seconds. After another 10 seconds the red LED „DIAG“ will glow constantly. You can then release the LERN/LEARN button.

All previously programmed hand transmitters are now cleared from the receivers' memory.

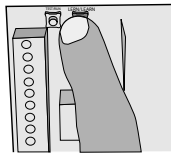
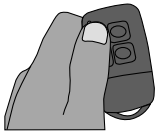
Quick reference: programming the first hand transmitter	
1.) Keep the LERN/LEARN button pressed for approx. 3 sec. 	The operators' light will start blinking
2.) Press the hand transmitter button you want to use 	The operators' light stops blinking - the transmitter was successfully programmed

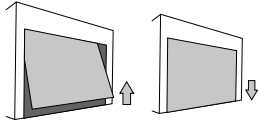
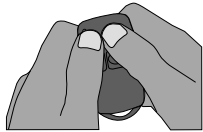
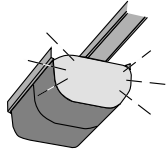
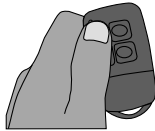
Quick reference: Programming additional hand transmitters from a distance	
<i>Remark: additional hand transmitters can be programmed either like the first transmitter or from a distance as explained below:</i>	
1.) Open the garage door for approx. 50 cm and close it again 	After the garage door is closed you have got 10 seconds to proceed to step 2)
2.) Press buttons 1+2 simultaneously on any registered transmitter for 3 sec. 	The operators' begins blinking - release the hand transmitters' buttons 
3.) Take the new hand transmitter and press the button you want to use shortly 	The operators' light stops blinking - the hand transmitter was successfully programmed

Additional Information

4-channel MIDI transmitter,
433 MHz, rolling code

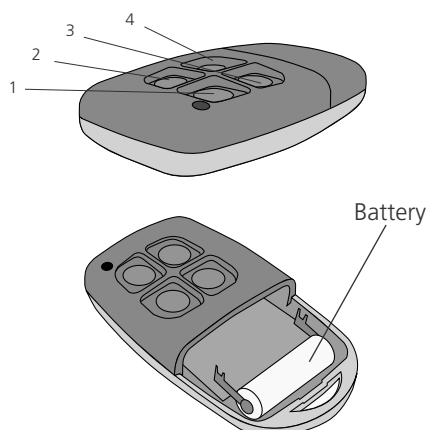

Usable types of batteries: A23, 23A, 23L, EL12, VR 22 and MN 21

Voltage: 12V

Used batteries must be disposed according to national laws!

2-channel MINI transmitter (optional extra),
433 MHz, rolling code

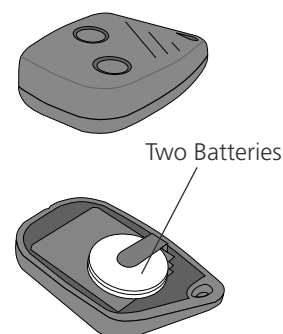

Two batteries, type CR1616 or DL1616 are required.

Voltage: 2* 3V (=6V)

Used batteries must be disposed according to national laws!

Criteria influencing the range

The TS operators are equipped with a high quality remote control set as a standard!

Nevertheless the remote control is the part of the operator which might be influenced by circumstances in the surroundings of the garage. With our standard remote control you might reach a range of more than 100 meters. In areas with high disturbances the range will still be approx. 50 meters.

The range might be influenced by:

- old batteries in the hand transmitter - if you should experience a problem with the range, please change the batteries first. The lower the batteries run the lower the range will be.

- Building materials of the garage
In a garage made of concrete and steel you might reach a lower range than in an ordinary garage build of stone. The more steel was used for the walls the shorter the range of your remote-control.

Remote-control activity in the area
Radio and television transmitters close to your garage might reduce the range.

Older baby-phones
Especially older baby-phones might influence the range of the remote control severely. These devices send strong signals via the houses internal power supply net. These signals also intrude other devices via the wall plug, as eg the operator.

It is extremely unlikely that the range will drop to an unacceptable distance. If, however, problems should occur we will like to be helpful.

Use with a HomeLink® System

The HomeLink® System is becoming more and more popular in private households. Most frequently it is being used in cars - the HomeLink® module is integrated in the car. It allows the driver to activate the door operator with a push of button which is installed in his car. Once programmed, the driver does not need the hand transmitter to access the garage with his car.

The standard remote control supplied with the TS-series is compatible with HomeLink® systems manufactured by end of year 2002 / beginning of year 2003 (subject to technical alterations).

The procedure how to program the HomeLink® device is described in the car's manual - please refer to those instructions. *(Basic information on programming: you first must register the hand transmitter with the operator. The HomeLink® system will then learn the code from the hand transmitter).*

Please avoid to drop the hand transmitter - parts could be damaged inside the transmitter. That might lead to malfunctions!

Technical Data

	TS 75	TS 100
Maximum Pulling Force (adjustable)	70 kg (+/- 4%)	100 kg (+/- 4%)
Force-Setting for Operation	automatic	automatic
Motor	24V DC, low-noise	24 V DC, low-noise
Running Speed	14,5 cm/sec.	14,5 cm/sec.
Speed in Soft Mode	8 cm/sec.	8 cm/sec.
Lighting	230V AC, max. 40 watts	230V AC, max. 40 watts
Lighting Durance (adjustable)	80 to 240 seconds	80 to 240 seconds
Duty Cycle	80%	80%
Power Consumption in Stand By	2,3 watts	2,3 watts
Power Supply	190-250V AC	190-250V AC
Transformer	230V AC, 24V DC	230V AC, 24V DC
Pre-Warning Light	adjustable	adjustable
Stop on Security Beam in Closing Direction	adjustable	adjustable
Automation of Side Hinged Doors	adjustable	adjustable
Nett Running Length	2.640 mm	2.640 mm
Max. Running Length with Extension	4.150 mm	4.150 mm
Overall Length	3.215 mm	3.215 mm
Height Motor Head	170 mm	170 mm
Length Motor Head	370 mm	370 mm
Width Motor Head	260 mm	260 mm
Minimum Space above the door	35 mm	35 mm
Weight including packaging	22 kg	

Optional Special Functions

For the TS-series operators we provide plug-on module cards for advanced functions:

Module "Automatic Closing" (AZ)

For automatic closing of the garage after an adjustable time from 80 to 240 seconds.

The card is also equipped with a connector giving an impulse for one second when the garage door is opened - an automatic external light can be connected here.

Special functions as "fast closing" (the garage door will be closed as soon as the car passed the photo cell) and "additional photo-cell in opening direction" are adjustable on the module-card.

Module "Separated Impulse" (TO)

The impulses for OPENING and CLOSING direction are given separately - one button will always OPEN the door and the other will allways CLOSE it. It can be adjusted so either direction will work on impulse or steady press of the button (e.g. the button needs to be pressed for the whole OPENING or CLOSING cycle - when the button is released the door stops)

Module "One Way Traffic Control" (EI)

A traffic control for narrow access to/from a garage. Red and green traffic lights can be connected.

Installation and User manuals are enclosed to the modules.

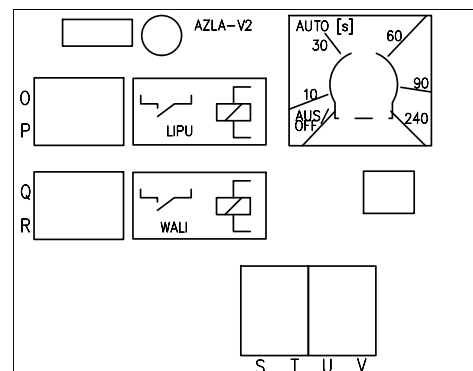

Sample: Modul for automatic closing with potentiometer for adjustment of the opening time.

Wiring

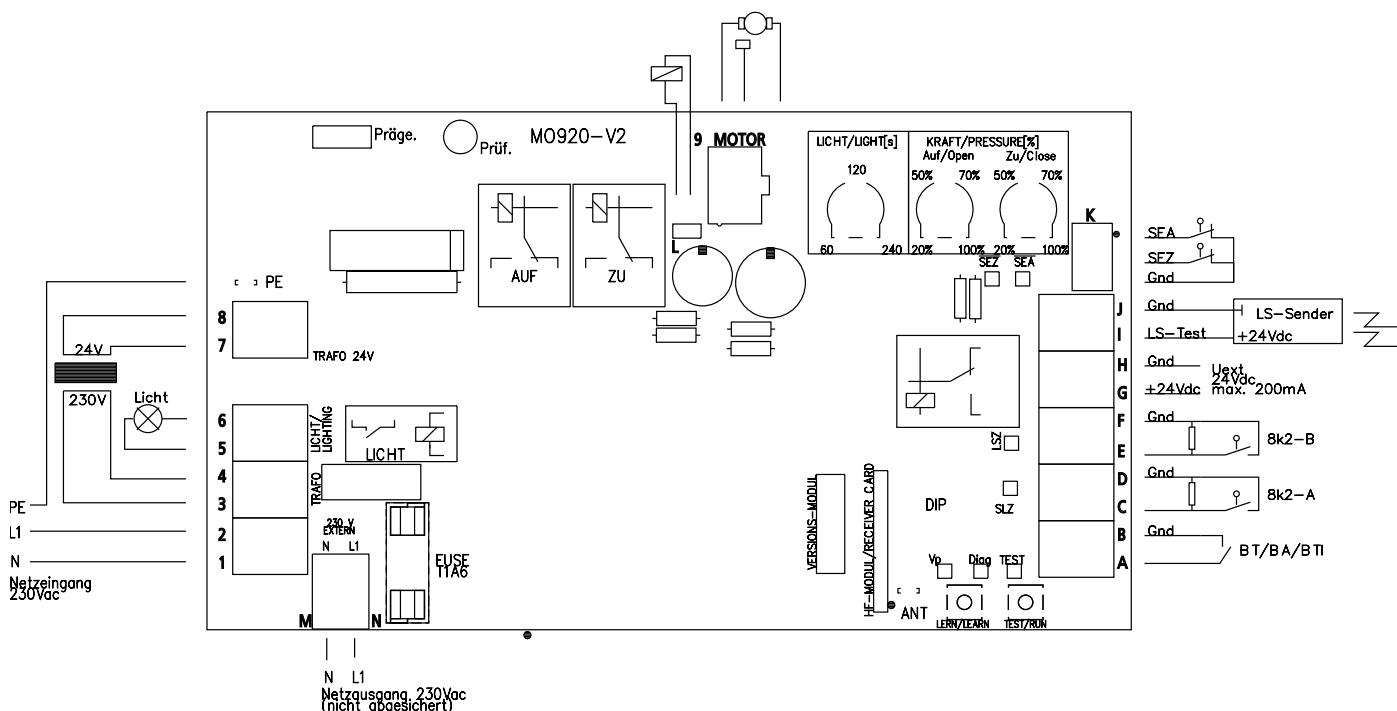

Internal Wiring

1	Blue, mains supply, 230V
2	Brown, mains supply, 230V
3	Black, transformer, 230V
4	Black, transformer, 230V
5	Brown, Lighting, 230V
6	Blue, Lighting, 230V
7	White, transformer, 24V
8	White, transformer, 24V
9 MOTOR	Connector for the plug from the motor
K	Connector for the plug from the limit switches
PE	Earthing from the printed circuit board to the base plate
Earthing of the mains supply	The earthing of the mains supply (green/yellow) is connected to the base plate with a screw (the screw is marked with an earthing symbol)

External connections

(Explained on pages 12 + 13)

A + B	Floating connector for push-button, key-switch and the impulse cables of an external receiver
C + D	Floating connector with a 8,2kOhm resistor for impulse cables from a photo-cell receiver
E + F	Floating connector with a 8,2 kOhm resistor for security beam and hatch-door switch
G + H	24V DC supply for external components (max. 200 mAmp.)
I + J	24V DC for a photo cell transmitter when a self test before every movement of the door is required
L	Connector for a cycle counter (24V) - all openings will be counted
M + N	230V AC for external components - not secured by the electronics. Shortcuts will blow the house fuse.

Devices for adjustments

Potentiometer „Licht/Light“	Adjustment of the time for the internal lighting (60-240 Sek)
Potentiometer „Force Open“	Adjustment of the maximum force for the opening direction
Potentiometer „Force Close“	Adjustment of the maximum force for the closing direction
Button „Test/Run“	Runs the operator - OPEN-STOP-CLOSE
Button „Lern/Learn“	For automatic force setting and registration of hand transmitters

Other

HF-Modul/Receiver Card	Plug for receiver module, 433 MHz
Versions-Modul	Plug for modules for special functions
FUSE	Fuse T1,6, 250V

Spare Parts

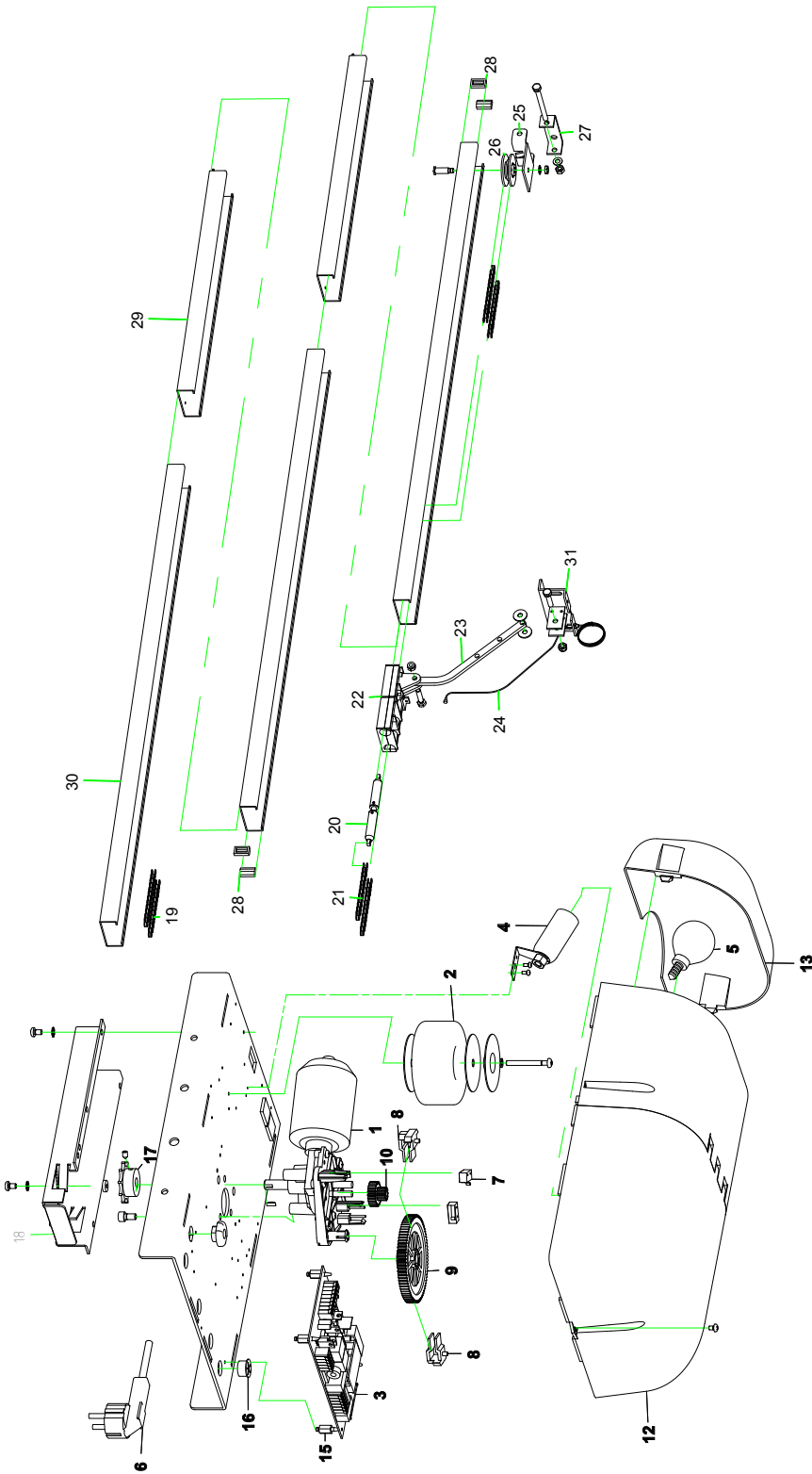

No.	Description	Stock-Code	No.	Description	Stock-Code	No.	Description	Stock-Code
1	Motor TS 75	PL1212	13	Light Cover	PI0005	19	Chain	PM0301
2	Transformer	PL1312	15	Threaded Distance Piece	PI0310	20	Chain Closing Link	PM0310
3	Printed Circuit Board	PL2006	16	Twisted Nipple	PI1311	22	Chain Tensioner	PH2200
4	Lampholder	PE05004	17	Pinion TS 75	PM11006	23	Carriage	PH2600
5	Light Bulb	PH2101-1	18	Pinion TS 100	PM11005	24	Door Arm	PH2403
6	Power Supply Cable	PJ0530		C-Shaped Part	PH1500	25	Bowden Cable	M07000
7	Limit Switch Unit	PI0450				26	Guide Pulley Holder	PM12002
8	Limit Switch Actuator	PH0830				27	Guide Pulley	PI0120
9	Spur Toothed Wheel	PI1200				28	Fixing Square	PM04003
10	Step Wheel	PH3201				29	Chain Guide Block	PI0502
12	Cover	PI0105					C-Profile Coupling Piece	PM1400
		PI0006					C-Rail, 1m	PH3000

Troubleshooting

Error Messages

The TS-series is equipped with a system of error messages via the internal lighting and the LED "Diag".

Error messages via the operator's light
2 x blinking
Limit switch error - either one of the limit switches is damaged or the relays on electronic board are damaged.
5 x blinking
Neither the OPENING limit switch nor the CLOSING limit switch were reached. The operator is switched off. Check the limit switch settings and start a new learning cycle.
8 x blinking
The microprocessor has lost data - try to run the learning cycle. When this does not work, the electronics need to be exchanged.
9 x blinking
Error on the electronic board - the electronics need to be exchanged.
10 x blinking
Damaged relays - the electronics need to be exchanged
11 x blinking
Error on a module for special functions - change the module. If the error still occurs the main electronics must be exchanged.

Additional messages only via the LED "Diag"
3 x blinking
Photo cell - either an obstacle was recognised by the photo cell or the photo cell is damaged. Please also check the photo cells wiring.
4 x blinking (only with special function module "AZ" running in French mode)
Photo cell for opening direction - either an obstacle was recognized by the photo cell or the photo cell is damaged. Please also check the photo cells wiring.
6 x blinking
Photo Cell - either an obstacle is within the photo cell's range or the photo cell does not work properly.
7 x blinking
Security Beam or Hatch Door Switch - either an obstacle is inbetween the devices or the device does not work properly

If... then...

The operator does not react on the transmitter or on the push-button switch

Power failure? Disconnect and connect the operator. Is the door stuck because of snow and ice? Check the lines and the connections of the push-button switch. Is there water in the push-button switch or in the key operated switch? Disconnect alle external components and try running the operator via the TEST/RUN button.

The operator reacts on the transmitter but not on the push-button switch

Check the line of the push-button switch. Does the push-button switch work, when the remote receiver is disconnected? If so, the remote transmitter or receiver might be defective.

The operator reacts on the push-button switch but not on the transmitter

Check the accordance of the transmitter and the receiver code. Displace the antenna of the receiver. Avoid each metal contact (reduces the range). Check the battery of the transmitter

The operator reacts on the push-button switch but not on the transmitter

Change the code of your remote control (of transmitter and receiver). Disconnect the receiver or remove the transmitter battery. Use your push-button switch only. If this solves the problem, your sender may be defective. Disconnect the push-button switch and use your transmitter only. If this solves the problem, the push-button switch or the line of the push-button switch may be defective.

The door doesn't open completely

Is the limit switch „OPEN“ correctly set? Is the door jamming while opening? Unlock the carriage manually (make the door running well). Lubricate and oil the pivotal points of the door. Increase the power.

The door doesn't close completely and opens again

Is the limit switch „CLOSE“ set correctly? Is the door jamming while closing? Unlock the carriage manually (make the door running well). Lubricate and oil the pivotal points of the door. Run through the automatic learning cycle.

The emergency release doesn't work

Is the limit switch „CLOSE“ correctly set? If not, your opener switches off under pressure. In this case the chain is under tension and therefore the emergency release can hardly be unlocked. Make sure that the limit switch is correctly set.

The light doesn't work

Replace the bulb (230 V, max. 40 Watt)

The operator isn't running smooth

Unlock the carriage of the opener. Move the door manually and make sure that the door is well balanced (must come to a stop at each position). The spring tension is too high or there is even a spring fracture.

The motor is buzzing but the door doesn't move

The door is jamming.

The operator works, but the door doesn't move

The carriage is unlocked. If you want to lock it, open the door, but not completely, and let the opener run. The carriage locks in automatically.

The operator doesn't work because of a power failure

Unlock the carriage with the help of the emergency release and open the door manually. (If you have a garage where you can only enter from outside: Unlock the door with the key and turn the door-handle, then your opener will be unlocked. If you have a garage where you can also enter from inside: pull at the Bowden cable hanging from the carriage.)

EC Declaration of Conformity
 Low-Voltage Directive 73/23/EEC
 and amendments
 Electro-Magnetical Compatibility 89/336/EEC
 and amendments

Document No. AN-16062003
 Dokument Nr. AN-16062003



We,
 Wir,

Seip Antriebstechnik GmbH
Grombacher Straße 83, 75045 Walzbachtal-Jöhlingen, Deutschland

hereby declare, that the following products comply to the mentioned EC-regulations.
*erklären hiermit, daß die nachfolgenden genannten Produkte den unten angegebenen
 EG-Richtlinien entsprechen.*

Type of Product / Produktart	Garage Door Operator / Torantrieb
Product Name / Modell	TS 75, TS 100
Approved according to 89/336/EEC and 73/23/EEC / Geprüft nach 89/336/EWG und 73/23/EWG Referring EC-regulations: / Angewandte harmonisierte Normen:	
Electromagnetic Compatibility / Elektromagnetische Verträglichkeit	EN 61000-3-2:2000 Limits for harmonic current emissions / <i>Grenzwerte für Oberschwingströme</i> EN 61000-3-3:1995 + Corrigendum:1997 + A1:2001 Limitation of voltage changes, voltage fluctuations and flicker in publik low-voltage supply systems / <i>Grenzwerte für Spannungsschwankungen und Flicker</i> EN 61000-6-3:2001 Emission standard for residential, commercial and light-industrial environments / <i>Störaussendung für Wohnbereich, Geschäfts- und Gewerbebereiche sowie Kleinbetriebe</i> EN 61000-6-2:2001 Generic standards - Immunity for industrial environments <i>Fachgrundnorm - Störfestigkeit - Industriebereich</i>
Low-Voltage Directive / Niederspannungsrichtlinie	EN 60335-2-95:2001-7 Particular requirements for drives for vertically moving garage doors for residential use / <i>Anforderungen für Antriebe von Garagentoren mit Senkrechtbewegung zur Verwendung im Wohnbereich</i> EN 60335-1:1994 + A1:1996 + A2:2000 + A11:1995 + A12:1996 + A13:1998 + A14:1998 + A15:2000 + A16:2001 Safety of household and similar electrical appliances / <i>Sicherheit elektrischer Geräte für den Hausgebrauch</i>
Safety in Use / Nutzungssicherheit	EN 12453:2000 Safety in use of power operated doors, requirements / <i>Nutzungssicherheit kraftbetätigter Tore, Anforderungen</i> EN 12445:2000 Safety in use of power operated doors, Test methods / <i>Nutzungssicherheit kraftbetätigter Tore, Prüfverfahren</i>

Peter Seip, Geschäftsführer, Walzbachtal-Jöhlingen, 16.06.2003



Grombacher Straße 83
 75045 Walzbachtal-Jöhlingen
 Germany
 www.seip.com

EC Declaration of Conformity
in accordance with the Radio and Telecommunications
Terminal Equipment Act (FTEG) and Directive 1999/5/EC
(R&TTE Directive)

EG-Konformitätserklärung
gemäß dem Gesetz über Funkanlagen und Telekomm
unikationsendeinrichtungen (FTEG) und der Richtlinie
1999/5/EG (R&TTE)

Document No. FU-16062003
Dokument Nr. FU-16062003



We,
Wir,

Seip Antriebstechnik GmbH
Grombacher Straße 83, 75045 Walzbachtal-Jöhlingen, Deutschland

declare that the product
erklären, daß das Produkt

SKR 433

Code B43A023004

Hand Transmitter as remote control for garage door operators
Handsender als Fernbedienung für Garagentorantriebe
(Short Range Device)
(Funkgerät geringer Reichweite (SRD))

complies with the essential requirements of §3 and the other relevant provisions of the FTEG (Article 3 of the R&TTE Directive), when used for its intended purpose.
bei bestimmungsgemäßer Verwendung den grundlegenden Anforderungen des §3 und den übrigen einschlägigen Bestimmungen des FTEG (Artikel 3 der R&TTE) entspricht.

§3(1)1, (Article 3(1)a) does not refer to this type of product.
§3(1)1, Artikel 3(1)a bezieht sich nicht auf diesen Produkttyp, es gibt hierzu keine Norm

Protection requirement concerning electromagnetic compatibility §3(1)(2), (Article 3(1)(b))
Schutzanforderungen in Bezug auf die elektromagnetische Verträglichkeit §3(1)2, Artikel 3(1)(b))

EN 300 220-1/1997
EN 300 683/1997
EMV / EMC Directive 89/336/EEC;92/31/EEC;93/68/EEC

A handwritten signature in black ink that reads 'Peter Seip'.

Peter Seip, Geschäftsführer, Walzbachtal-Jöhlingen, 16.06.2003

Seip
ANTRIEBS | TECHNİK

Grombacher Straße 83
75045 Walzbachtal-Jöhlingen
Germany
www.seip.com

