

Installation- and Operating Instructions

Swing gate operator SLIM S/C





GENERAL WARNING- AND SAFETY NOTES

- These installation- and operating instructions form an integral part of the product “gate operator”. They have been specifically written for professional installers trained and skilled in the trade and should be carefully read in their full length before carrying out the installation. They describe the proper installation and operation of the sliding gate operator only, not of the overall device “automatic gate”. After the installation this manual has to be handed over to the user.
- Installation, connection, adjustments, putting into operation, and servicing may only be carried out by trained professionals in full accordance with these installation- and operating instructions.
- Before carrying out works at the gate-system, the power supply has to be turned off.
- The EU Machine Directive, laws and rules concerning the prevention of accidents, and laws and standards which are in force in the EU and in the individual countries have to be strictly followed.
- The TOUSEK Ges.m.b.H. cannot be held liable for any claims resulting from disregards of the laws and standards in force during the installation and operation.
- The packaging materials (cardboard, plastic, EPS foam parts and filling material etc.) have to be properly disposed of in accordance with the applying recycling- and environmental protection laws. They may be hazardous to children and therefore have to be stored out of children’s reach.
- The product is not suitable for installation in explosion-hazardous areas.
- The product may only be used in accordance with its original purpose, for which it has been exclusively designed, and which is described in these installation and operating instructions. Especially children have to be instructed accordingly. The TOUSEK Ges.m.b.H. rejects any liability if the product is used in any way not fully conforming to its original purpose as stated herein.
- Before beginning with the installation the installer has to make sure that all mechanical components of the gate facility, like carrier profile/rail, gate frame and panels, guiding elements etc. are sufficiently supportive and resistant for the purpose of gate automation.
- All electrical installations have to be made in full conformity with the applying rules and laws (e.g. using a fault current circuit breaker, proper grounding etc.).
- An all-pole disconnecting main switch with a contact opening-gap of minimum 3 mm has to be foreseen.
- The electric motor heats up during operation. Therefore the device should only be touched after it has cooled off.
- After installation the proper function of the gate facility and the safety devices has to be checked!
- The TOUSEK Ges.m.b.H. rejects any liability for claims resulting from usage of the product in combination with components or devices which do not fully conform to the applying safety laws and rules.
- Only original spare- and replacement parts may be used for repair of the product.
- The installer has to inform the user about all aspects of the automatic operation of the complete gate facility, as well as about emergency operation. The installer further has to supply to the user all instructions relating to the safe operation of the gate facility. The installation and operating instructions also have to be handed over to the user.
- **Please notice that the warranty will not be applicable if the label with the engine number has been removed or damaged.**



Maintenance

- **Maintenance works may only be carried out by qualified personnel.**
- **Check the proper power adjustment once a month.**
- **Check the proper function of the emergency release mechanism periodically.**
- **Check if all mounting screws are securely fastened periodically.**
- **Remove dirt deposits from the operator and gear rack periodically.**
- **Apply the grease HSW100 at the pivot points of the operator and spray the push rod with silicone spray (twice a year or as needed).**
- **Maintenance and servicing of the complete gate facility has to be carried out according to the gate builder’s/ installer’s instructions.**

Features Swing gate operator SLIM S/C

- for 12V d.c.
- max. weight of gate wing 150 kg
- suitable for later installation on existing gates
- incl. installation hardware (stainless steel)
- self-locking steel spindle
- for private applications (approx. 20 cycles/day)
- 



General characteristics

The TOUSEK SLIM permits a simple and quick automation of new or already existing swing gates.

The electromechanic operator consists of a powerful DC motor and a stainless steel push rod with integrated self-locking spindle. All components are contained in an anodized aluminium housing.

In case of e.g. a power failure the operator can be disengaged with the help of an emergency key, permitting a manual operation of the gate wing. In addition the electronic control can be supplemented with an emergency backup rechargeable battery. Due to the self locking spindle of the operator normally no electric lock is required to provide a secure locking of the gate wing. Depending on the particular situation at the gate facility, however, an electric lock may be required in some cases to guarantee a reliable locking of the gate wing in its closed position.

The operators **SLIM SLR** and **SLIM CLR** are additionally equipped with integrated limit switches.

Technical specifications

Swing gate operators SLIM-	SR	SLR	CR	CLR		SR	SLR	CR	CLR
supply voltage	12Vd.c.				self-locking in OPEN gate position	■	■	■	■
max. current consumption (ST12/5)	6A				self-locking in CLOSED gate position	■	■	■	■
max. gate wing width	2,5m				mechanical system	■	■	■	■
max. gate weight	150kg				force-adjustment through control unit	■	■	■	■
max. thrust	1800N				built-in limit switches		■		■
piston -/spindle-travel	330mm				emergency release	■	■	■	■
operating factor in operating mode S3	20/Tag				ambient temperature	-15°C to +40°C			
piston speed at 12Vd.c.	16mm/s		13mm/s		article code	11260250	11260260	11260270	11260280



Note: Max. wing widths do neither apply to full-panel gates (but to stave or trellised gates) nor to non-horizontal gates !



Attention

- Before beginning the installation of the operators, please make sure that the gate wings are already limited in their travel by some sort of stopping devices both in the open (EO) and closed (EG) gate positions. If this is not the case, such stopping devices have to be installed or the Tousek piston rod stroke limiting device has to be used.

Note:

The operators SLIM SLR and SLIM CLR are equipped with integrated limit switches. It is nevertheless recommended to foresee a floor stop, especially in closed position.

- On thin-walled or wood-panel gate leaves the connector bracket must not be mounted directly on the gate leaf. In these cases a flat steel plate must be installed to support the connector bracket.
- *) **Attention: To avoid pollution and guarantee a long-lasting reliable operation, a distance of at least 400 mm has to be kept towards the upper edge of the roadway.**
- The installation positions for the front (1) and rear (2) mounting parts have to be determined with regard to the measurements A and B in the below chart. Pay attention to the horizontal alignment of the operator.
- At determining the mounting positions moreover pay attention to the fact, that the push rod **must not travel out its whole length during operation (at least 5mm have to remain).**

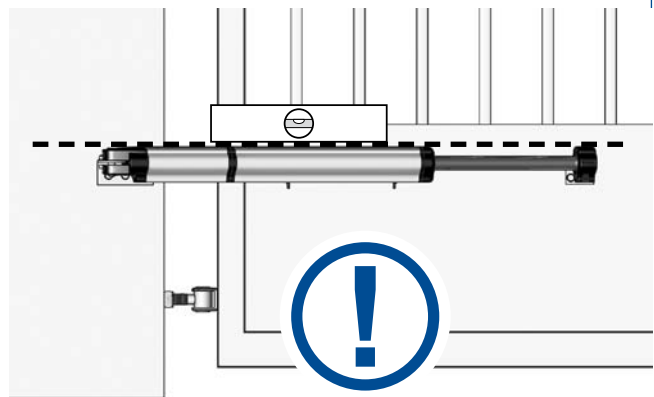
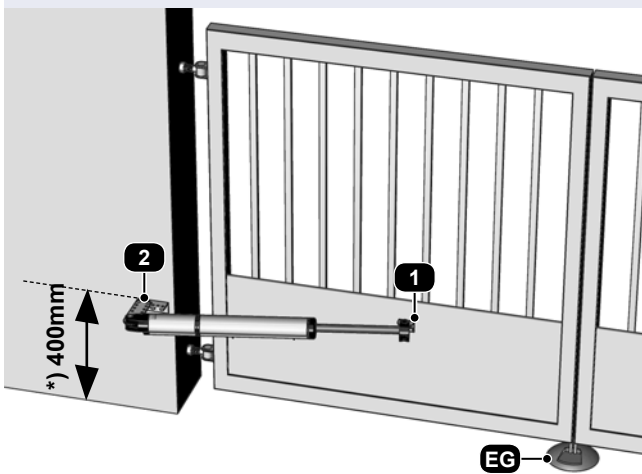

Attention

- The rear mounting part (2) is adjustable in two directions. A movement of part (2a) towards y, requires a shortening of this part.

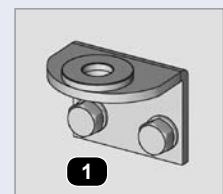
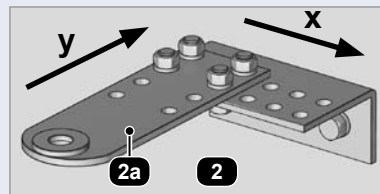

2a. Mounting positions

Installation



Important

- The installation positions for the front (1) and rear (2) mounting parts have to be determined with regard to the measurements A and B in the beside chart. Pay attention to the horizontal alignment of the operator.
- **The distances A and B always have to be measured from the pivoting point of the gate.**

Swing gate operators SLIM S/C	inside swinging		outside swinging
max. wing width	2,5m	2,0m	2,5m
A (mm)	150	100	150
B (mm)	140	150	140
C (mm)	1095	1095	780
opening angle (Grad)	95°	120°	95°

inside swinging gate wing
(Center of rotation in line with center axis of gate wing)

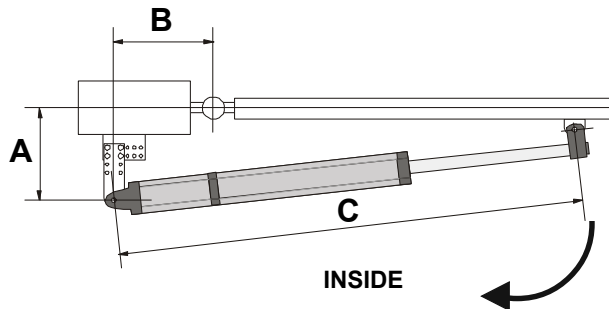

inside swinging gate wing
(Center of rotation not in line with center axis of gate wing)

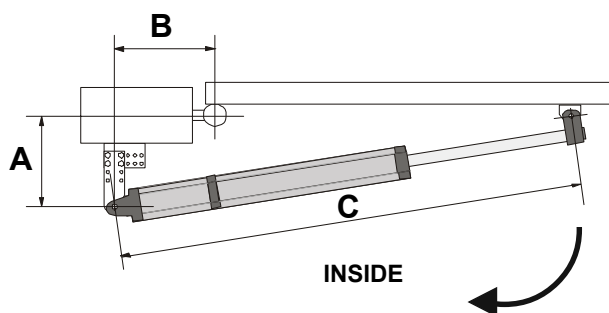

Special case - outside swinging gate wing

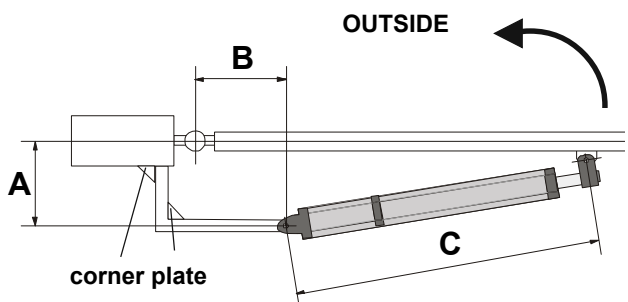

Note: In order to increase the strength of the connections we recommend reinforcing the welding brackets with corner plates.

Installation on larger gate columns



Note

- On larger gate columns and inside swinging gate leaves a recess according to the illustration below has to be made. This will help you keeping the distances A, B.
- **Note:** The recess in the gate column has to be big enough to make sure that the electrical supply cable of the operator will not be buckled.

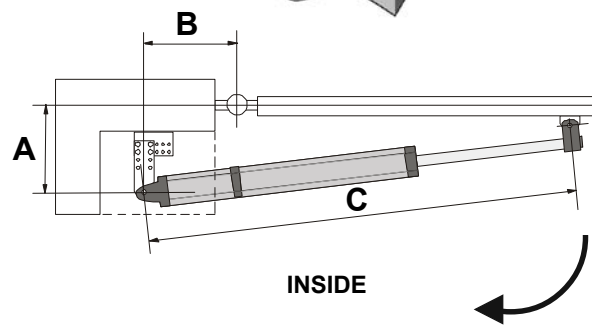
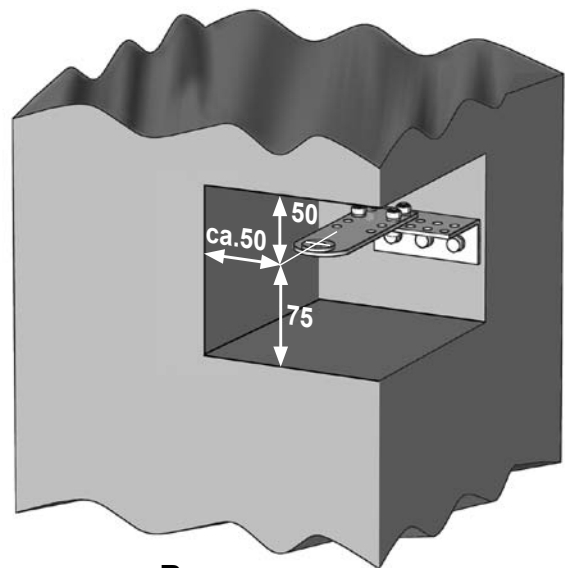

Installation of the rear mounting part

- After having determined the pivoting point of the operator with regard to the measurements A and B please mount the rear mounting part (2) at this position on the gate column (wall).

Installation of the front mounting part

- Connect the front mounting part (1) to the gate leaf, keeping the distance C. Please make sure that the gate is fully closed and that the operator will be mounted horizontally.
- On thin-walled or wood-panel gate leaves the connector bracket must not be mounted directly on the gate leaf. In these cases a flat steel plate must be installed to support the connector bracket.



Important

- The operator piston rod must not travel out its whole length (at least 5 mm have to remain)! Thus the travel of the gate wing has to be limited by floor stoppers, or the Tousek piston rod stroke limiting device has to be used.



Important

- The operator always has to be installed with the rear cable inlet facing downwards.
 - After installing the mounting parts the operator itself can be mounted. Before, grease the mounting parts at their pivot points, as well as the push rod (in extended position)!
 - Therefore set the operator (A1) motor-sided on the rear mounting part (2) and insert the longer one of both cylindrical bolts (Z2) as well as the cover (D) from above.
 - Open the hexagon socket screw (K1) and put the clamping piece (K) on the push rod (A2). Position the clamping piece exactly on the circular nose of the push rod and tighten the hexagon socket screw.
 - Now insert the clamping piece (K) in the front mounting part (1) and insert the cylindrical bolt (Z1) and the cover (D) from above.
- Note: The push rod can be brought in the desired position by turning it.
- Tighten the hexagon socket screw (K1).

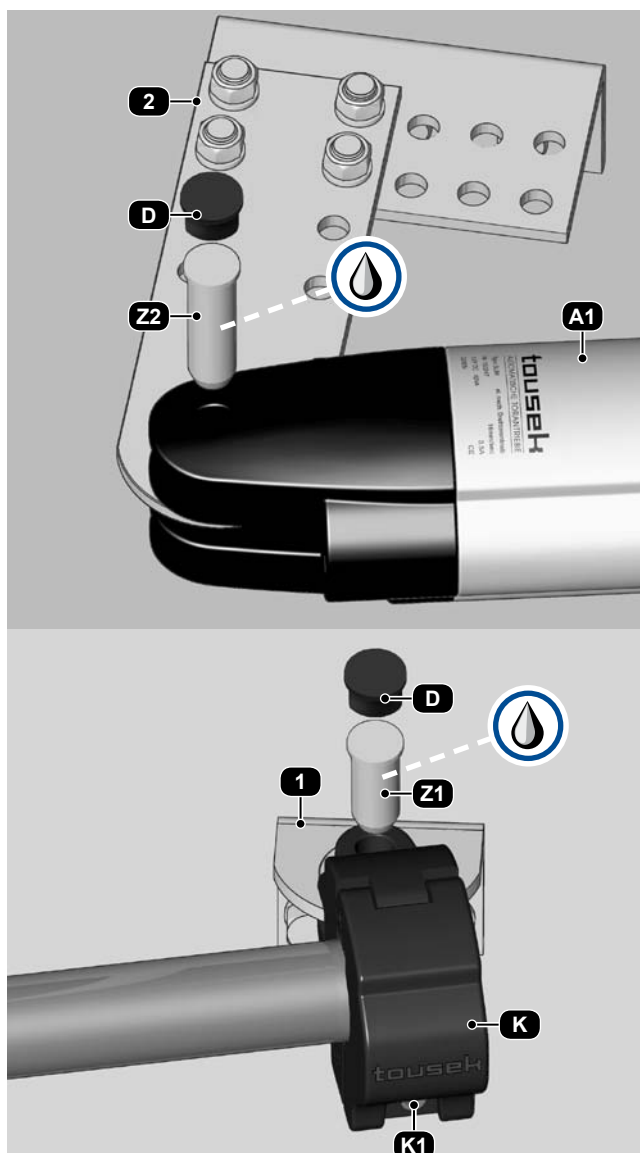
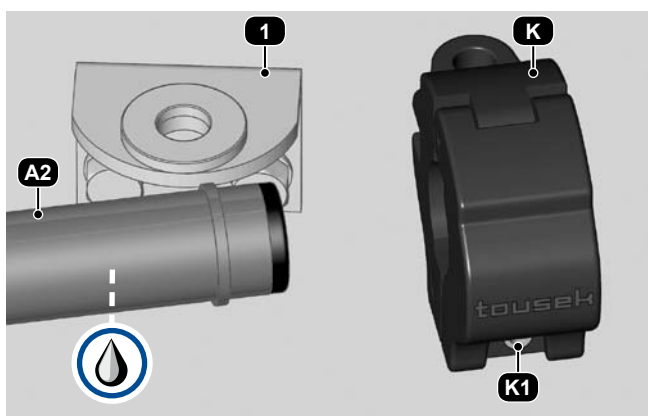

Greasing of the moving mounting parts and of the push rod

- All the pivot points (the drills of the mounting parts and the corresponding bolts, which allow a defined mounting of the actuator) have to be lubricated before mounting the automation, e.g. with multifunctional spray WD-40!
- Also spray the push rod (in extended position)!
- Let the automation run two or three times (open and close it)
- Grease the automation regularly (according to the maintenance instructions).

2c. Electric connections and force adjustment

- Before carrying out the electrical connections, the power supply of the gate facility must be turned off.
- Connect the operator according to the manual of the control.
- Connect various safety devices, impulse emitters and other accessories according to their manuals (pay attention to the cable plan).
- The force adjustment of the operator is carried out in the control (see control manual).



Attention

- At connection-, adjustment and maintenance works please make sure, that the electronic printed circuit board is not damaged by moisture (rain).
- At force adjustment the valid standards and safety regulations must be kept.

- The operator types **SLIM SLR** and **SLIM CLR** are equipped **with limit switches**. It is nevertheless recommended to foresee floor stops, especially in position "gate closed". The adjustment of the end positions is done with the limit switches for positions "gate opened" and "gate closed" which are on the underside of the operator (by moving them laterally). For adjustment please see *manual of control*.
- All other operator types work **without limit switches**. The control turns the motors off automatically, when they reach their end positions (by current measurement). Floor stops have to limit the travel of the gate in opened as well as in closed position.

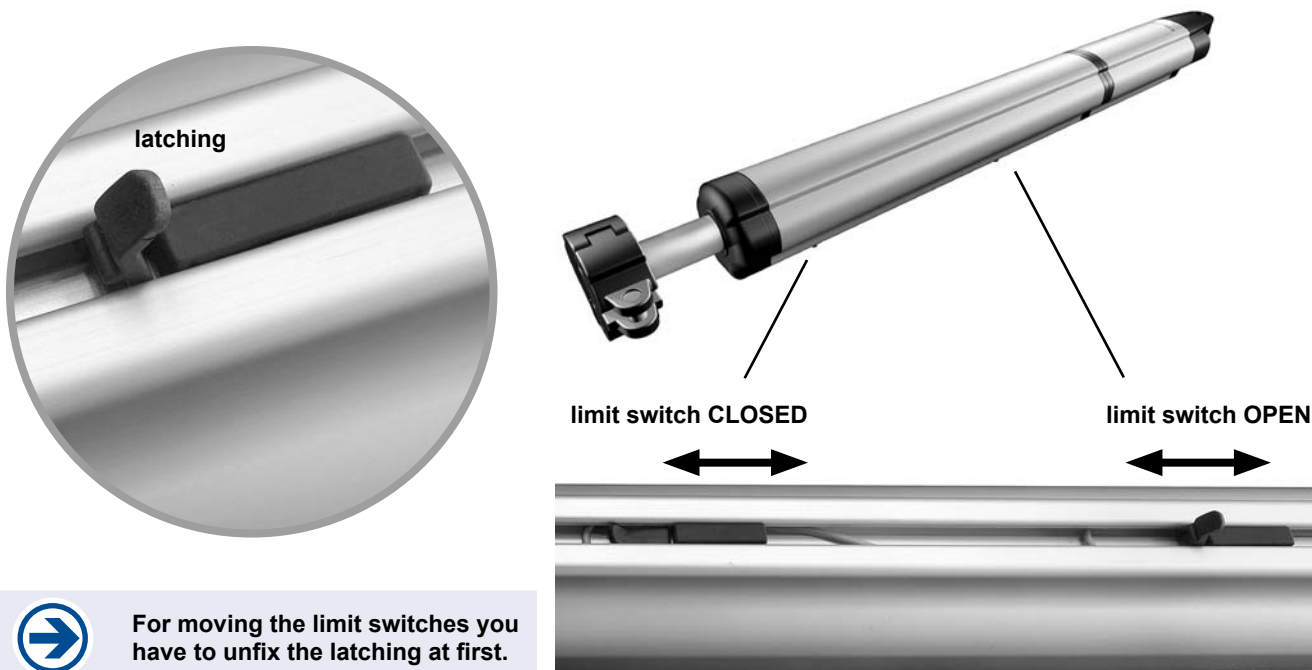

2e. Dismounting the operator

Dismounting the motor is done in the reverse mounting order.



It has to be taken care, that the power supply of the operator is turned off before dismounting!

3. Emergency release in case of power failure

Swing gate operator SLIM S/C

Basically, the control unit can be equipped with an optional emergency backup battery which keeps the gate operational also in case of power failures. Should it become necessary to disengage the operator please follow the below steps:

- Open the hexagon socket screw (**K1**) so far, that you can open the clamping piece a bit and move out the push rod.
- Now push rod and gate are no longer connected and the gate can be operated manually. Move the gate slowly (not faster than in motor operation).
- To return to motor operation insert the push rod in the opening of the clamping piece and tighten the hexagon socket screw.

Before tightening please make sure, that the clamping piece is positioned at the circular nose of the piston rod.

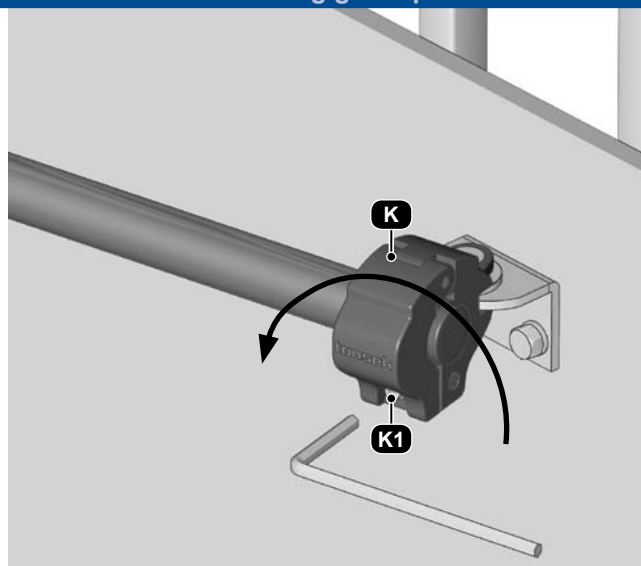

- 1 operator Tousek SLIM S/C
- 2 electronic logic control ST12/4
- 3 external fotocell
(T: transmitter, R: receiver)
- 4 internal fotocell
(T: transmitter, R: receiver)
- 5 pushbutton momentary contact switch
- 6 key-operated momentary contact switch
- 7 signal light
- 8 radio remote receiver, *) included into the logic control box on the „ST“-models)
- 9 antenna (connection to radio receiver with coaxial cable)
- 10 main power switch and fuse 6 A
Note: An all-pole disconnecting main switch with a contact opening-gap of minimum 3 mm has to be foreseen
- 11 safety sensing edges
- 12 electric lock
- 13 hinged locking bar
- 14 floor stops
- 15 connection box

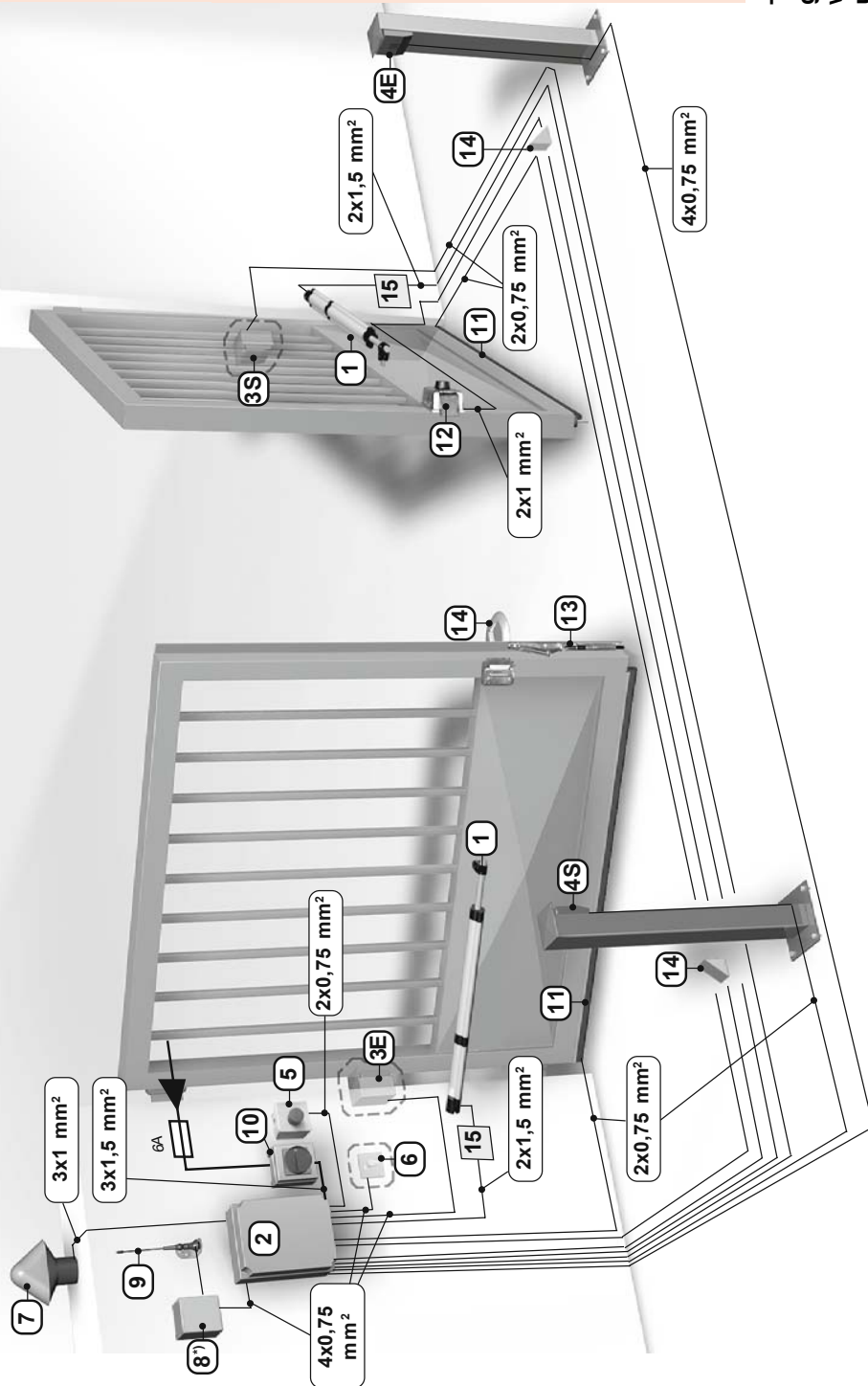

NOTE concerning cable laying

The electric cables have to be laid in insulating sleeves which are suitable for underground usage.

230 V cables and control lines have to be laid in separate sleeves.

Only double-insulated cables, which are suitable for underground usage (e.g. E-YY-J) may be used.

In case that special regulations require another type of cable, cables according to these regulations have to be used.

SAFETY NOTE

Please be aware that the beside picture is only a symbolic sample illustration of a gate facility and may therefore not show all safety devices required for your specific application.

To achieve an optimum safety level at your gate facility, please make sure that all safety components and accessories which - according to the applying safety rules and laws - are required in your particular case (e.g. photocells, induction loops, sensing edges, signal lamps, traffic lights, mains- and emergency power off switches etc.) are properly installed, operated, and serviced.

In this context please follow the EU Machine Directive, accident prevention rules and laws, as well as applying EU- and national standards in force at the time of installation and operation of the gate facility.

The Tousek Ges.m.b.H. cannot be held responsible for any consequences resulting from disregard of applying standards and laws during installation or operation of the gate facility.

The 0,75mm² control lines are shown without ground lead. In order to facilitate connections we recommend using flexible wires and not using thicker wires for the control lines.

10. Dimensioned drawing

- dimensions in mm

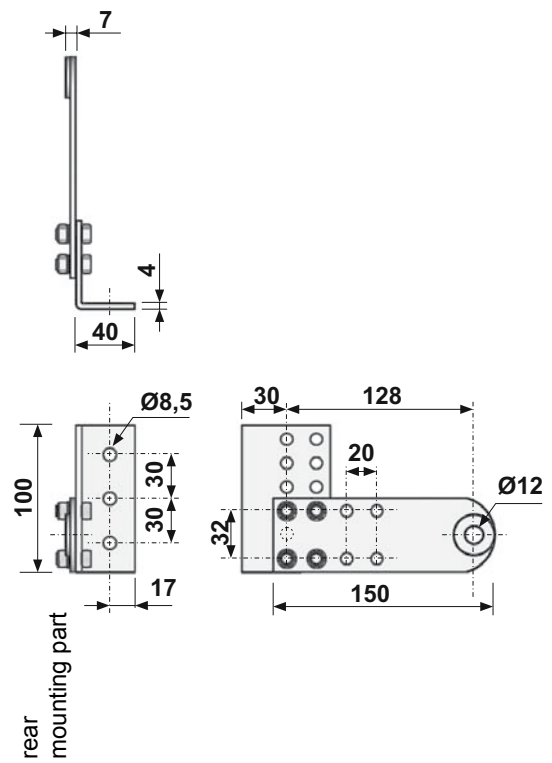
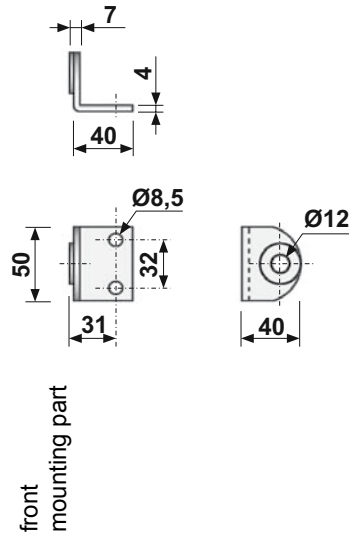
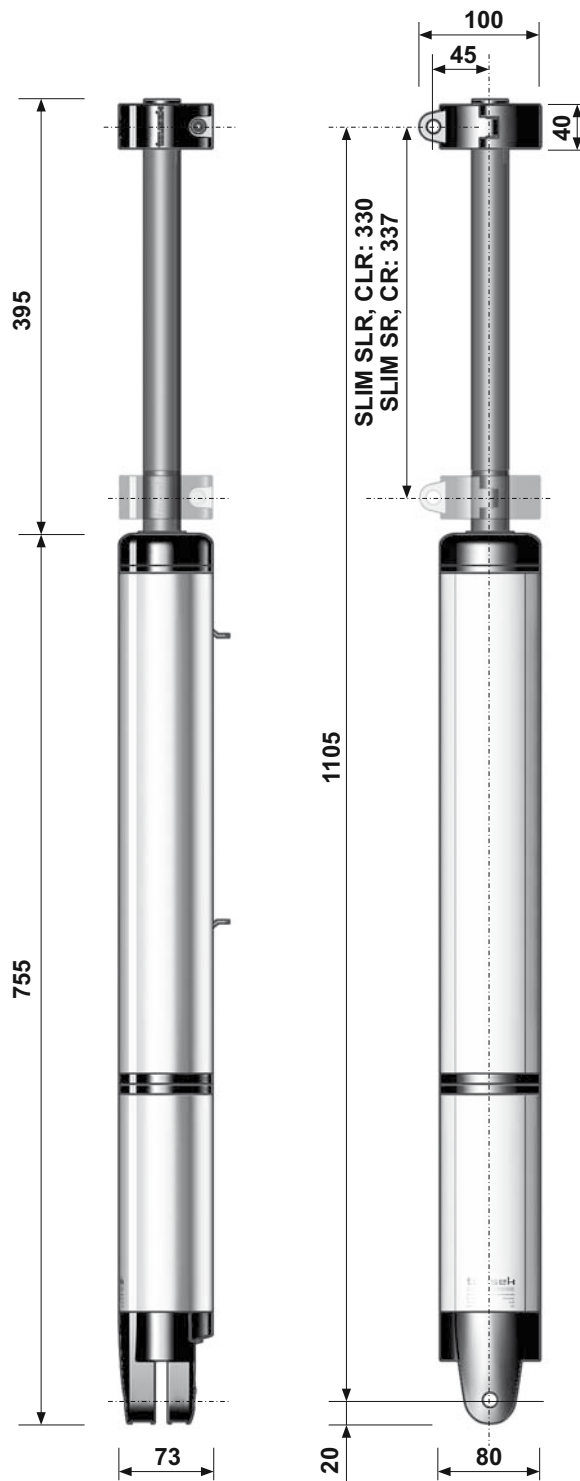

We reserve the right to change dimensions and technical specifications without prior notice.

Declaration of incorporation

In compliance with EC Machine Directive 2006/42/EC, Annex II B for the installation of an incomplete machine.

We hereby declare that the following product, as well as its version, put by us into circulation, complies with the essential requirements of the Machinery Directive (2006/42/EC), due to its design and type of construction.

The validity of this declaration will cease in case of any unauthorized modifications to the products.

The product:

Swing gate operator SLIM SLR, SLIM CLR

is developed, designed and manufactured in accordance with:

Machinery Directive 2006/42/EG
Low Voltage directive 2006/95/EG
Electromagnetic compatibility 2004/108/EG

Applied and used standards and specifications:

EN ISO 13849-1, PL-„c“
EN 60335-1
EN 60335-2/95
EN 61000-6-3
EN 61000-6-2

Following requirements of Annex I of the EC Directive 2006/42/EC are met:

1.1.2, 1.1.3, 1.1.5, 1.2.1, 1.2.2, 1.2.3, 1.2.6, 1.3.2, 1.3.4, 1.3.7, 1.5.1, 1.5.4, 1.5.6, 1.5.8, 1.7

The relevant technical documentation is compiled in accordance with Annex VII, Part B of the EC Machinery Directive 2006/42/EC.

We undertake to submit it in electronic form and within a reasonable time to the market surveillance authorities in response to a duly substantiated request.

TOUSEK Ges.m.b.H., A1230 Wien, Zetschegasse 1, Österreich

is authorized to compile the technical documentation.

The incomplete machine cannot be put into service, until it is determined that the machine, into which the incomplete machine has to be inserted, complies with the the Machine Directive 2006/42/EC.



Eduard Tousek, CEO

Vienna, 01. 01. 2013



EC Declaration of Conformity

In compliance with EC Machine Directive 2006/42/EC, Annex II, Part 1 A.

When the described operators are connected to a gate they form a machine in the sense of the EC Machine Directive.

Relevant EU directives:

Construction Products Directive 89/106/EWG
Machinery Directive 2006/42/EG
Electromagnetic compatibility 2004/108/EG
Low Voltage directive 2006/95/EG

We hereby declare that the following product, in the version put by us into circulation, complies with the essential requirements of the Directives mentioned above. The validity of this declaration will cease in case of any unauthorized modifications to the products.

Product:

Gate description

Motor description

The incomplete machine cannot be put into service, until it is determined that the machine, into which the incomplete machine has to be inserted, complies with the the Machine Directive 2006/42/EC.

Installation company

Address, ZIP code, Place

Date/ Signature

Motor number (Type plate): _____

Other components:

tousek PRODUCTS

- sliding gate operators
- cantilever systems
- swing gate operators
- garage door operators
- folding door operators
- traffic barriers
- carpark management system
- window operators
- domelight operators
- sliding door operators
- electronic controls
- radio remote controls
- key operated switches
- access control
- safety devices
- accessories

Tousek Ges.m.b.H. Austria
A-1230 Vienna
Zetschegasse 1
Tel. +43/ 1/ 667 36 01
Fax +43/ 1/ 667 89 23
info@tousek.at

Tousek GmbH Germany
D-83395 Freilassing
Traunsteiner Straße 12
Tel. +49/ 8654/ 77 66-0
Fax +49/ 8654/ 57 196
info@tousek.de

Tousek GmbH Switzerland
CH-6275 Ballwil
Bahnhofstraße 14
Tel. +41/ 0/ 41 448 2965
Fax +41/ 0/ 41 448 2966
info@tousek.ch

Tousek Benelux NV
BE-3930 Hamont - Achel
Buitenheide 2A/ 1
Tel. +32/ 11/ 91 61 60
Fax +32/ 11/ 96 87 05
info@tousek.nl

Tousek Sp. z o.o. Poland
PL 43-190 Mikołów (k/Katowic)
Gliwicka 67
Tel. +48/ 32/ 738 53 65
Fax +48/ 32/ 738 53 66
info@tousek.pl

Tousek s.r.o. Czech Republic
CZ-130 00 Praha 3
Jagellonská 9
Tel. +420/ 2/ 2209 0980
Fax +420/ 2/ 2209 0989
info@tousek.cz

tousek
E_SLIM-SR-CR_42000903
30. 08. 2016



your service partner:

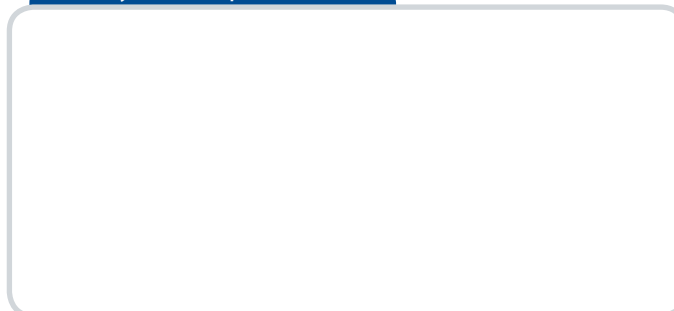

We reserve the right to change dimensions and/or technical specifications without prior notice. Claims resulting from misprints or errors cannot be accepted.

