

Connection and installation guide for the Intratone caretaker call panel GSM / PSTN



Presentation

This guide describes connecting the INTRATONE caretaker call panel ® - GSM/PSTN to an INTRATONE central unit ®.

Important notes

EC standards:

- The panel complies with **the R&TTE Directive 1999/5/EC**: electrical **safety standard EN 60950 (2001) applied**, EMC standard **EN 301 489-3 (2002) applied**,

Cabling:

- -The cables connected to the central unit must not be placed in the vicinity of other sources of electrical power (e.g. mains power supply).

Operating warranty

- The panel is guaranteed to operate within a temperature range of between -20°C and $+70^{\circ}\text{C}$ in which relative humidity does not exceed 70%.

End of life product recycling:



The panel and its accessories must not be disposed of with unsorted municipal waste, but must follow the WEEE (Waste Electrical and Electronic Equipment) collection and recycling channel.



Caretaker call panel models

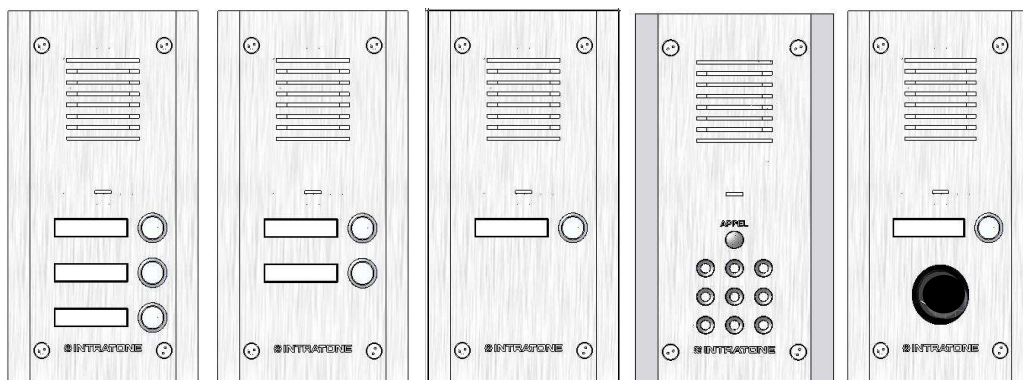

Card description

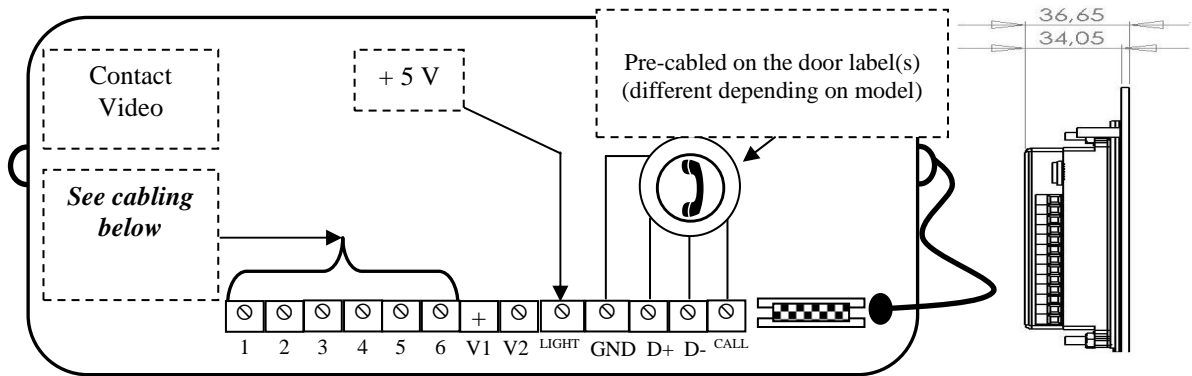

Cabling with a central unit connected to a GSM unit

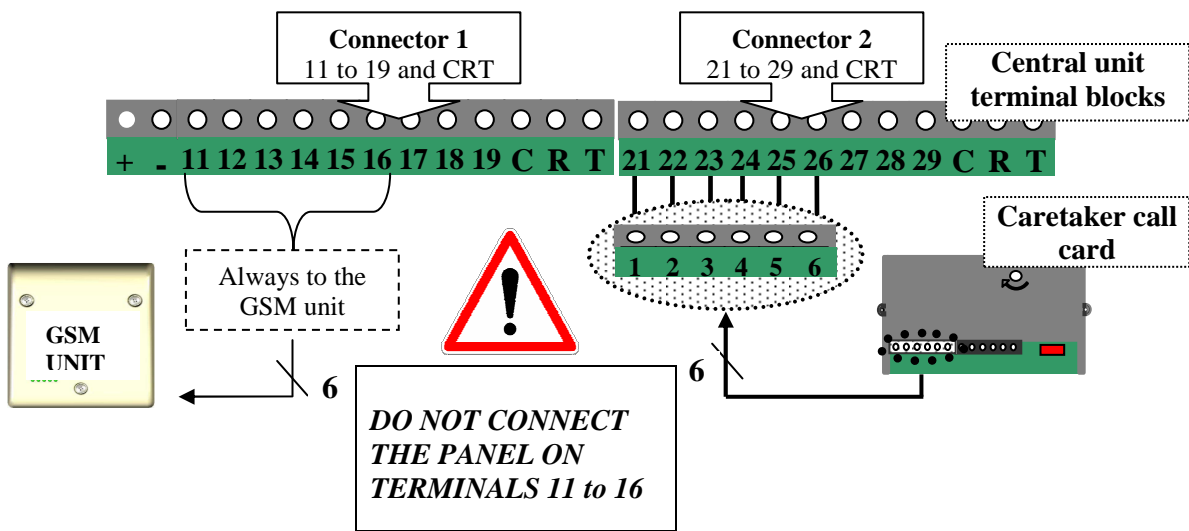

Cabling with a central unit connected to a PSTN line

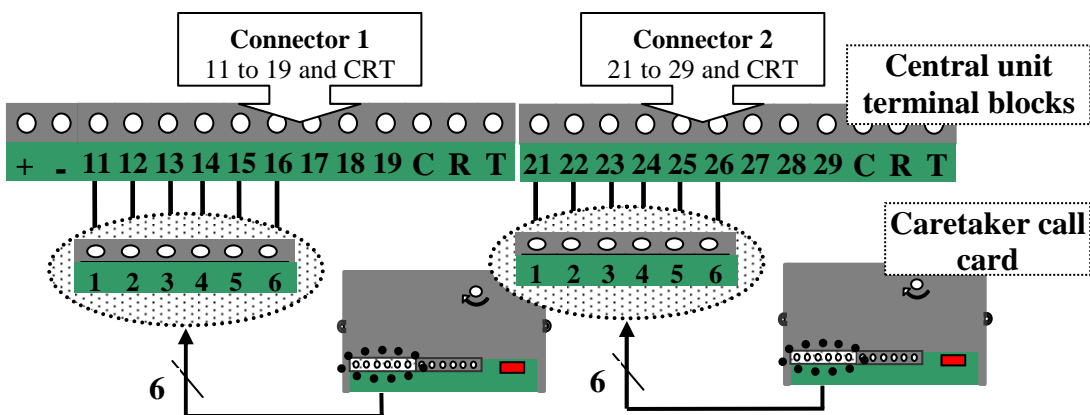

Note:

- You can add an extension board to the central unit to increase the number of doors controlled.
- A surface mounting box is also available. Check with your dealer.

Sizes

**Caretaker
call panel**

