

GATE HARDWARE ESSENTIALS 2026

t: 01384 569 942 | e: info@easygatesdirect.co.uk

RollingCenter[®]
INNOVATIVE SOLUTIONS FOR METAL GATES AND DOORS



With over 25 years experience in the industry, EG Direct is the largest electric gate automation supplier in the Midlands. Our reputation in the gate automation world is renowned, and we supply and support very large national automation companies throughout the UK. Our knowledge and experience makes us the first choice in supplying access control and gate automation products. We have a highly skilled team of technical advisors who can assist and support with any enquiry. We are constantly monitoring the market to ensure that we stay ahead of the competition, in technology, quality, and service.



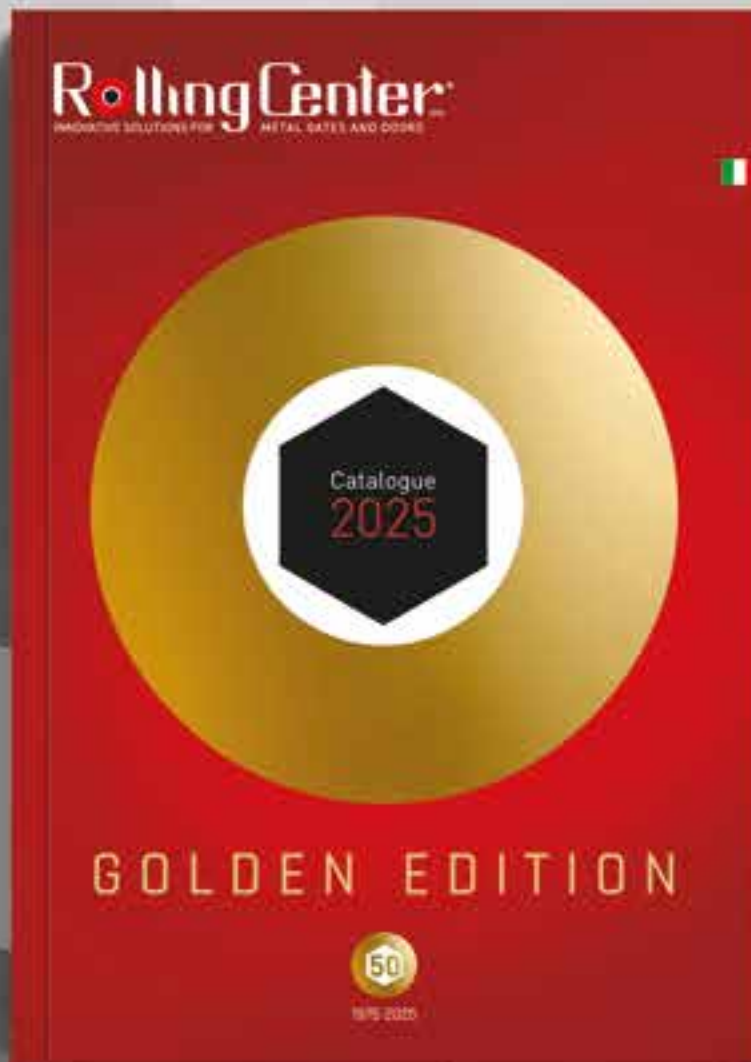

Complete Rolling Center Hardware Catalogue

290 pages, available upon request

CONTENTS

SLIDING GATE WHEELS	4
SLIDING GATE TRACK	5
SWING GATE HINGES	6
CANTILEVER GATE KITS	7
CANTILEVER ACCESSORIES	12

Wheels



8300 / 10300 / 12300

STANDARD WHEEL WITH TWO BEARINGS (TO SUIT 20MM TRACKS)

Article	D	d3	A	B	C	F	LxHxS	Capacity
Reference	∅		mm	0		UNI	mm	KG
8300	80	60	30	44	21	M14x70	80x50x3	250
10300	100	80	30	44	21	M14x70	100x50x3	300
12300	120	100	30	44	21	M14x70	100x50x3	350

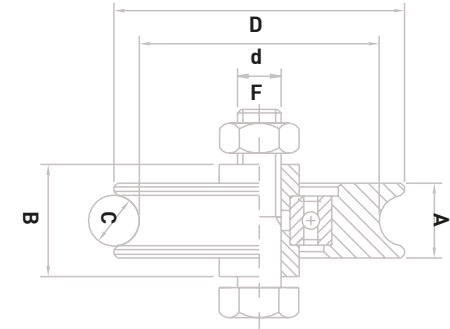

826PSO / 1026PSO / 1227PSO

WHEEL WITH TWO BEARINGS & SUPPORT (TO SUIT 20MM TRACKS)

Article	D	d3	A	B	C	G	I	E	S	L	Wheelbase	Capacity
Reference	∅		mm		0	mm						KG x 1
826 PSO	80	60	26	34	21	58	12	11	3	140	117X∅9	200
1026 PSO	100	80	26	34	21	68	12	21	3	140	117X∅9	260
1227 PSO	120	26	26	38	21	88	12	21	3	140	150X∅9	350

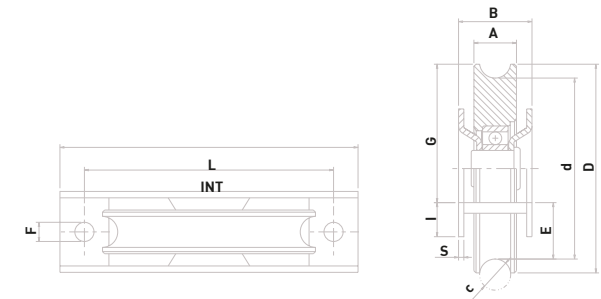

827PCO / 1030PCO

WHEEL WITH CLOSED BRACKET & TWO BEARINGS (TO SUIT 20MM TRACKS)

Article	D	d3	A	B	C	G	S	L	Wheelbase	Capacity
Reference	∅		mm		0	mm				KG x 1
827 PCO	80	62	26	36	21	82	3	120	90 x ∅9	190
1030 PCO	100	80	30	38	21	106	3	140	108 x ∅9	300

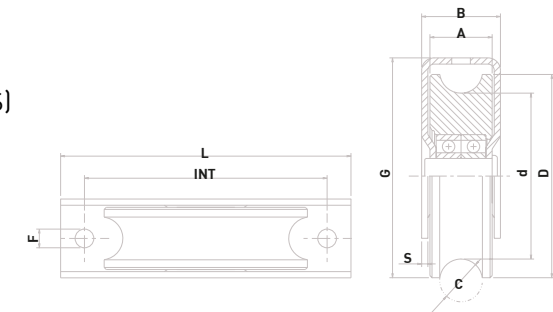

Sliding Gate track



FLOOR Z3

3M SURFACE FIT SLIDING GATE TRACK 20MM ROUND FOR O GROOVE WHEELS

Formed from one continuous piece of 3.5mm structural grade steel. Better suited to application where welding to other steelwork is required. Also available in a V profile.

Article	Description	L	S	KG
Reference		ML	mm	
FLOORZ3	Zincata	3	3,5	500

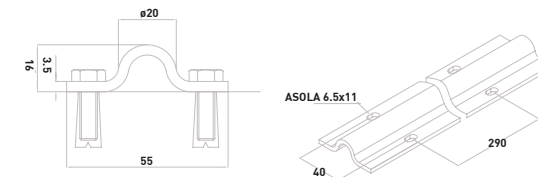

SISTEMA Z3

3M CONCRETE DOWN SLIDING GATE TRACK 20MM ROUND FOR O GROOVE WHEELS

Concrete-in ground track for sliding gates and industrial doors, 20mm round for O groove wheels, supplied in modular 3m lengths, galvanised finish. Multiple lengths are precisely aligned using the 53 alignment joint pin supplied separately.

Article	Description	L	S	KG
Reference		ML	mm	
SISTEMA Z3	Track Galvanised	3	3.5	700

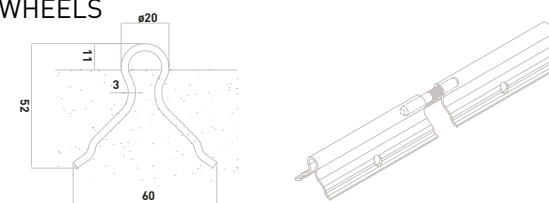

NEW OMEGA Z3

3M CONCRETE DOWN SLIDING GATE TRACK 20MM ROUND FOR O GROOVE WHEELS

Concrete down ground track for sliding gates and industrial doors, 20mm round for o groove wheels, supplied in modular 3m lengths, galvanised finish. 1.5mm steel body below concrete with 3mm hard carbon steel top rail.

Article	Description	L	S	KG
Reference		ML	mm	
NEWOMEGAZ3	Galvanised	3	3,5	1200

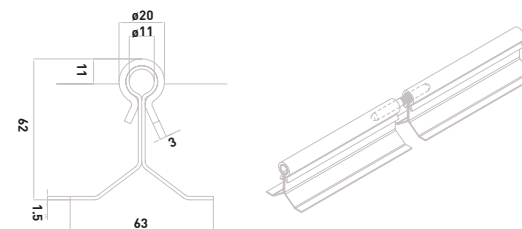

HEAVY Z3

3M FLUSH LAY CONCRETE DOWN SLIDING GATE TRACK 20MM ROUND FOR O GROOVE WHEELS

Flush-lay concrete in ground track for heavy sliding gates and industrial doors, 20mm solid round bar for O groove wheels, in 3m modular lengths, galvanised. Alignment bracket supplied separately 53/1

Article	Description	L	S	KG
Reference		ML	mm	
HEAVY Z 3	Galvanised	3	3,5	3000

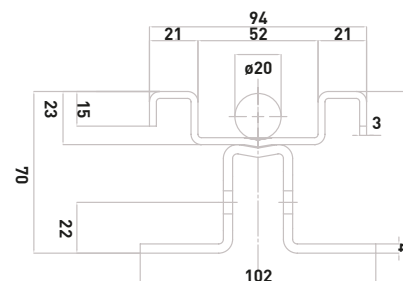

Sliding Gate Accessories



50 RP/ 50RS

ADJUSTABLE SLIDING GATE KEEP

Reference	A	lxl	L	WEIGHT
50 RP	40 ÷ 80	20 x 60	60	1.2KG
50 RS	80 ÷ 150	50 x 60	80	1.32KG

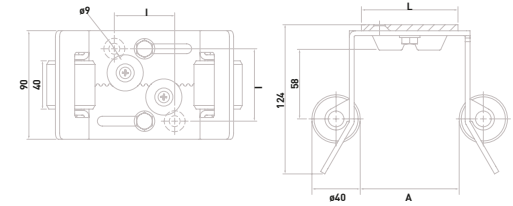

CN30 / CN32 / CN40 / CN42

CYLINDRICAL NYLON ROLLER WITHOUT PROTECTION

REFERENCE	D Ø	H	L Ø	F (thread)	WEIGHT
CN 30	30	40	71	M 14	0.144 KG
CN 32	32	40	71	M 14	0.148 KG
CN 40	40	60	96	M 20	0.385 KG
CN 42	42	60	96	M 20	0.395 KG

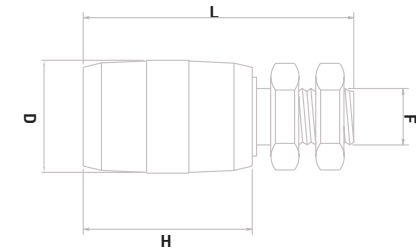

RNF40 / RNF48 / RNF60 / RNF80

NYLON ROLLER WITH BEARING

REFERENCE	D Ø	A	F (thread)	NUT Ø	LE	L	WEIGHT
RNF 40	40	15	M 14 x 40	17	8	64	0.13 KG
RNF 48	48	15	M 14 x 40	17	8	64	0.14 KG
RNF 60	60	19	M 20 x 40	22	13	72	0.31 KG
RNF 80	80	23	M 20 x 40	22	10	73	0.42 KG

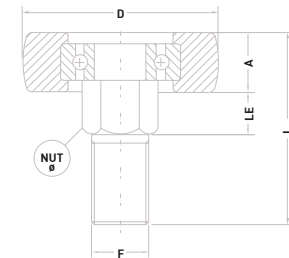

47 / 47/A2

1M & 2M STEEL GEAR RACK WITH WELD FIXING

REFERENCE	FINISH	A	B	L	MOD	WEIGHT
47	Galvanised	30	12	1005	4	2.4 KG
47/A2	Galvanised	30	12	2010	4	4.7 KG

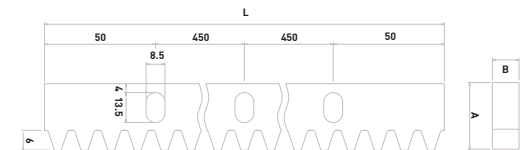

63/4

1M NYLON GEAR RACK WITH FASTENINGS

ARTICLE	REFERENCE	MATERIAL	L	MODULE	WEIGHT
63/4	GP 30 20 A1	Nylon	ML1	4	0.85 KG

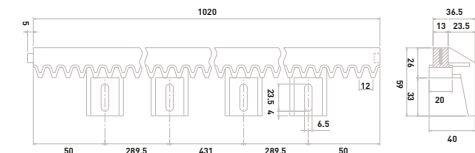

Hinges & Pins



CR30 / CR35 / CR40

ADJUSTABLE WRAP-AROUND HINGE HINGES WITH FLANGE NUT

Article	D	D1	F	F1	G min/max	I	S	A
Reference	∅		UNI		mm			
CR 30	28	30	M20	M10	50 - 78	22	6	15
CR 35	34	35	M24	M10	57 - 88	26	6	17
CR 40	36	40	M30	M12	70 - 110	34	6	24

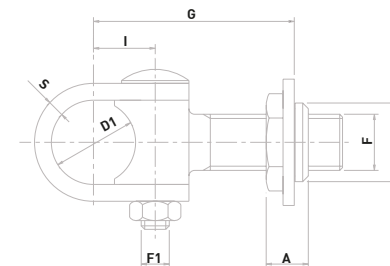

CR30P / CR35P / CR40P

ADJUSTABLE WRAP-AROUND HINGE WITH FIXING PLATE

Article	L	D	1F	F1	G min/max	I	S	A	D1	INT.
Reference	□	∅	UNI		mm				∅	mm
CR 30P	100	30	M20	M10	39 - 63	22	6	20	9	70
CR 35P	120	35	M24	M10	45 - 74	26	6	20	11	90
CR 40P	120	40	M30	M12	70 - 110	34	6	20	11	90

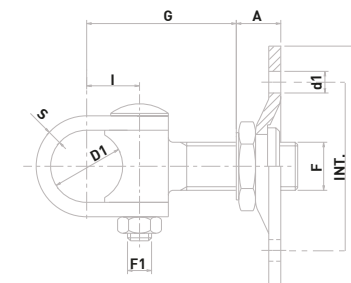

T30 / T35 / T35/80 / T40 / T40/90

UPRIGHT GATE JOINT PIN FOR WRAP-AROUND HINGE, TO WELD

Article	D2	A	B	C	Article	D2	A	B	C
Reference	∅	mm			Reference	∅	mm		
T 30	28,5	35	35	55	T 35/80	33,5	40	80	60
T 35	33,5	40	40	60	T 40/90	38,5	50	90	65
T 40	38,5	50	45	65					

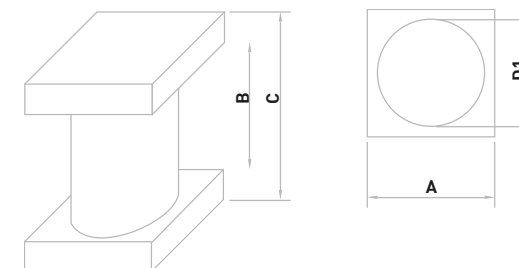

CR 50 / CR 60

ADJUSTABLE HINGE FOR HEAVY GATES WITH BEARING

REFERENCE	C	H	G MIN / MAX	I	S	L	CAPACITY	WEIGHT
CR 50	50	72	95 - 150	45	10	100	500 KG	2.1 KG
CR 60	60	85	100 - 155	50	12	110	680 KG	3 KG



Hinges & Pins



PG51S / PG71S

TOP ROTATING HINGE WITH WELD ON PLATE

REFERENCE	D Ø	d Ø	A	C	H	B	L	S	G (min/max)	CAPACITY (kg)	WEIGHT
PG 51S	50	23	25	10	43	50	80	8	48 / 60	450	0.6 KG
PG 71S	70	32	32	11	51	70	120	8	80 / 95	1000	1.48 KG

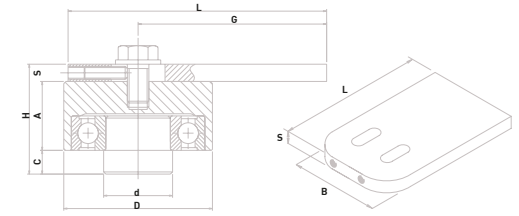

PG50I / PG70I

BOTTOM ROTATING HINGE TO WELD ON

REFERENCE	D Ø	d Ø	H	CAPACITY (kg)	WEIGHT
PG 50I	50	8	31	1000	0.40 KG
PG 70I	70	10	35	2500	0.87 KG

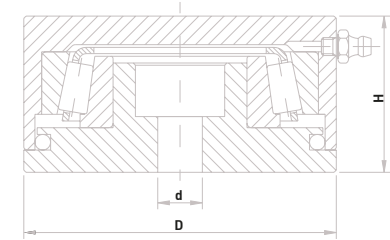

PG51S2 / PG71S2

TOP ROTATING HINGE WITH BOLT ON PLATE

REFERENCE	D Ø	d Ø	A	H	B	L	C	S	G (min/max)	CAPACITY (kg)	WEIGHT
PG 51 S2	50	23	25	43	50	80	70	8	52 / 64	400	0.74 KG
PG 71 S2	70	32	32	51	70	100	80	8	65 / 80	800	1.65 KG

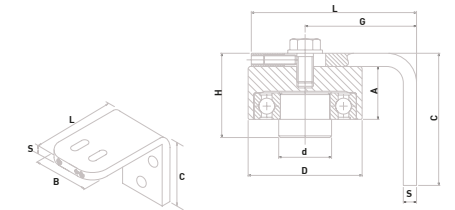

PG50I2 / PG70I2

BOTTOM ROTATING HINGE WITH BOLT ON PLATE

REFERENCE	D Ø	A	C	H	B	L	S	G (min/max)	CAPACITY (kg)	WEIGHT
PG 50 I2	50	31	70	40	80	80	8	52 - 64	200	0.75 KG
PG 70 I2	70	35	80	60	100	100	10	65 - 80	300	1.68 KG

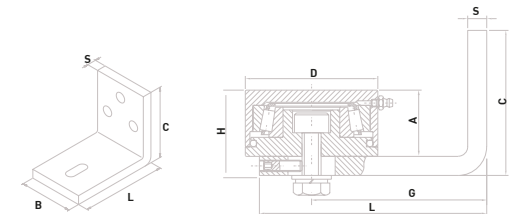

CAV01 / CAV02 / CAV03

GALVANISED STEEL SECURITY CABLE

REFERENCE	mm	No	WEIGHT
CAVO 1	IZ 30 06 00	300	20 6.8
CAVO 2	IZ 50 06 00	300	20 7.7
CAVO 3	IZ 70 06 00	300	20 8.4

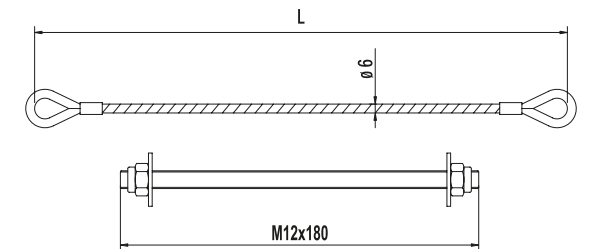

Cantilever Gate Kits

MINI CANTILEVER KIT

UP TO 6M CLEAR OPENING / UP TO 450KG

Cantilever Kit includes:

- 2x CA4RPS 8 Wheeled carriages
- 2x 50B Meeting points
- 2x 41BS Support wheels
- GIPI4RPZ6 Cantilever track

TECHNICAL INFO

GATE MAX WEIGHT	L1	L2	L4	L5	LT	H	E	A	B	C	CARRIAGE STRENGTH
450 KG	3.0	0.9	1.66	0.2	4.7	1.7	0.19	1.8	0.6	0.5	900 KG
450 KG	4.0	1.2	1.96	0.2	6.0	1.7	0.19	2.0	0.6	0.5	900 KG
450 KG	5.0	1.5	2.26	0.2	7.3	1.7	0.19	2.3	0.8	0.5	900 KG
450 KG	6.0	1.8	2.56	0.2	8.6	1.7	0.19	2.6	0.8	0.5	900 KG

REFERENCE	L1 (ml max)	GATE MAX WEIGHT	CANTILEVER TRACK	WEIGHT (kg)
CA4RPS	3 - 6	450	GIPI 4 RP / RPZ	4.79

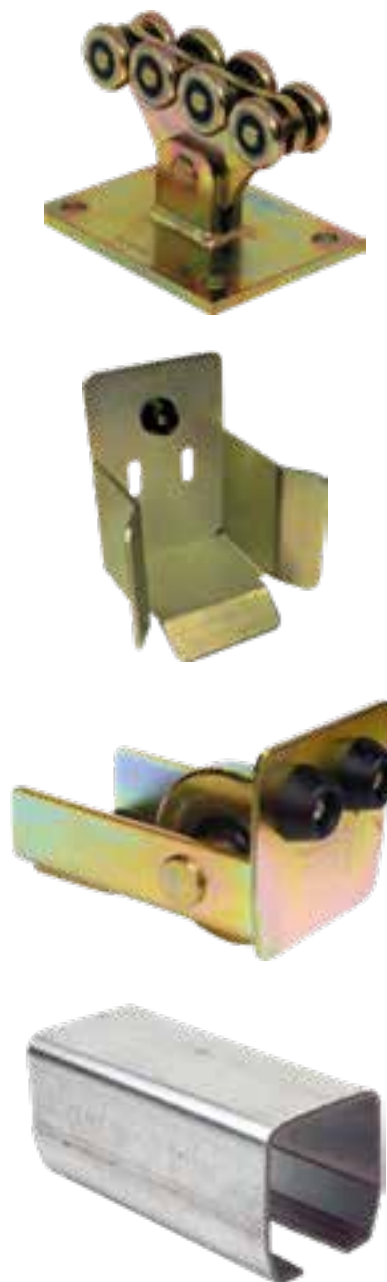
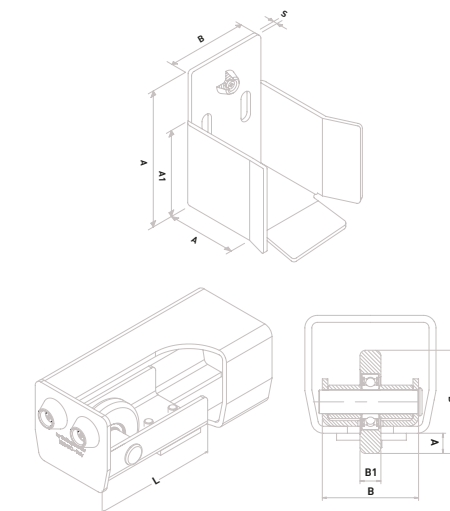
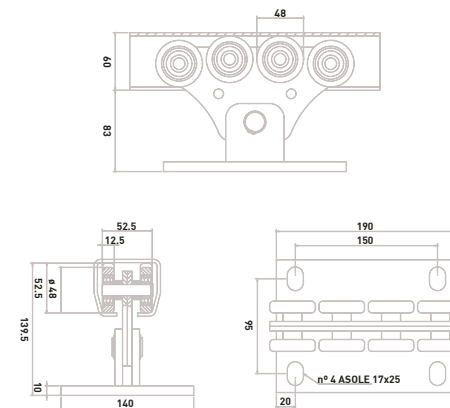
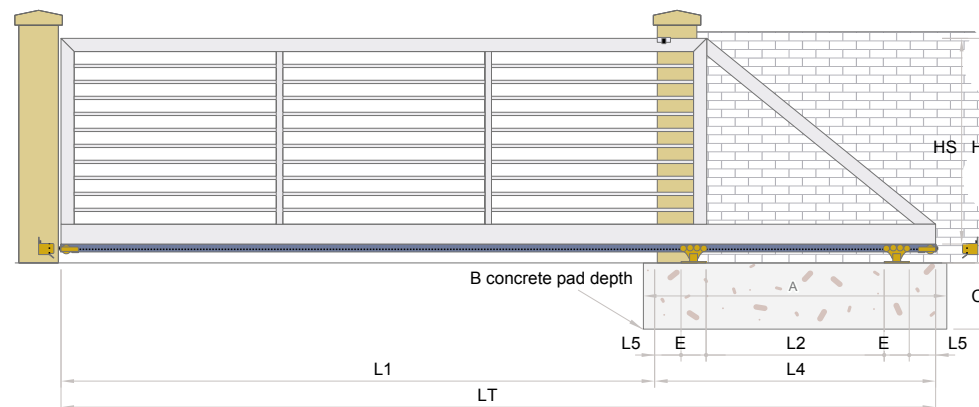

SUPPLIED AS 6M KITS ONLY

ADDITIONAL ACCESSORIES



Cantilever Gate Kits



MEDIUM CANTILEVER KIT

UP TO 8M CLEAR OPENING / UP TO 600KG

Cantilever Kit includes:

- 2x CA4RS 8 Wheeled carriages
- 2x 50P Meeting points
- 2x 41PS Support wheels
- GIPI 5RGZ Cantilever track

GATE MAX WEIGHT	L1	L2	L4	L5	LT	H	E	A	B	C	CARRIAGE STRENGTH
600 KG	4.0	1.2	2.2	0.2	6.2	1.7	0.3	2.5	0.6	0.5	1200 KG
600 KG	5.0	1.5	2.5	0.2	7.5	1.7	0.3	2.8	0.6	0.5	1200 KG
600 KG	6.0	1.8	2.8	0.2	8.8	1.7	0.3	3.2	0.6	0.5	1200 KG
600 KG	7.0	2.1	3.1	0.2	10.1	1.7	0.3	3.7	0.6	0.5	1200 KG
600 KG	8.0	2.4	3.4	0.2	11.4	1.7	0.3	3.7	0.6	0.5	1200 KG

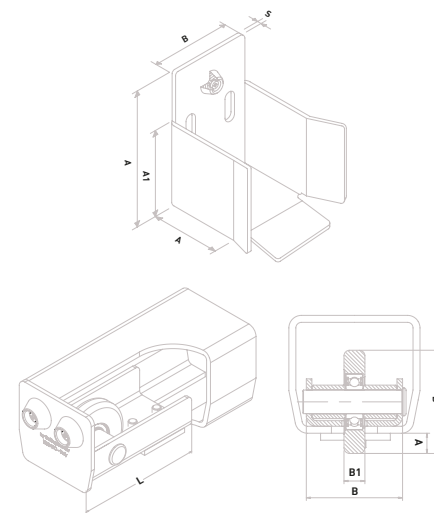
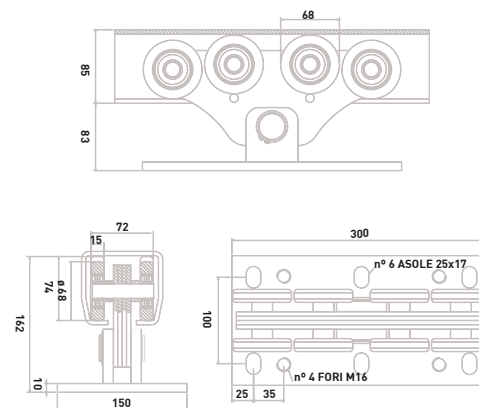
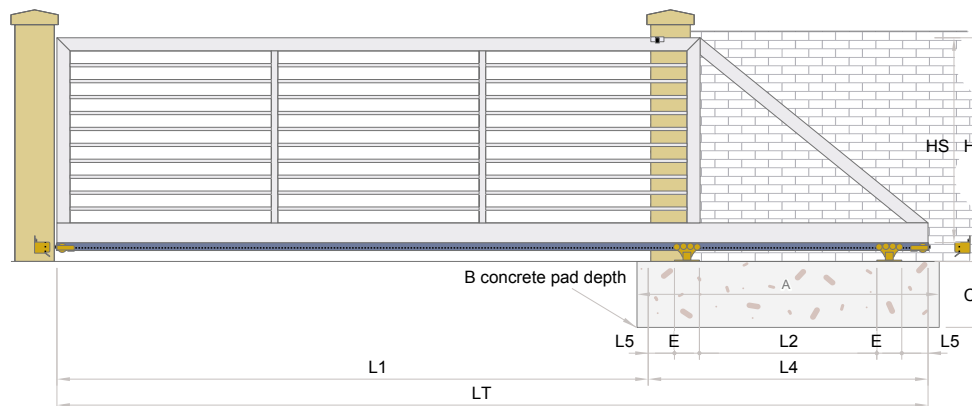

SUPPLIED AS
6M - 10.5M KITS

ADDITIONAL
ACCESSORIES



Cantilever Gate Kits



H900 KITS

UP TO 10M CLEAR OPENING / UP TO 900KG

Cantilever Kit includes:

- 2 x H900-2 Cantilever Carriages
- GIPI5RHZ Galvanised Cantilever Track
- 2 x 41H/SPEC Support Wheels with Cover Plate
- 2 x 50H Meeting Cups

GATE MAX WEIGHT	L1	L2	L4	L5	LT	H	E	A	B	C	CARRIAGE STRENGTH
900 KG	6.0	1.8	2.8	0.2	8.8	1.7	0.3	3.1	0.6	0.5	1800 KG
900 KG	7.0	2.1	3.1	0.2	10.1	1.7	0.3	3.4	0.6	0.5	1800 KG
900 KG	8.0	2.4	3.4	0.2	11.4	1.7	0.3	3.7	0.6	0.5	1800 KG
900 KG	9.0	2.7	3.7	0.2	12.7	1.7	0.3	4.0	0.6	0.5	1800 KG
900 KG	10.0	3.0	4.0	0.2	14.0	1.7	0.3	4.3	0.6	0.5	1800 KG

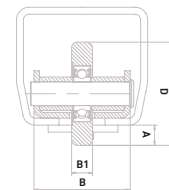
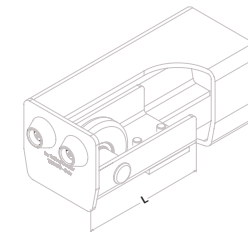
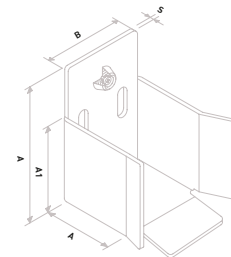
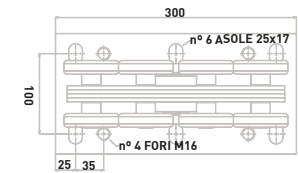
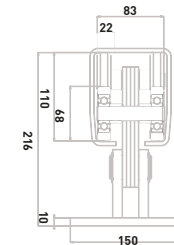
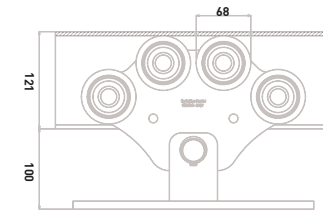
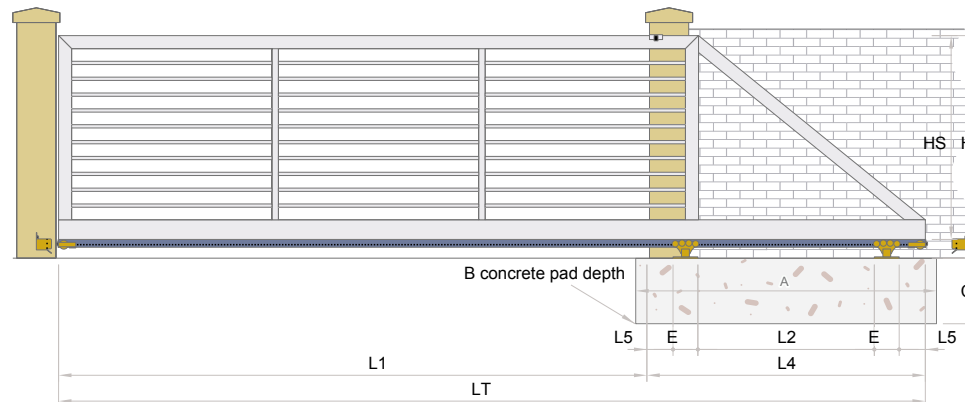

SUPPLIED AS
7M - 15M KITS

ADDITIONAL
ACCESSORIES



Cantilever Gate Kits



MAGNUM CANTILEVER KIT

UP TO 16M CLEAR OPENING / UP TO 1200KG

Cantilever Kit includes:

- 2x CA4 RMS 8 Wheeled carriages
- 2x 50G Meeting points
- 2x 41GS Support wheels
- GIPI6RMZ6 Cantilever track

GATE MAX WEIGHT	L1	L2	L4	L5	LT	H	E	A	B	C	CARRIAGE STRENGTH
1200 KG	9.0	2.7	4.04	0.2	13.0	1.7	0.47	4.2	0.6	0.5	2400 KG
1200 KG	10.0	3.0	4.34	0.2	14.3	1.7	0.47	4.2	0.6	0.5	2400 KG
1200 KG	11.0	3.3	4.64	0.2	15.6	1.7	0.47	4.8	0.8	0.6	2400 KG
1200 KG	12.0	3.6	4.94	0.2	16.9	1.7	0.47	4.8	0.8	0.6	2400 KG
1200 KG	13.0	3.9	5.24	0.2	18.2	1.7	0.47	5.4	0.8	0.6	2400 KG
1200 KG	14.0	4.2	5.54	0.2	19.5	1.7	0.47	5.4	0.8	0.6	2400 KG
1200 KG	15.0	4.5	5.84	0.2	20.8	1.7	0.47	6.0	0.8	0.6	2400 KG
1200 KG	16.0	4.8	6.14	0.2	22.1	1.7	0.47	6.2	0.8	0.6	2400 KG

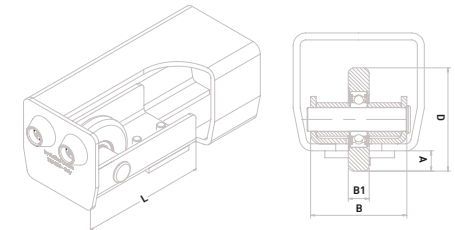
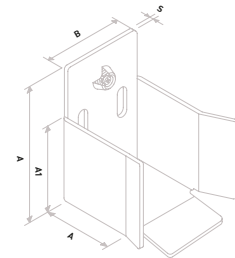
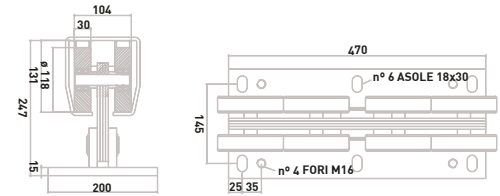
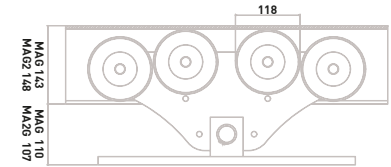
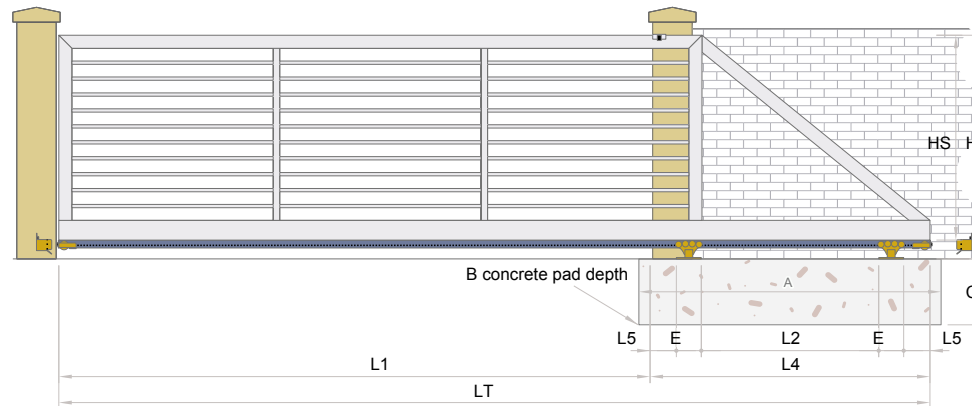

SUPPLIED AS
9M - 18M KITS

ADDITIONAL
ACCESSORIES



Cantilever Gate Kits



MAGNUM2 CANTILEVER KIT

UP TO 18M CLEAR OPENING / UP TO 2200KG

Cantilever Kit includes:

- 2x CA4 RMS2 8 Wheeled carriages
- 2x 50G Meeting points
- 2x 41GS Support wheels
- GIPI 4 RMCZ 6 Cantilever track

GATE MAX WEIGHT	L1	L2	L4	L5	LT	H	E	A	B	C	CARRIAGE STRENGTH
2200 KG	9.0	2.7	4.04	0.2	13.0	1.7	0.47	4.2	0.6	0.5	4400 KG
2200 KG	10.0	3.0	4.34	0.2	14.3	1.7	0.47	4.2	0.6	0.5	4400 KG
2200 KG	11.0	3.3	4.64	0.2	15.6	1.7	0.47	4.8	0.8	0.6	4400 KG
2200 KG	12.0	3.6	4.94	0.2	16.9	1.7	0.47	4.8	0.8	0.6	4400 KG
2200 KG	13.0	3.9	5.24	0.2	18.2	1.7	0.47	5.4	0.8	0.6	4400 KG
2200 KG	14.0	4.2	5.54	0.2	19.5	1.7	0.47	5.6	1.0	0.8	4400 KG
2200 KG	15.0	4.5	5.84	0.2	20.8	1.7	0.47	6.0	1.0	0.8	4400 KG
2200 KG	16.0	4.8	6.14	0.2	22.1	1.7	0.47	6.2	1.0	0.8	4400 KG
2200 KG	17.0	5.1	6.44	0.2	23.4	1.7	0.47	6.5	1.0	0.8	4400 KG
2200 KG	18.0	5.4	6.74	0.2	24.7	1.7	0.47	7.0	1.0	0.8	4400 KG

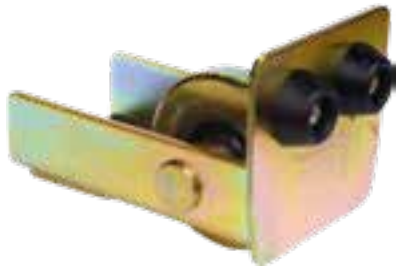
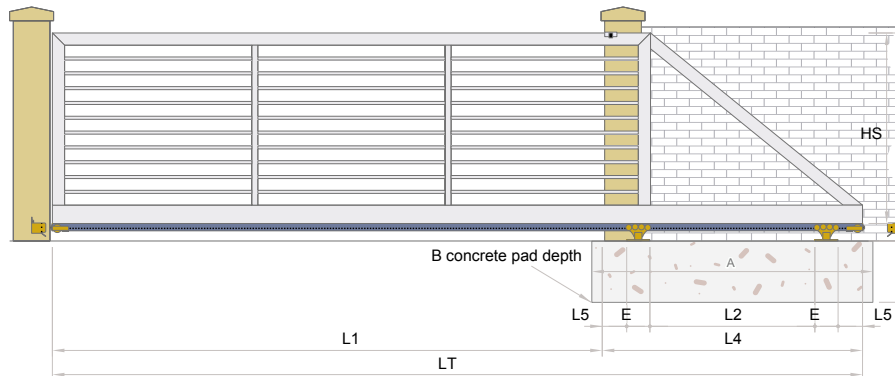
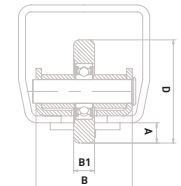
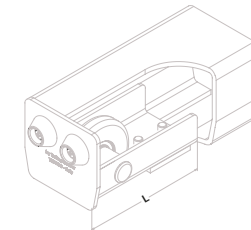
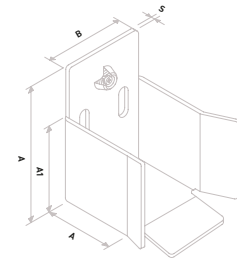
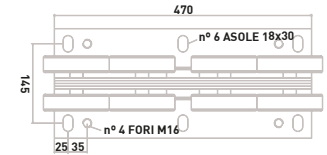
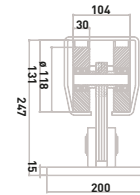
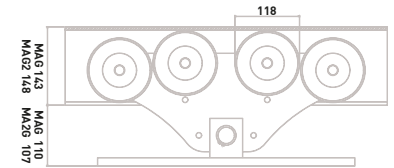

SUPPLIED AS
9M - 24M KITS

ADDITIONAL
ACCESSORIES



Cantilever Accessories



DIMA1

ADJUSTABLE CANTILEVER FIXING PLATE

ARTICLE	REFERENCE	A	E	L	L1	L2	ADJUSTABLE OPENING (l mm)	QTY	WEIGHT
DIMA 1	PZ 30 00 00	470	200	3000	3225	3700	0 ÷ 5000	1	15kg

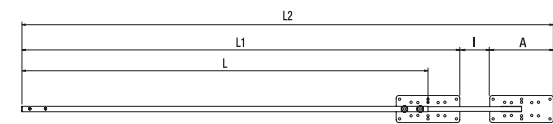

GLOECK / GLOECK40 / GLOECK4060

TENSION ROD

REFERENCE	BOX SECTION	A	B Ø	WEIGHT
GLOECK	60 X 60 X 3	40	54	1.84 KG
GLOECK 40	40 X 40 X 2.5	35	35	1.16 KG
GLOECK 4060	40 X 60 X 2.5	35	35	1.16 KG

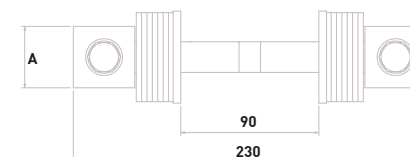
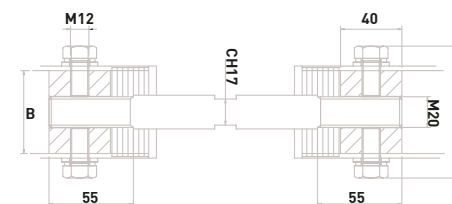

50 R

ADJUSTABLE CANTILEVER SUPPORT ROLLER

REFERENCE	A	B	D	F	H	lxL	S	WEIGHT
50 R	147	60	70	M16	76 ÷ 135	90 x 40 Ø10	6	2 KG

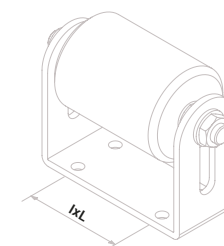

50 RM

CANTILEVER SUPPORT ROLLER

REFERENCE	A	B	D	F	H	lxL	S	WEIGHT
50 RM	220	65	70	Ø20	75	145 x 40 Ø10	8	2.9 KG

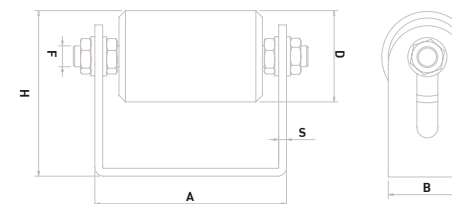

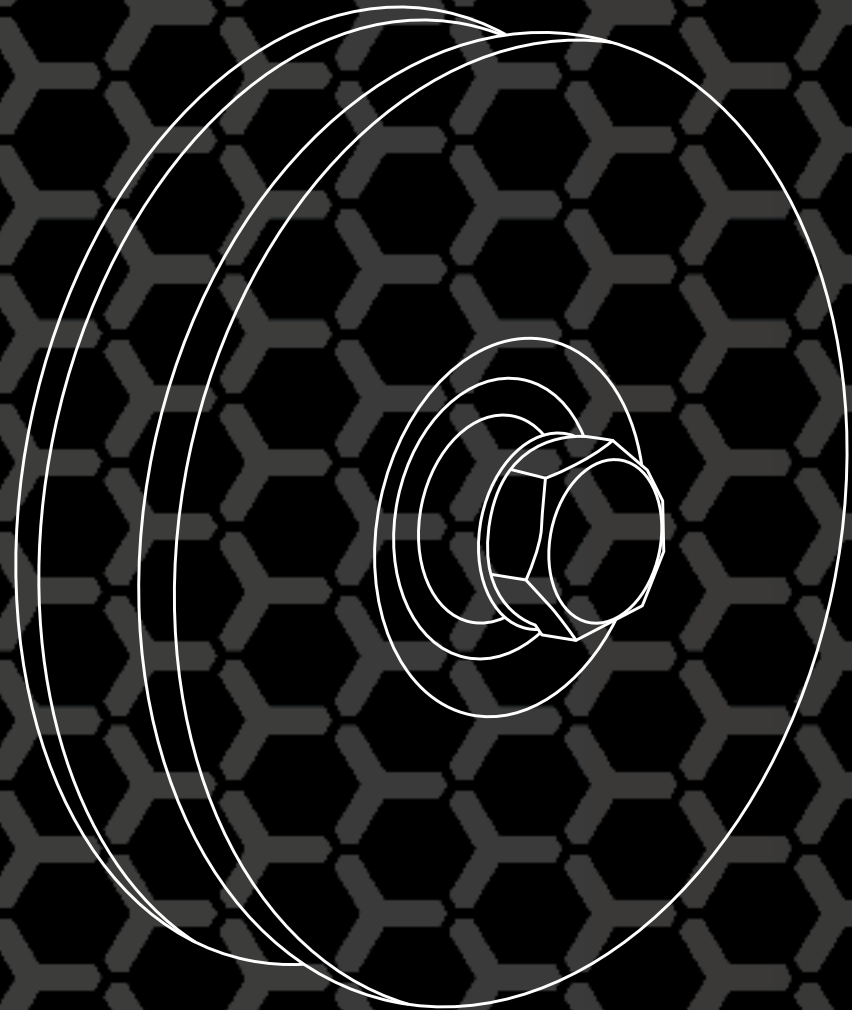
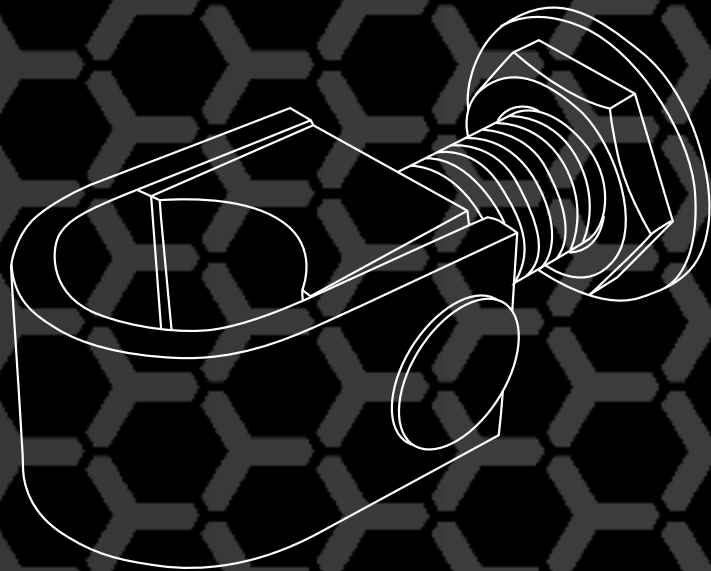

Easygates Direct Ltd

Unit 16, James Scott Road, Halesowen, West Midlands B63 2QT

t: 01384 569 942 | e: info@easygatesdirect.co.uk

RollingCenter^{UK}
INNOVATIVE SOLUTIONS FOR METAL GATES AND DOORS