

L8542094
Rev. 10/07/06

BENINCA®

APRICANCELLO ELETTROMECCANICO
ELECTROMECHANICAL GATE OPENER
ELEKTROMECHANISCHE AUTOMATION FÜR SCHIEBEGITTER
AUTOMATISATION ÉLECTROMÉCANIQUE POUR GRILLES
ABRECANCELA ELECTROMECHANICO
ELEKTROMECHANICZNY OTWIERACZ BRAM

DU.3524L

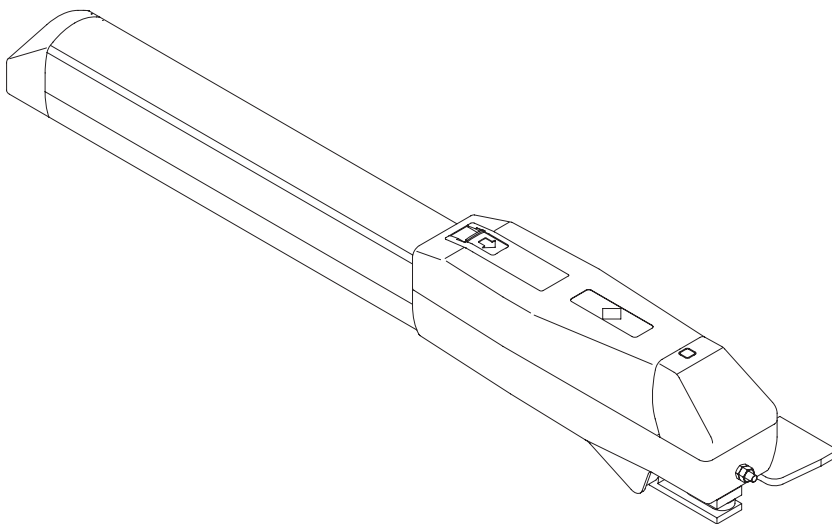

Manual istruzioni e catalogo ricambi

Operating instructions and spare parts catalogue

Betriebsanleitung und Ersatzteilliste

Livret d'instructions et catalogue des pieces de rechange

Manual de instrucciones y catálogo de recambios

Książeczka z instrukcjami i katalog części wymiennych



UNIONE NAZIONALE COSTRUTTORI
AUTOMATISMI PER CANCELLI, PORTE,
SERRANDE ED AFFINI

Dati tecnici	Technical data	Technische Daten	Donnees technique	Datos técnicos	Dane techniczne	DU.3524
Alimentazione	Power supply	<i>Speisung</i>	Alimentation	Alimentación	Zasilanie	24 Vdc
Potenza assorbita	Absorbed rating	<i>Leistung</i>	Puissance absorbée	Potencia absorbida	Natężenie	120 W
Corrente assorbita	Absorbed current	<i>Strom-Verbrauch</i>	Courant absorbé	Corriente absorbida	Pobór mocy	6 A
Spinta	Thrust	<i>Druck</i>	Poussée	Par	Skok	1500 N
Classe isolamento	Insulation class	<i>Isolierklasse</i>	Classe d'isolement	Clase de aislamiento	Klasa izolacji	Y
Temper. funzionamento	Operating temperature	<i>Laufzeit</i>	Température de fonct.	Temperatura funcionam.	Temperatura przy pracy	-20°C / +70°C
Rumorosità	Noise level	<i>Geräuschentwicklung</i>	Bruit	Ruido	Max. hałas	<70 dB
Lubrificazione	Lubrication	<i>Schmierung</i>	Lubrification	Lubrificación	Smarowanie	Molykote Longterm 2 plus
Corsa standard	Standard stroke	<i>Standardhub</i>	Course standard	Carrera estancar	Posuw standard	500 mm
Peso	Weight	<i>Gewicht</i>	Poids	Peso	Ciężar	10 kg

Dimensioni d'ingombro
Overall dimensions
Abmessungen
Dimensions d'encombrement
Dimensiones exteriores
Wymiary gabarytowe

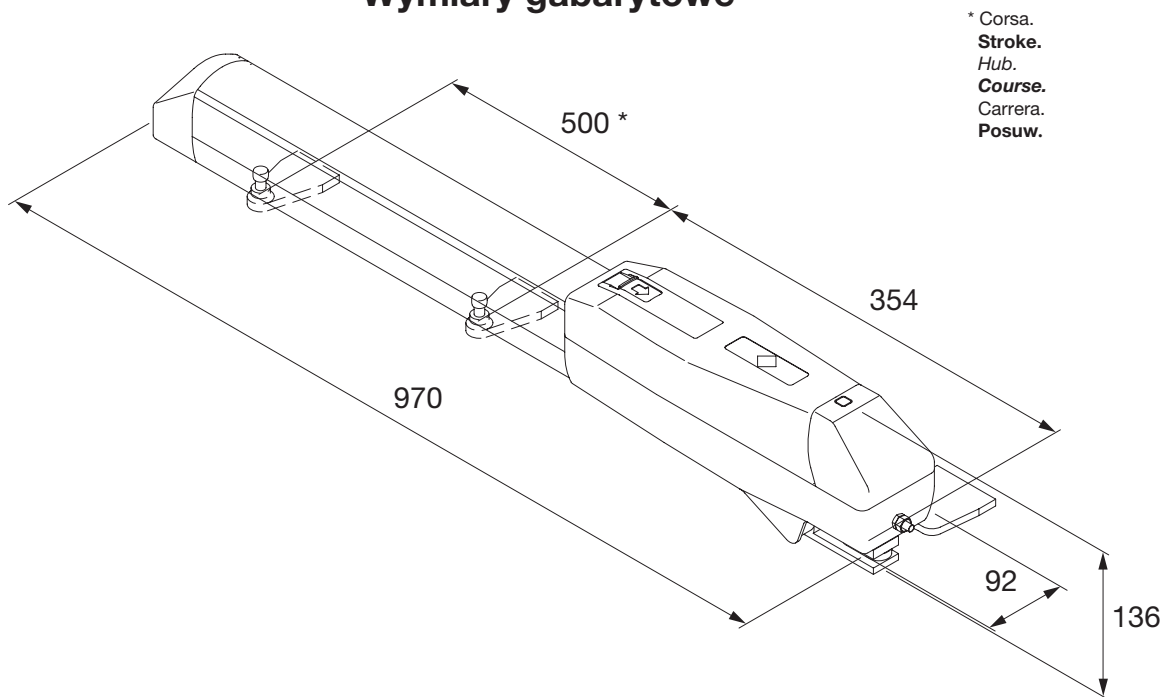

* Corsa.
Stroke.
Hub.
Course.
Carrera.
Posuw.

Arresto in apertura (necessario se non si usa il F. C.).
Stop when opening (necessary if not using the limit stop).
Endanschlag zur Öffnung (nötig, wenn kein Endschalter benutzt wird).
Arrêt en ouverture (arrêt en ouverture nécessaire si on n'utilise pas le F.C.).
 Tope en apertura (necesario si no se usa el F.C.).
Zatrzymanie przy otwieraniu (konieczne, jeżeli nie używa się wyłącznika krańcowego)

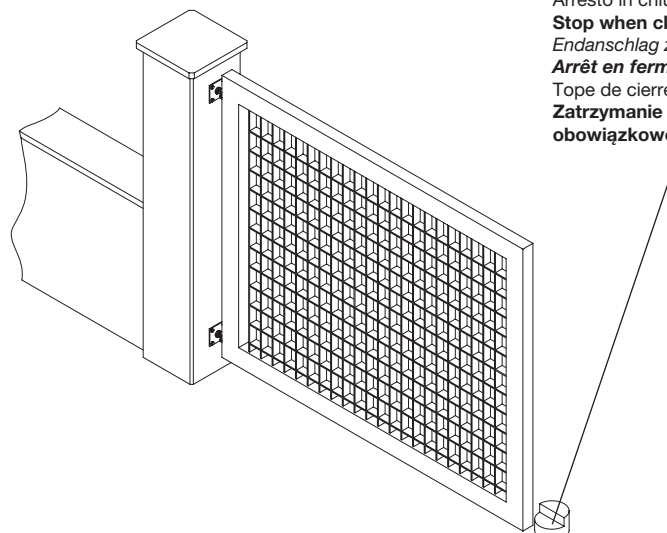

Arresto in chiusura - indispensabile.
Stop when closing - essential.
Endanschlag zur Schließung - unerlässlich.
Arrêt en fermeture - indispensable.
 Tope de cierre indispensable.
Zatrzymanie przy zamykaniu; obowiązkowo.

Fig.1

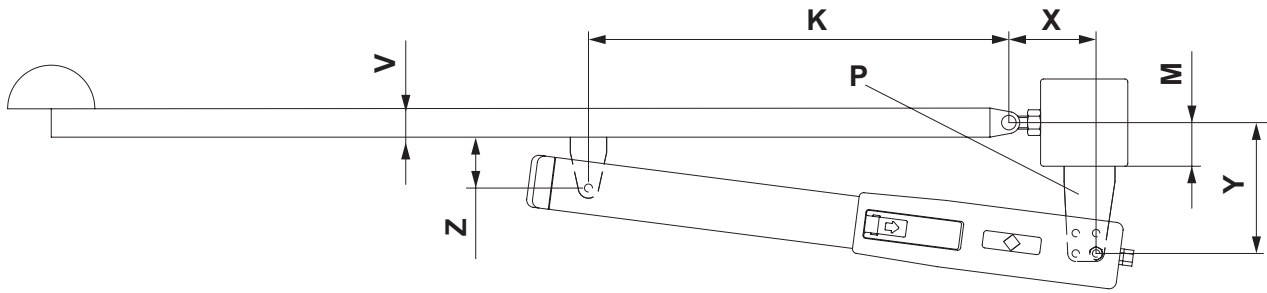

Apertura max. Max. opening Max. Öffnung Ouverture max. Abiertura max. Otwarcie maks.	X	Y	Z min.	K	M* max	Tempo apertura 90° Opening time Öffnungszeit Temps d'ouverture Tiempo de abiertura Czas otwierania	Dimensioni max. anta Max. wing dimensions Max Flügelmasse Dimens. max. de la porte Dimens. max. de la hoja Maks. wymiary skrzydła	
							L (m)	P (kg)
90°	150	150	90	675	90	10" ÷ 21"	2	450
							2,5	350
							3	250
90°	230	230	160	600	155	14" ÷ 32"	4	200
							5	150
130°	150	150	90	675	90	10" ÷ 21"	2	300
							2,5	250
							3	200
							4	150

* N.B.: La quota M max. è riferita ad una quota V= 50 mm
 * **N.B.: The dimension M max. refers to a dimension V= 50 mm**
 * N.B.: Das Maß M max. bezieht sich auf ein Maß V= 50 mm
 * **N.B.: La cote M max. est référée à une cote V= 50 mm**
 * N.B.: La cota M máx. hace referencia a la cota V= 50 mm
 * **N.B.: Wymiar M max odnosi się do parametru V = 50 mm**

Fig.2

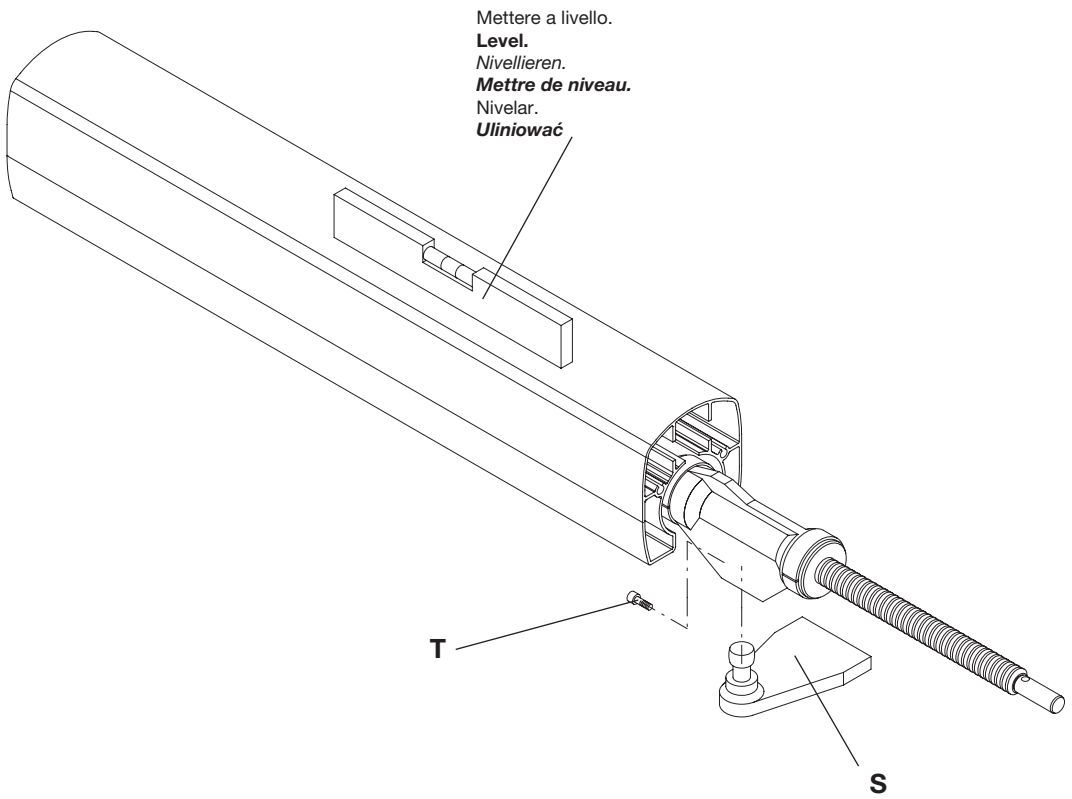

Vite Ø3.9 UNI 6955.
Screw Ø3.9 UNI 6955.
 Schraube Ø3.9 UNI 6955.
Vis Ø3.9 UNI 6955.
 Tornillo Ø3.9 UNI 6955
Sruba Ø3.9 UNI 6955.

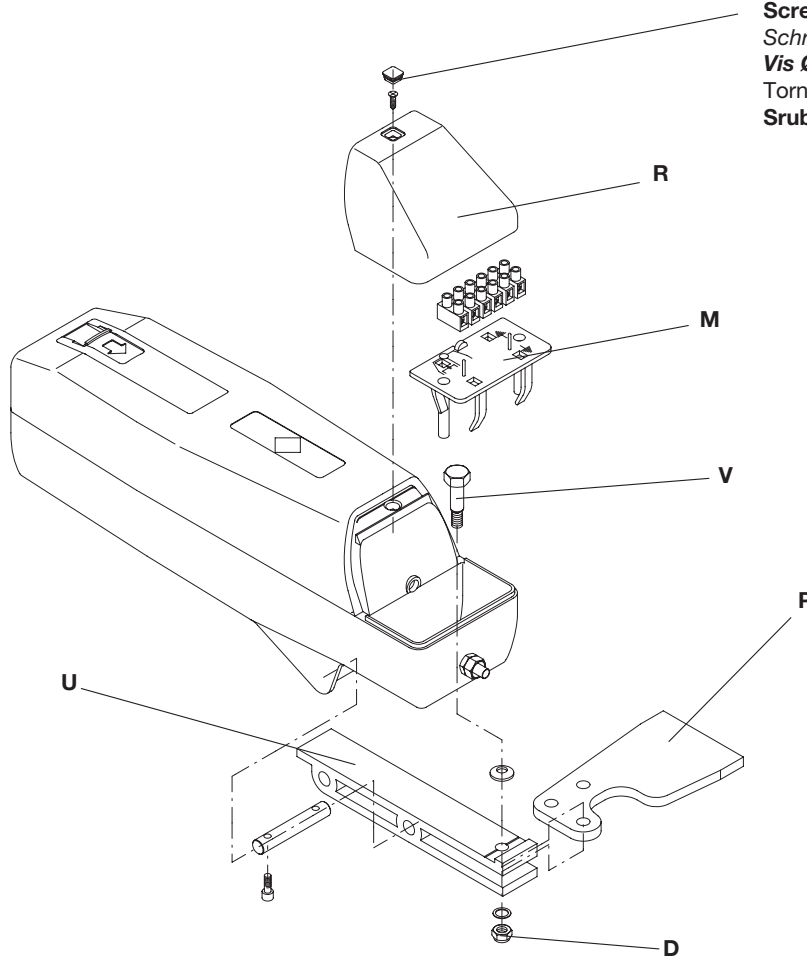
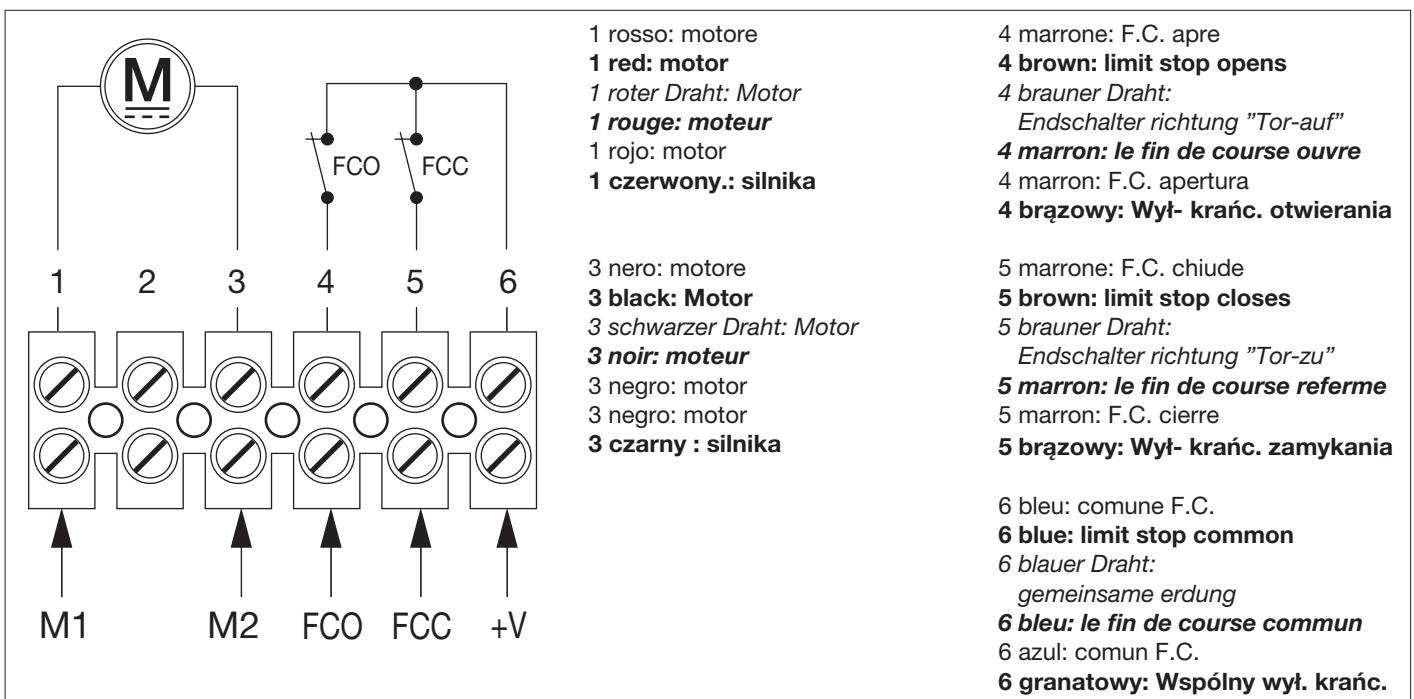

Fig.3

Collegamenti - **Connections** - Kabelanschlüsse
Connexions - Conexiones - **Połączenia**



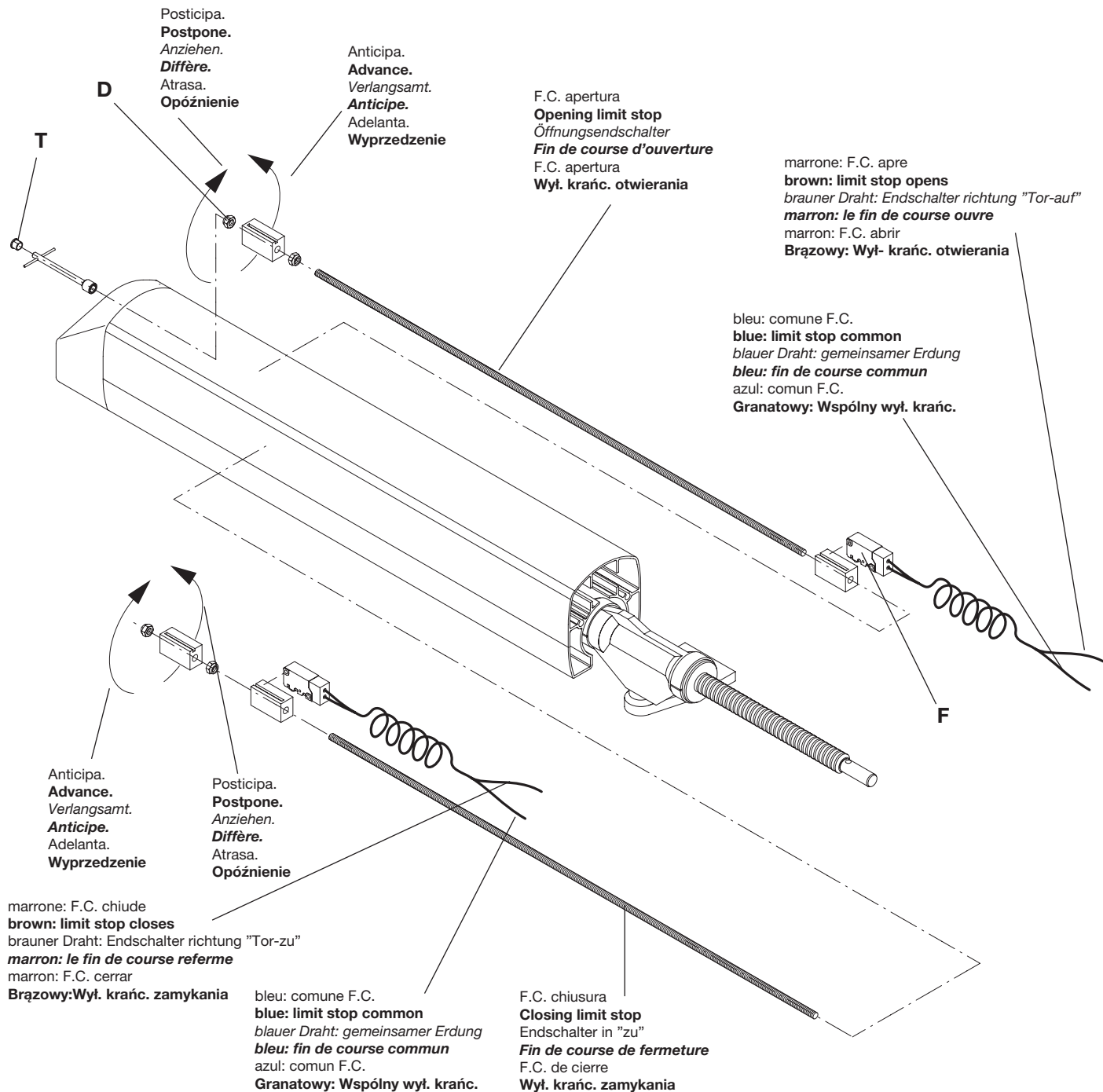
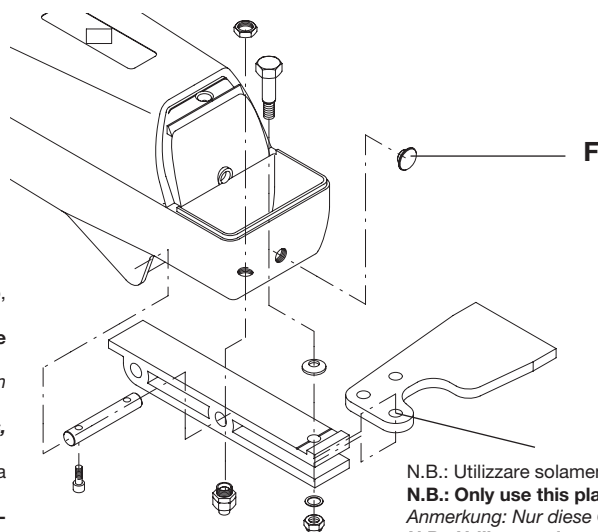

Fig.4



Attenzione: se l'automatismo non viene fermato in tempo, la piastra può tranciare il cavo.

Warning: if the automatism does not stop in time, the plate may cut the cable.

Achtung: Wenn der Antrieb nicht rechtzeitig angehalten wird, kann die Platte das Kabel durchschneiden.

Attention: si l'automatisme n'est pas arrêté à temps, la plaque peut couper le câble.

Atencion! Si el automatismo no se para a tiempo, la pletina de anclaje puede cortar la manguera.

Uwaga: jeżeli urządzenie automatyzacji nie zostanie odpowiednio wcześniej zatrzymane, płyta może przeciąć przewód.

N.B.: Utilizzare solamente questo foro della piastra.

N.B.: Only use this plate hole.

Anmerkung: Nur diese Öffnung der Platte verwenden.

N.B.: Utiliser seulement ce trou de la plaque.

NOTA: Utilizar solamente este agujero de la pletina de anclaje.

N.B.: Należy używać wyłącznie tego otworu płyty.

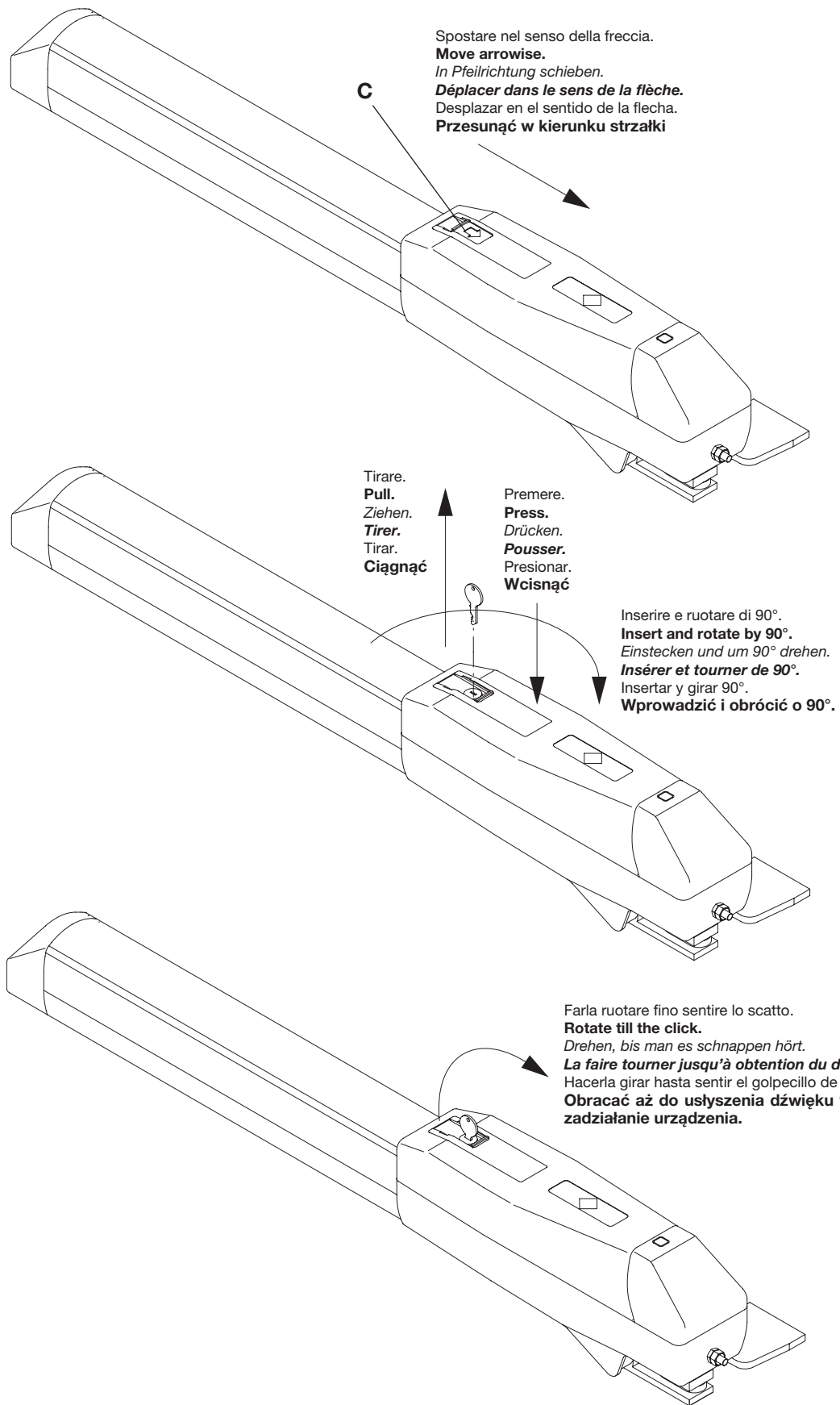
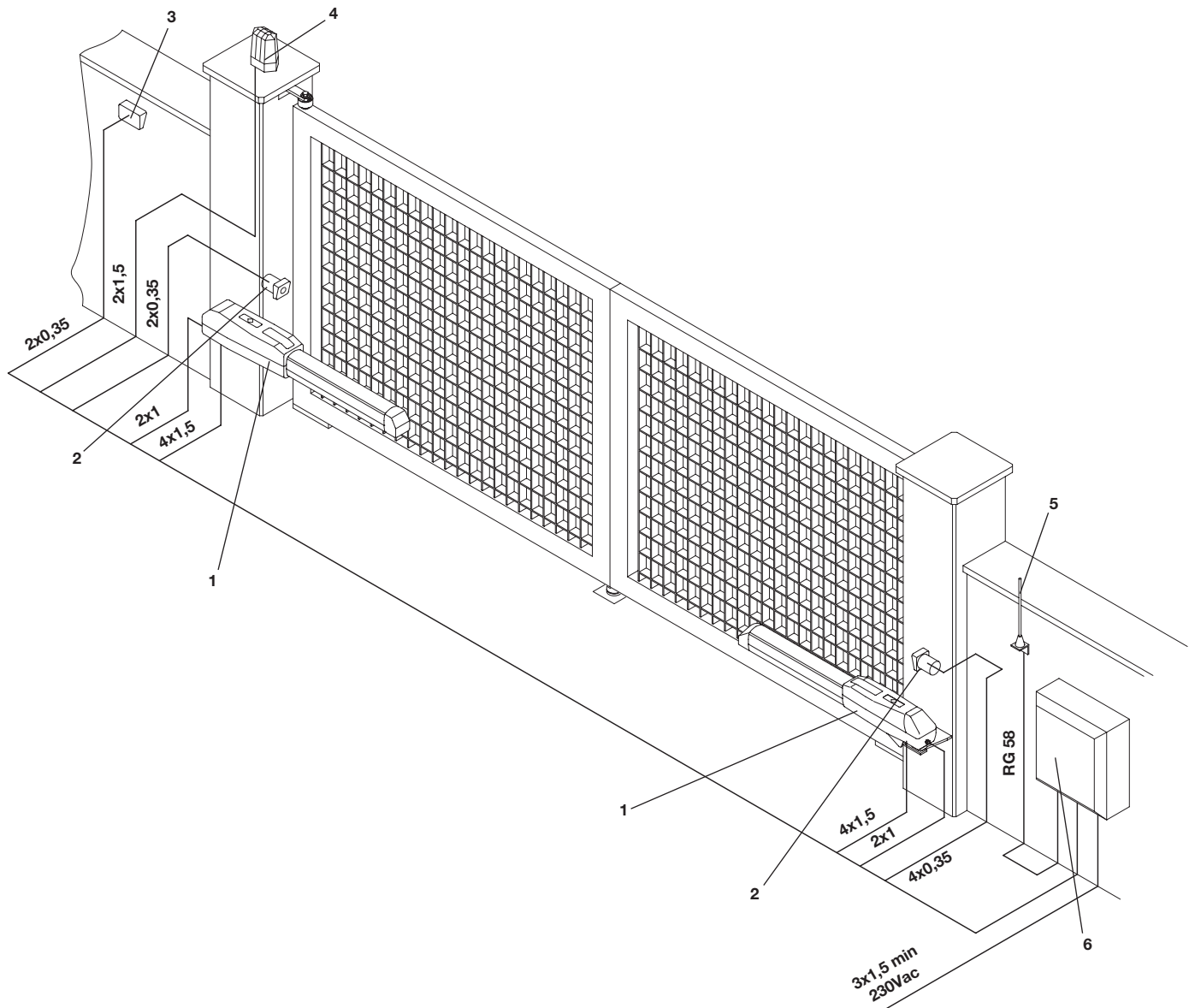

Fig.5



Legenda:

- 1 Motoriduttore DU.3524L
- 2 Fotocele SC.P50 (da incasso), SC.P50E (da esterno)
- 3 Selettore a chiave ID.SC o ID.SCE (da esterno) o tastiera digitale ID.PTD
- 4 Lampeggiante ID.LUX24
- 5 Antenna LO.E1N o LO.E1LUX (quarzata)
- 6 Centrale elettronica DA.24A

Legenda:

- 1 Motoreducer DU.3524L
- 2 Photo-electric cells SC.P50 (built in) or SC.P50E (external)
- 3 Key selector ID.SC or ID.SCE (external) or digital keyboard ID.PTD
- 4 Flash-light ID.LUX24
- 5 Antenna LO.E1N or LO.E1LUX (quartz)
- 6 Electronic gearcase DA.24A

Zeichenerklärung:

- 1 Getriebemotor DU.3524L
- 2 Fotozelle SC.P50 (eingelegt), SC.P50E (außenliegend)
- 3 Schlüssel-Selektor ID.SC oder ID.SCE (außenliegend) oder Digital-Tastatur ID.PTD
- 4 Blinker ID.LUX24
- 5 Antenne LO.E1N oder LO.E1LUX (Quartz)
- 6 Elektroschrank DA.24A

Légende:

- 1 Moteur-réducteur DU.3524L
- 2 Photocellule SC.P50 (noyée) - SC.P50E (d'extérieur)
- 3 Selecteur à clé ID.SC ou ID.SCE (d'extérieur) ou clavier digital ID.PTD
- 4 Clignotant ID.LUX24
- 5 Antenne LO.E1N ou LO.E1LUX (au quartz)
- 6 Centrale électronique DA.24A

Legenda:

- 1 Motorreductor DU.3524L
- 2 Fotocélulas SC.P50 (de empotrar), SC.P50E (de superficie).
- 3 Selectores a llave ID.SC o ID.SCE (de superficie).
- 4 Relampagueador ID.LUX24
- 5 Antena LO.E1N o LO.E1LUX (cuarzada).
- 6 Central electrónica DA.24A.

Legenda:

- 1 Siłownik DU.3524L
- 2 Fotokomórki SC.P50 (wbudowane), SC.P50E (zewnątrzne)
- 3 Wyłącznik kluczowy ID.SC lub ID.SCE (zewnątrzny) lub elektroniczna tablica przyciskowa ID.PTD
- 4 Lampa migocząca ID.LUX24
- 5 Antena LO.E1N (superczuła) lub LO.E1LUX (kwarcowa)
- 6 Centrala elektroniczna DA.24A

N.B.: Tenere separati i cavi di potenza da quelli ausiliari.

N.B.: The power cables must be kept separated from the auxiliary cables.

Wichtig: Leistungskabel von Hilfskabeln getrennt halten.

N.B.: Séparer les câbles de puissance des câbles auxiliaires.

N.B.: Tener separados los cables de potencia de los auxiliares.

Uwaga: należy trzymać w oddali przewody zasilania od przewodów pomocniczych.

Introduction

Thank you for choosing our DU.3524L ratiomotor.

All items in the wide Benincà production range are the result of twenty-years' experience in the automatism sector and of continuous research for new materials and advanced technologies.

We are, therefore, in the position to offer highly reliable products that due to their power, effectiveness and useful life, fully satisfy the final user's requirements.

All our products are manufactured to the existing standard and are covered by warranty.

Possible injury to people or accidents caused by defects in construction are covered by a civil liability policy drawn up with one of the major insurance companies.

General information

For an efficient operation of these automatisms, the gate must have the following features:

- good stoutness and stiffness
- all hinges must have positive clearances and permit smooth and regular manual operations.
- when wings are closed their height have to fit together.

1. General features

The DU.3524L electromechanical gate opener is simple and reliable and can be installed onto any swing-gate having up to 5m max wings. Harmonious and elegant it is made entirely in aluminium.

The stout and well tested reduction unit makes it reliable and noiseless. It is also equipped with simple and easily adjustable limit stops and an emergency release with personalised key. Suitable for heavy duty. Battery-powered on request.

2. Mechanical stops (fig. 1)

It is necessary that the gate to be automatised has got a mechanical stop when closing; this mechanical stop becomes necessary also when opening in case the suitable limit stop is not used.

3. Automatism positioning

3.1 Fix the distance from the ground of the automatism has (it is advisable it is in the middle of the gate and possibly close to a strong ledger). Now weld the plate P (if the pilaster is made of cement ask for the screwing flask) as per dimensions given on fig. 2).

3.2 When the gate is closing, weld the flask S at the same level of the plate P (fig. 3) to a gate ledger or to another stout element; please remember that in this condition the piston must not be totally at the end of its stroke.

- Remove then the protection R and the terminal board support M.
- Insert the back articulated joint U onto the plate P and insert the pivot V. Tighten the pivot through the self-blocking nut D.
- Tighten now the screw T.

Note

The power supply cable can be introduced into the lower part of the automatism, by means of one of the two holes situated there. If this is the case, use the plate hole indicated in the figure and make sure that the automatism stops before cutting the cable.

4. Limit stop adjustment (fig.4)

For the limit stop adjustment when opening, proceed as follows:

- remove cap T
- loosen nut D by means of a 10mm hexagon head socket spanner; turn the nut clockwise to advance the triggering of the limit switch F and anticlockwise to postpone triggering.

5. Release and manual move

As all the other automatisms in the Benincà production range, also the DU.3524L has a simple and functional release which permits the manual move when there is no electricity. To release the automatism, please proceed as follows (see fig. 5):

- Move the lock-cover C until the arrow is visible.
- Insert the personalised key and rotate it by 90°.
- Press onto the back side of the door P and rotate it to a click by pulling from the front side.

In order to make it run again, lower the small door; the first manoeuvre will re-establish the manual operation.

P.N.: if the opening limit stop is not used, it is advisable to bring the gate in a position close to the closing one before re-establishing the automatic running.

CAUTION

The civil liability policy, which covers possible injuries to people or accidents caused by defects in construction, requires the system to be to existing standard and to use original Benincà accessories.

DU.3524L

Libro istruzioni per l'utente - User's handbook
Handbuch für den Verbraucher - Manuel d'instructions pour l'utilisateur
Manual de instrucciones para el usuario - Książeczka z instrukcjami dla użytkownika

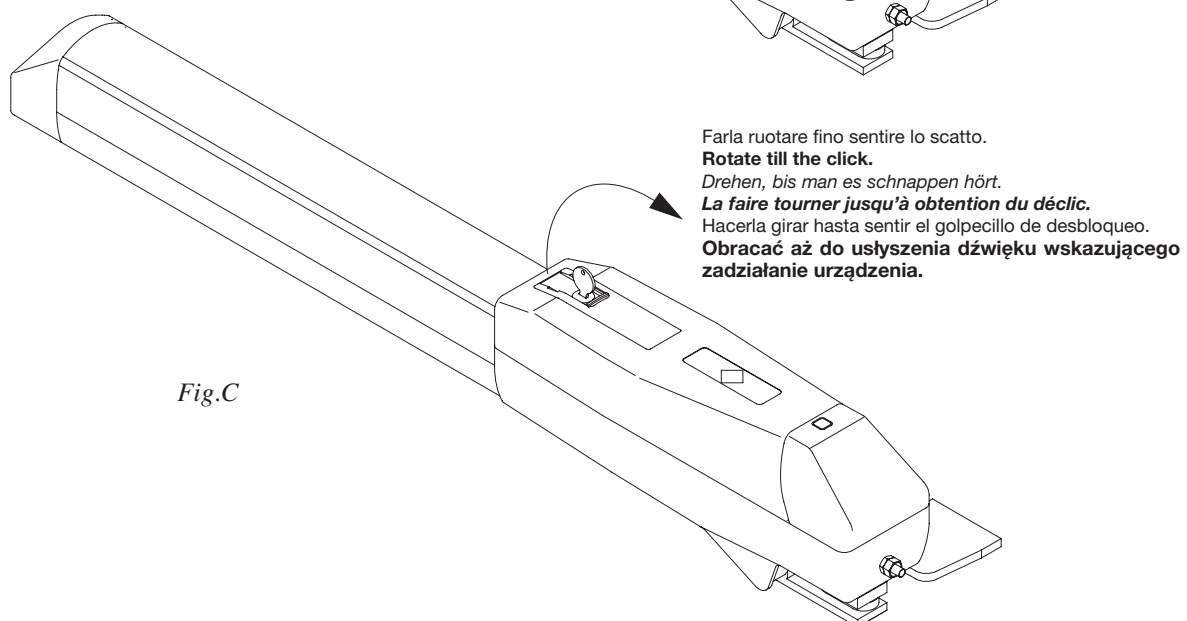
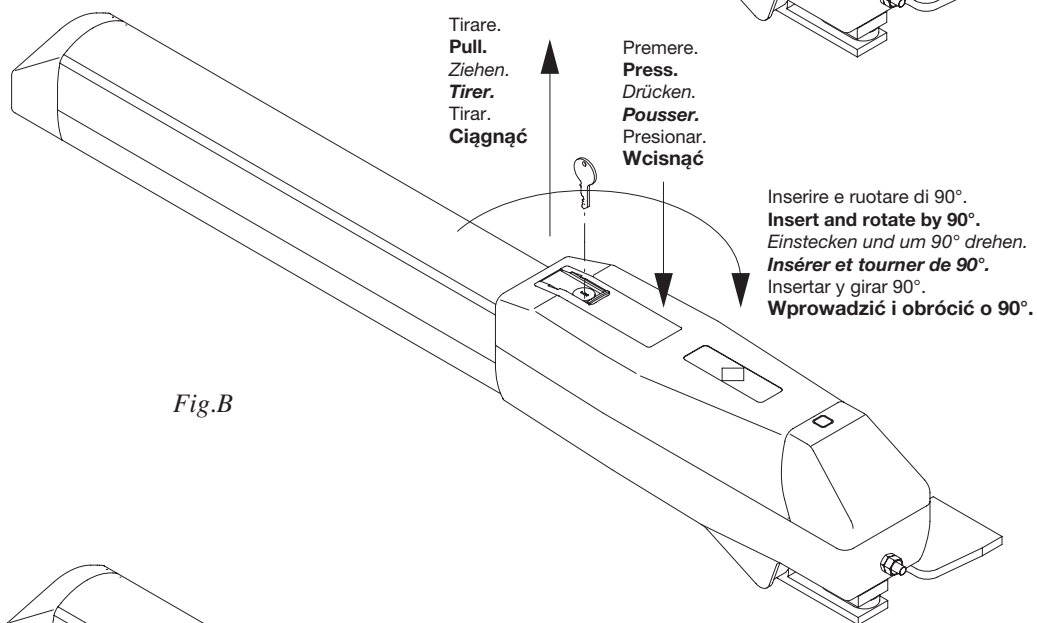
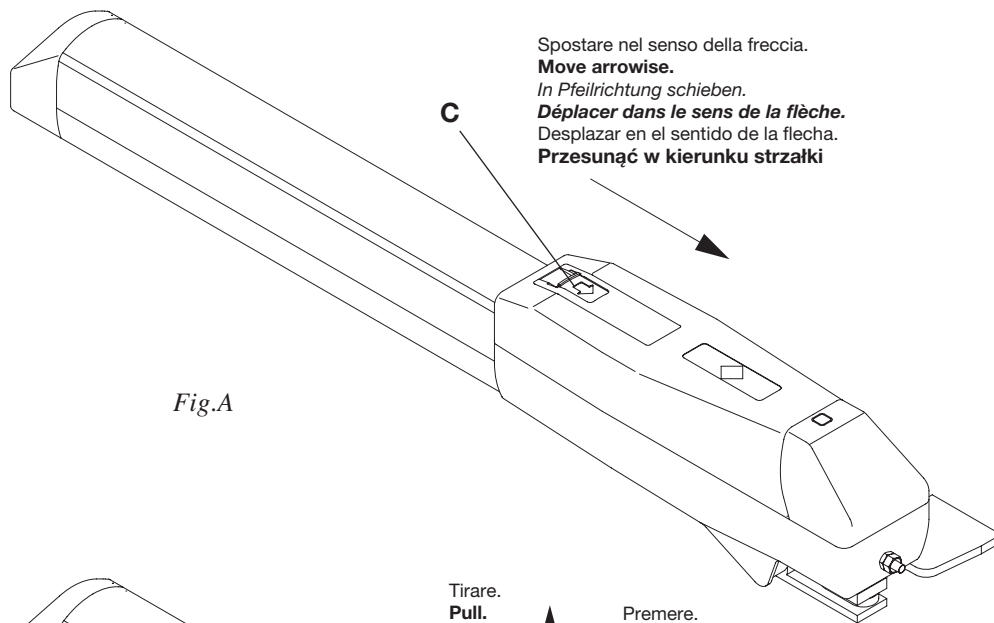

Norme di sicurezza

- Non sostare nella zona di movimento delle ante.
- Non lasciare che i bambini giochino con i comandi o in prossimità delle ante.
- In caso di anomalie di funzionamento non tentare di riparare il guasto ma avvertire un tecnico specializzato.

Manovra manuale e d'emergenza

In caso di mancanza dell'energia elettrica o di guasto, per azionare manualmente le ante procedere come segue (riferirsi alle figure A,B,C):

- spostare il copriserratura C nel senso della freccia fino a vedere quest'ultima.
- Inserire la chiave personalizzata e ruotarla di 90°.
- Premere sul lato posteriore della portina P ed, aiutandosi poi tirandola dalla parte anteriore, farla ruotare fino a sentire lo scatto.

Per ripristinare il funzionamento abbassare la portina; la prima manovra ripristinerà il normale funzionamento.

N.B.: Se non si utilizza il finecorsa in apertura, è consigliabile portare il cancello in posizione prossima alla chiusura prima di ripristinare il funzionamento automatico.

Manutenzione

- Controllare periodicamente l'efficienza dello sblocco manuale di emergenza.
- Astenersi assolutamente dal tentativo di effettuare riparazioni, potreste incorrere in incidenti; per queste operazioni contattare un tecnico specializzato.
- L'attuatore non richiede manutenzioni ordinarie, tuttavia è necessario verificare periodicamente l'efficienza dei dispositivi di sicurezza e le altre parti dell'impianto che potrebbero creare pericoli in seguito ad usura.

Smaltimento

Qualora il prodotto venga posto fuori servizio, è necessario seguire le disposizioni legislative in vigore al momento per quanto riguarda lo smaltimento differenziato ed il riciclaggio dei vari componenti (metalli, plastiche, cavi elettrici, ecc.); è consigliabile contattare il vostro installatore o una ditta specializzata ed abilitata allo scopo.

Attenzione

Tutti i prodotti Benincà sono coperti da polizza assicurativa che risponde di eventuali danni a cose o persone causati da difetti di fabbricazione, richiede però la marcatura CE della "macchina" e l'utilizzo di componenti originali Benincà.

Safety rules

- *Do not stand in the movement area of the gate.*
- *Do not let children play with controls and near the gate.*
- *Should operating faults occur, do not attempt to repair the fault but call a qualified technician.*

Manual and emergency manoeuvre

In the event of a power cut or breakdown, proceed as follows to operate the wings manually (refer to figures A,B,C):

- *Move the lock-cover C until the arrow is visible.*
- *Insert the personalised key and rotate it by 90°.*
- *Press onto the back side of the door P and rotate it to a click by pulling from the front side.*

In order to make it run again, lower the small door; the first manoeuvre will re-establish the manual operation.

P.N.: if the opening limit stop is not used, it is advisable to bring the gate in a position close to the closing one before re-establishing the automatic running.

Maintenance

- *Every month check the good operation of the emergency manual release.*
- *It is mandatory not to carry out extraordinary maintenance or*

repairs as accidents may be caused. These operations must be carried out by qualified personnel only.

- *The operator is maintenance free but it is necessary to check periodically if the safety devices and the other components of the automation system work properly. Wear and tear of some components could cause dangers.*

Waste disposal

If the product must be dismantled, it must be disposed according to regulations in force regarding the differentiated waste disposal and the recycling of components (metals, plastics, electric cables, etc.). For this operation it is advisable to call your installer or a specialised company.

Warning

All Benincà products are covered by insurance policy for any possible damages to objects and persons caused by construction faults under condition that the entire system be marked CE and only Benincà parts be used.

Sicherheitsvorschriften

- Nicht im Öffnungsbereich verweilen.
- Kinder nicht mit den Steuerungen oder in der Nähe des Tores spielen lassen.
- Bei Funktionsausfällen nicht versuchen, den Schaden selber zu beheben, sondern den Techniker rufen.

Manuelle Bedienung und Notbetrieb

Um das Tor im Falle eines Stromausfalls oder einer Betriebsstörung von Hand betätigen zu können, die Entriegelung wie folgt einsetzen (siehe Abbildungen A, B, C):

- Schloßdeckel C in Pfeilrichtung schieben, bis der Pfeil sichtbar wird.
- Den individuellen Schlüssel einstecken und um 90° drehen.
- Auf die Rückseite des Türchens P drücken, dieses nach vorn ziehen und drehen, bis man es schnappen hört.

Zur Wiederaufnahme des Betriebes das Türchen senken. Die erste Verschiebung stellt den normalen Betrieb wieder her. Anmerkung: benutzt man den Endschalter nicht beim Öffnen, sollte man das Tor nahezu in Schließstellung bringen, bevor man den automatischen Betrieb wiederherstellt.

Wartung

- Monatliche Kontrolle der manuellen Notentriegelung
- Es ist absolut untersagt, selbstständig Sonderwartung oder Reparaturen vorzunehmen, da Unfälle die Folge sein können; wenden Sie sich an den Techniker.
- Der Antrieb braucht keine ordentliche Unterhaltung aber es ist periodisch notwendig die Leistungsfähigkeit der Sicherheitsvorrichtungen und die andere Teile des Anlages zu prüfen. Sie könnten durch Abnutzung Gefahr hervorbringen.

Entsorgung

Wird das Gerät außer Betrieb gesetzt, müssen die gültigen Gesetzesvorschriften zur differenzierten Entsorgung und Wiederverwendung der Einzelkomponenten, wie Metall, Plastik, Elektrokabel, usw., beachtet werden. Rufen Sie Ihren Installateur oder eine Entsorgungsfirma.

Achtung

Alle Produkte BENINCA' wurden mit einem Versicherungsschein versehen, der alle eventuellen Schäden an Dingen oder Personen abdeckt, die durch Herstellungsdefekte hervorgerufen wurden, vorausgesetzt, das Gerät besitzt die Kennzeichnung EU und es wurden original BENINCA' Einzelkomponenten verwendet.

Normes de sécurité

- *Ne vous arrêtez jamais dans la zone de mouvement des portes.*
- *Ne laissez pas les enfants jouer avec les commandes ou à proximité des portes.*
- *En cas d'anomalies de fonctionnement, n'essayez pas de réparer*

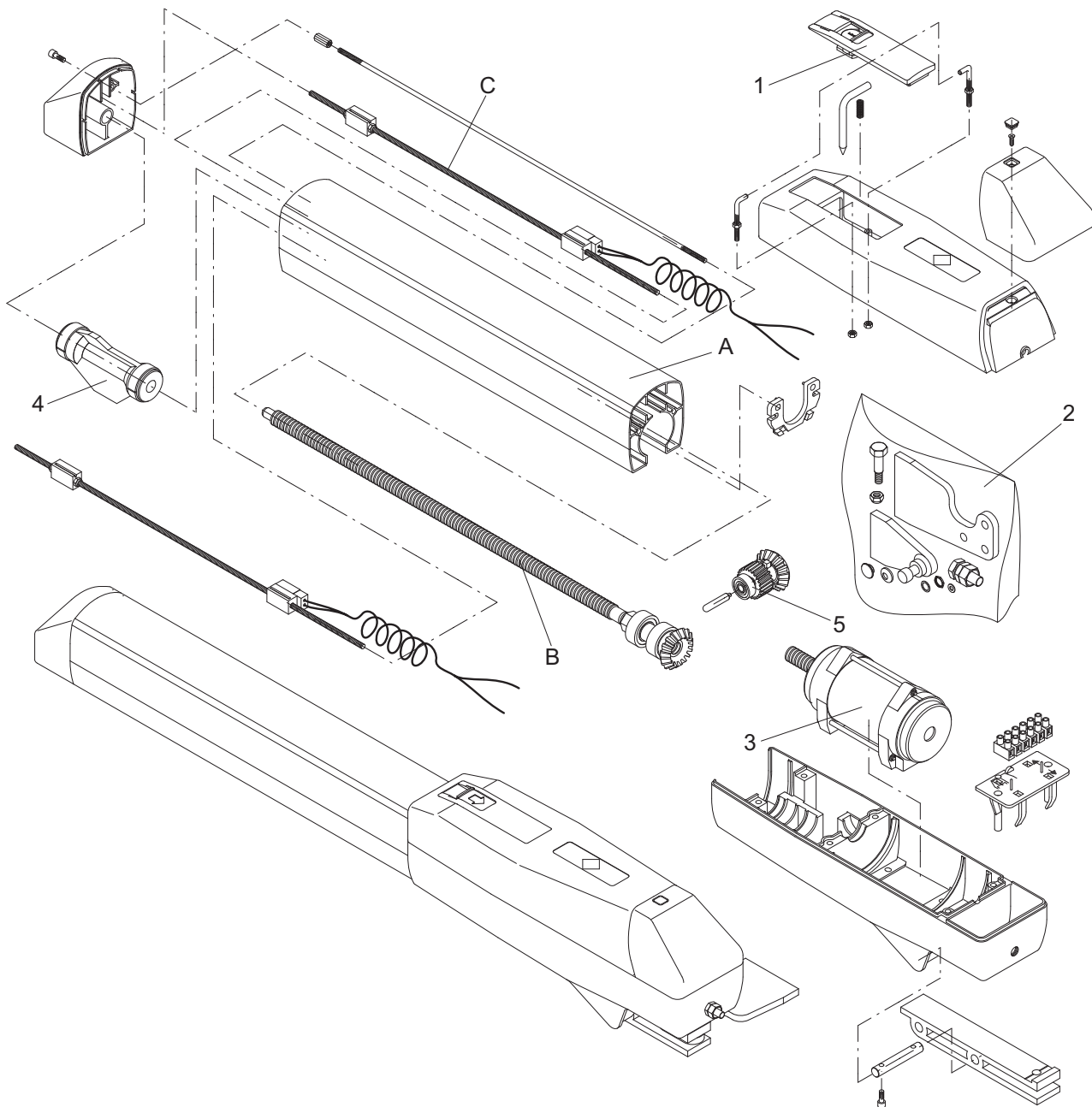

Pos.	Denominazione - Description - Bezeichnung - Dénomination - Denominación - Określenie						Cod.
A	Tubo alluminio	Guide	Führung	Guide	Guía aluminio	Rura	9686148
B	Vite senza fine	Screw	Schraube	Vis sans fin	Tornillo sin fin	Śruba dwustronna	9686149
C	Coppia finecorsa	Limit stop	Endschalter	Fin de course	Final de carrera	Krańcówka	9686081
1	Leva di sblocco	Release lever	Hebel	Levier	Pal. de desbloq.	Dźwignienka	9686054
2	Blister	Blister	Blister	Blister	Blister	Blister	9686078
3	Motore	Motor	Motor	Moteur	Motor	Silnik	9686079
4	Supporto	Support	Stütze	Support	Soporte	Zaczepek	9686052
5	Ingranaggio	Release gear	Zahnrad	Engrenage	Engranaje	Koło zębate	9686051

BENINCA®