

L8542624
Rev. 04/03/02

BENINCA®

CENTRALINA A MICROPROCESSORE PER
CONTROL UNIT WITH MICROCONTROLLER FOR
MIKROCONTROLLER-STEUERUNG FÜR
CENTRALE A MICROCONTRÔLEUR POUR
CENTRALITA A MICROPROCESADOR POR

RI.15KI

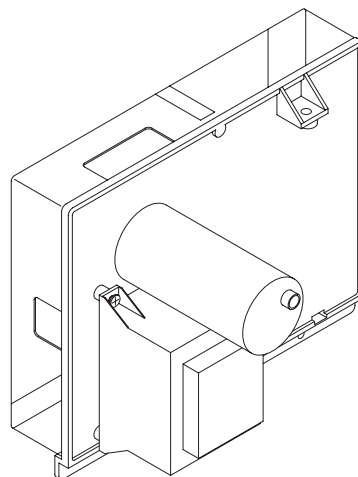

Libro istruzioni
Operating instructions
Betriebsanleitung
Livret d'instructions
Libro de instrucciones

UNIONE NAZIONALE COSTRUTTORI
AUTOMATISMI PER CANCELLI, PORTE,
SERRANDE ED AFFINI

Dichiarazione CE di conformità
EC declaration of conformity
EG-Konformitätserklärung

Déclaration CE de conformité
Declaracion CE de conformidad

Con la presente dichiariamo che il nostro prodotto
We hereby declare that our product
Hiermit erklären wir, dass unser Produkt
Nous déclarons par la présente que notre produit
Por la presente declaramos que nuestro producto

RI.15KI

è conforme alle seguenti disposizioni pertinenti:
complies with the following relevant provisions:
folgenden einschlagigen Bestimmungen entspricht:
correspond aux dispositions pertinentes suivantes:
satisface las disposiciones pertinentes siguientes:

Direttiva sulla compatibilità elettromagnetica (89/336/
CCE, 93/68/CEE)
EMC guidelines (89/336/EEC, 93/68/EEC)
EMV-Richtlinie (89/336/EWG, 93/68/EWG)
Directive EMV (89/336/CCE, 93/68/CEE) (Compatibilité
électromagnétique)
Reglamento de compatibilidad electromagnética (89/336/
MCE, 93/68/MCE)

Direttiva sulla bassa tensione (73/23/CEE, 93/68/CEE)
Low voltage guidelines (73/23/EEC, 93/68/EEC)
Tiefe Spannung Richtlinie (73/23/EWG, 93/68/EWG)
Directive bas voltage (73/23/CEE, 93/68/CEE)
Reglamento de bajo Voltaje (73/23/MCE, 93/68/MCE)

Norme armonizzate applicate in particolare:
Applied harmonized standards, in particular:
Angewendete harmonisierte Normen, insbesondere:
Normes harmonisées utilisées, notamment:
Normas armonizadas utilizadas particularmente:

EN 55022, EN 61000-3-2, EN 61000-3-3, EN 50082-1

Norme armonizzate applicate in particolare:
Applied harmonized standards, in particular:
Angewendete harmonisierte Normen, insbesondere:
Normes harmonisées utilisées, notamment:
Normas armonizadas utilizadas particularmente:

EN 60204-1, EN 60335-1

Norme e specifiche tecniche nazionali applicate in
particolare:
Applied national technical standards and specifications, in
particular:

Angewendete nationale Normen und technische
Spezifikationen, insbesondere:
Normes et spécifications techniques nationales qui ont été
utilisées, notamment:
Normas y especificaciones técnicas nacionales que se
utilizaron particularmente:

UNI 8612

Data/Firma

Data/Firma

BENINCA®

Automatismi Benincà Srl
Via Capitello, 45
36066 Sandrigo (VI)
ITALIA

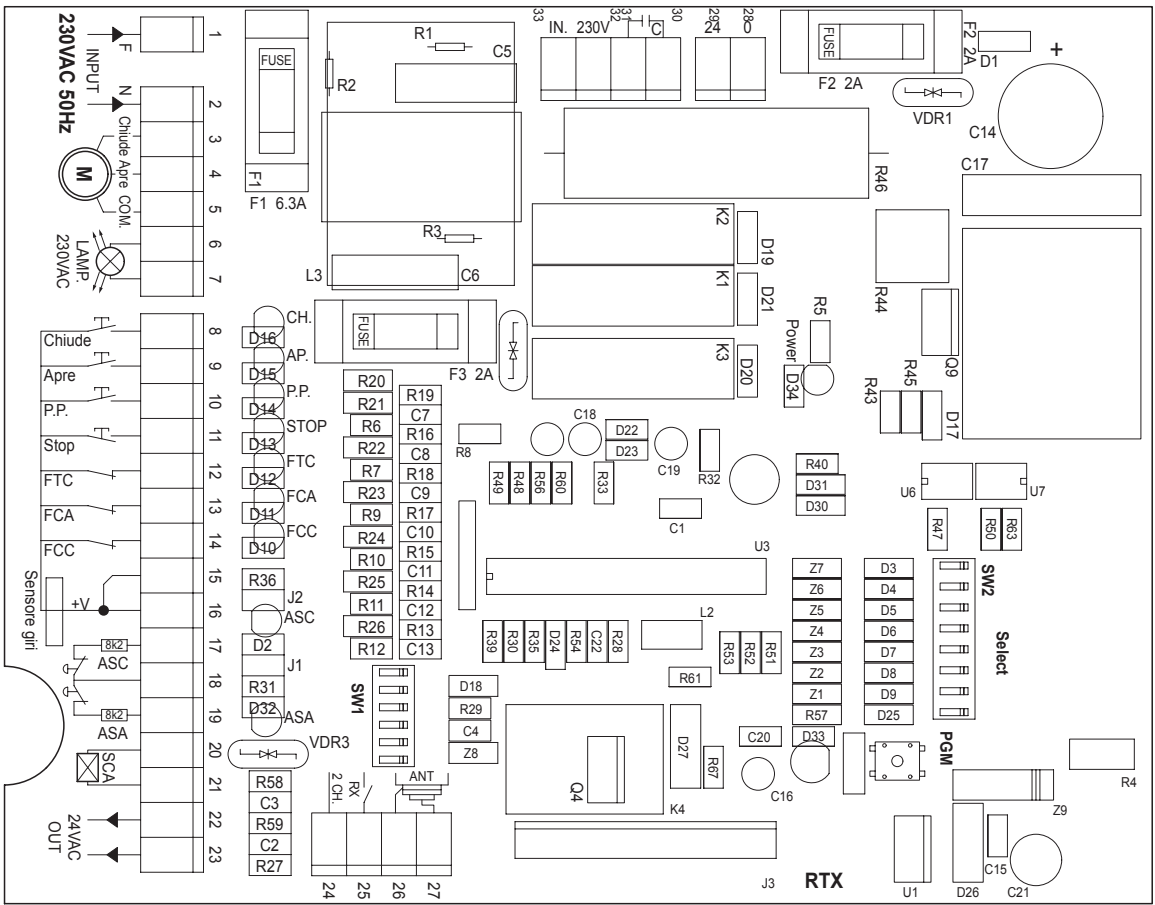

RI15KI Control unit with microcontroller

The control unit with microprocessor RI.15KI can be used to control motors featuring a power not exceeding 750W.

Installation instructions.

- a) Wire connections and operating logic should comply with regulations in force.
- b) It is recommended to keep the power cables (motor, power supply) detached from the control ones (push-buttons, photocells, radio). To avert any interference, it is advised to use two distinct sheaths.
- c) Before powering the unit, rapidly check all connections.
- d) Check the correct setting of the Dip-Switches.
- e) When the unit is powered, the LED "POWER" must light on. In the negative, check the good condition of fuses and the presence of 230Vac, 50Hz between terminals 1 and 2 (INPUT 230VAC - follow phase/neutral).
- f) All normally closed inputs, which are not in use, should be short-circuited with the relevant Dip-Switch located near the connection terminal of the inputs.
- g) If the rotation direction of the motor is inverted, it is sufficient to invert the wires "APRE" - "CHIUDE" (OPEN - CLOSE) of the motor as well as the limit switches wires "FCA" - "FCC".

Input/Output functions

- (1,2) Input, 230VAC= Power supply of the control unit 230Vac, 50Hz (Phase: terminal 2, Neutral: terminal 1).
- (3,4,5) Output, Motor= Respectively, Close (3), Open (4) and Common (5).
- (6,7) LAMP= To the flashing light at 230Vac
- (8) CHIUDE= Normally Open (N.O.) contact
- (9) APRE= N.O. contact (it can be switched to "Pedestrian" input)
- (10) P.P.= Input, STEP-BY-STEP. Connected in parallel to the remote control. N.O. contact.
- (11) STOP= Normally closed (N.C.) contact
- (12) FTC= To be connected to the output terminal of the photocell. N.C. contact
- (13) FCA= Input, opening limit switch. N.C. contact
- (14) FCC= Input, closing limit switch. N.C. contact
- (15,16) +V= Output, common for all inputs
- (17) ASC= Input, safety edge. Its activation causes the movement reversion for 1 second if the motor is in the closing phase*
- (18) Input, common to the safety edges = Input, common of safety edges. The safety edges **MUST NOT BE CONNECTED TO THE COMMON OF THE PUSH-BUTTONS**
- (19) ASA= Input, safety edge. Its activation causes the movement reversion for 1 second if the motor is in the opening phase*
- (20,21) SCA= "Open gate LED" contact, 24Vac bulb
- (22,23) OUT 24VAC= Output, auxiliary power supply, 24Vac (1A max.)
- (24,25) Output, 2nd channel= N.O. contact, controlled by the second channel of the remote control
- (26,27) Input, antenna= Antenna connection for the receiving card of the remote control.
Display= terminal 25
- (28,29) Input, 24VAC= Connection to the secondary of the transformer, 24V
- (30,31) Capacitor= Connection to the capacitor
- (32,33) Output, 230VAC= Connection to the primary of the transformer, 24V
RTX= Connector to the receiving card of the remote control.

* The inputs of the safety edges are at calibrated resistance. If a resistive safety edge is used, the relevant jumpers (J2 for ASC and J1 for ASA) should be closed. Conversely, if a mechanical edge is used the jumpers should be left open. In the event the safety edges are not mounted, leave the corresponding jumper open and move the short-circuit Dip-Switch to ON (No. 1 for ASA and no. 2 for ASC).
N.B.: for the safety edge, two inputs are provided, **NEVER CONNECT THE SAFETY EDGE TO THE COMMON TERMINAL.**

CAUTION: When the control unit is powered, do not touch any metallic parts.

DSW1 Operating mode of the "P.P. button" and of the remote control.

Off: Open/Stop/Close sequence

On: Open/Close/Open sequence

DSW2 "Service man" function. The automatic system carries out the opening and closing operations as long as the Open and Close push-buttons, respectively are kept pressed.

Off: Service Man function disabled

On: Service man function enabled. In this case the Open push-button cannot be used as control for pedestrian use.

- DSW3 "Multiple-flat" function: the "P.P." (STEP-BY-STEP) input does not cause the motor stopping in the opening phase. At end of opening, the "P.P." input is enabled for the gate closure.
 Off: Multiple-flat function is disabled
 On: Multiple-flat function is enabled
- DSW4 "Forewarning" function: the flashing light switches on 3 seconds before the beginning of every movement.
 Off: Forewarning flashing light is disabled
 On: Forewarning flashing light is enabled
- DSW5 Photocell activation during the opening phase. If the photocell beam is obscured, the motor stops. The movement starts after 1 second from the photocell reset.
 Off: No activation
 On: Temporary stop
- DSW6 "Pedestrian" function: the "Open" input controls the temporary opening (adjustable from about 1.5 to 10 metres).
 Off: Operation as "Open Push-button"
 On: Operation as "Pedestrian push-button"
- DSW7 Pick-up at start
 Off: Pick-up at start disabled
 On: Pick-up at start enabled
- DSW8 Automatic closure.
 Off: Automatic closure disabled
 On: Automatic closure enabled

The selections which are preset with the Dip-Switches are memorized in the Stop phase. If a variation to the configuration of the Dip-Switches is carried out, the control unit operation is modified after the following stop.

Dip-Switch "Bypass" Function

The Dip-Switches "Bypass" allow to short-circuit the normally closed inputs that are not in use.

- DSW1 Input ASA
 Off= Enabled input
 On= Disabled input (leave the gate open).
- DSW2 Input ASC
 Off= Enabled input
 On= Disabled input (leave the gate open).
- DSW3 Input FCC
 Off= Enabled input
 On= Disabled input.
- DSW4 Input FCA
 Off= Enabled input
 On= Disabled input.
- DSW5 Input FTC
 Off= Enabled input
 On= Disabled input.
- DSW6 Input STOP
 Off= Enabled input
 On= Disabled input.

Programmable functions



The RI.15KI control unit is equipped with connector to communicate with the programming display. If the display is not used, the control unit can be programmed as follows:



The functions for which it is possible to choose between a range of values can be preset by using the programming push-button (PGM) together with the Dip-switches. The fixed values are indicated with "(def.)". To store the programmable functions in memory, move the Dip-switches as shown in the table, then press the push-button PGM for at least 2 seconds. The light of the "PGM" LED, which normally flashes, will be steady. When the LED switches off, then the programming has been successfully carried out. At this point, the push-button can be released and the LED start flashing.

At completion of the programming procedure, move the Dip-switches to the normal positions.

This control unit performs the power circuit integrity test automatically. Should a fault be detected, the unit stops and indicates the fault through two blinks of the PGM led in rapid succession.

The triggering of the thermal switch is considered a fault in the power circuit, and once the thermal protection is reset, the control unit restarts automatically. If the control unit keeps on indicating a faulty operation, even when the motor has cooled down, try to momentarily switch power off.

Function	Options																																																																																					
<p>Dwell time for the automatic closure.</p> <p>Dip-switch 1÷4= On/On/Off/Off</p>  <p>The dwell time is reset when the input FTC contact is opened or the Open input contact stays open.</p>	<table border="1"> <thead> <tr> <th>Dsw5</th> <th>Dsw6</th> <th>Dsw7</th> <th>Dsw8</th> <th>Seconds</th> </tr> </thead> <tbody> <tr><td>Off</td><td>Off</td><td>Off</td><td>Off</td><td>5</td></tr> <tr><td>On</td><td>Off</td><td>Off</td><td>Off</td><td>10</td></tr> <tr><td>Off</td><td>On</td><td>Off</td><td>Off</td><td>15</td></tr> <tr><td>On</td><td>On</td><td>Off</td><td>Off</td><td>20</td></tr> <tr><td>Off</td><td>Off</td><td>On</td><td>Off</td><td>30</td></tr> <tr><td>On</td><td>Off</td><td>On</td><td>Off</td><td>40</td></tr> <tr><td>Off</td><td>On</td><td>On</td><td>Off</td><td>50</td></tr> <tr><td>On</td><td>On</td><td>On</td><td>Off</td><td>60 (def.)</td></tr> <tr><td>Off</td><td>Off</td><td>Off</td><td>On</td><td>80</td></tr> <tr><td>On</td><td>Off</td><td>Off</td><td>On</td><td>100</td></tr> <tr><td>Off</td><td>On</td><td>Off</td><td>On</td><td>120</td></tr> <tr><td>On</td><td>On</td><td>Off</td><td>On</td><td>140</td></tr> <tr><td>Off</td><td>Off</td><td>On</td><td>On</td><td>160</td></tr> <tr><td>On</td><td>Off</td><td>On</td><td>On</td><td>180</td></tr> <tr><td>Off</td><td>On</td><td>On</td><td>On</td><td>200</td></tr> <tr><td>On</td><td>On</td><td>On</td><td>On</td><td>220</td></tr> </tbody> </table>	Dsw5	Dsw6	Dsw7	Dsw8	Seconds	Off	Off	Off	Off	5	On	Off	Off	Off	10	Off	On	Off	Off	15	On	On	Off	Off	20	Off	Off	On	Off	30	On	Off	On	Off	40	Off	On	On	Off	50	On	On	On	Off	60 (def.)	Off	Off	Off	On	80	On	Off	Off	On	100	Off	On	Off	On	120	On	On	Off	On	140	Off	Off	On	On	160	On	Off	On	On	180	Off	On	On	On	200	On	On	On	On	220
Dsw5	Dsw6	Dsw7	Dsw8	Seconds																																																																																		
Off	Off	Off	Off	5																																																																																		
On	Off	Off	Off	10																																																																																		
Off	On	Off	Off	15																																																																																		
On	On	Off	Off	20																																																																																		
Off	Off	On	Off	30																																																																																		
On	Off	On	Off	40																																																																																		
Off	On	On	Off	50																																																																																		
On	On	On	Off	60 (def.)																																																																																		
Off	Off	Off	On	80																																																																																		
On	Off	Off	On	100																																																																																		
Off	On	Off	On	120																																																																																		
On	On	Off	On	140																																																																																		
Off	Off	On	On	160																																																																																		
On	Off	On	On	180																																																																																		
Off	On	On	On	200																																																																																		
On	On	On	On	220																																																																																		
<p>Operating time of the "Pedestrian" function.</p> <p>Dip-switch 1÷4= On/Off/On/Off</p> 	<table border="1"> <thead> <tr> <th>Dsw5</th> <th>Dsw6</th> <th>Dsw7</th> <th>Dsw8</th> <th>Seconds</th> </tr> </thead> <tbody> <tr><td>Off</td><td>Off</td><td>Off</td><td>Off</td><td>5</td></tr> <tr><td>On</td><td>Off</td><td>Off</td><td>Off</td><td>10 (def.)</td></tr> <tr><td>Off</td><td>On</td><td>Off</td><td>Off</td><td>15</td></tr> <tr><td>On</td><td>On</td><td>Off</td><td>Off</td><td>20</td></tr> <tr><td>Off</td><td>Off</td><td>On</td><td>Off</td><td>25</td></tr> <tr><td>On</td><td>Off</td><td>On</td><td>Off</td><td>30</td></tr> <tr><td>Off</td><td>On</td><td>On</td><td>Off</td><td>35</td></tr> <tr><td>On</td><td>On</td><td>On</td><td>Off</td><td>40</td></tr> </tbody> </table>	Dsw5	Dsw6	Dsw7	Dsw8	Seconds	Off	Off	Off	Off	5	On	Off	Off	Off	10 (def.)	Off	On	Off	Off	15	On	On	Off	Off	20	Off	Off	On	Off	25	On	Off	On	Off	30	Off	On	On	Off	35	On	On	On	Off	40																																								
Dsw5	Dsw6	Dsw7	Dsw8	Seconds																																																																																		
Off	Off	Off	Off	5																																																																																		
On	Off	Off	Off	10 (def.)																																																																																		
Off	On	Off	Off	15																																																																																		
On	On	Off	Off	20																																																																																		
Off	Off	On	Off	25																																																																																		
On	Off	On	Off	30																																																																																		
Off	On	On	Off	35																																																																																		
On	On	On	Off	40																																																																																		
<p>Operating power.</p> <p>Dip-switch 1÷4= Off/On/On/Off</p> 	<table border="1"> <thead> <tr> <th>Dsw5</th> <th>Dsw6</th> <th>Dsw7</th> <th>Dsw8</th> <th>Percent.</th> </tr> </thead> <tbody> <tr><td>Off</td><td>Off</td><td>Off</td><td>Off</td><td>Min. Pow.</td></tr> <tr><td>On</td><td>Off</td><td>Off</td><td>Off</td><td></td></tr> <tr><td>Off</td><td>On</td><td>Off</td><td>Off</td><td></td></tr> <tr><td>On</td><td>On</td><td>Off</td><td>Off</td><td></td></tr> <tr><td>Off</td><td>Off</td><td>On</td><td>Off</td><td></td></tr> <tr><td>On</td><td>Off</td><td>On</td><td>Off</td><td></td></tr> <tr><td>Off</td><td>On</td><td>On</td><td>Off</td><td></td></tr> <tr><td>On</td><td>On</td><td>On</td><td>Off</td><td>(def.)</td></tr> <tr><td>Off</td><td>Off</td><td>Off</td><td>On</td><td></td></tr> <tr><td>On</td><td>Off</td><td>Off</td><td>On</td><td></td></tr> <tr><td>Off</td><td>On</td><td>Off</td><td>On</td><td></td></tr> <tr><td>On</td><td>On</td><td>Off</td><td>On</td><td></td></tr> <tr><td>Off</td><td>Off</td><td>On</td><td>On</td><td></td></tr> <tr><td>On</td><td>Off</td><td>On</td><td>On</td><td></td></tr> <tr><td>Off</td><td>On</td><td>On</td><td>On</td><td></td></tr> <tr><td>On</td><td>On</td><td>On</td><td>On</td><td>Max Pow.</td></tr> </tbody> </table>	Dsw5	Dsw6	Dsw7	Dsw8	Percent.	Off	Off	Off	Off	Min. Pow.	On	Off	Off	Off		Off	On	Off	Off		On	On	Off	Off		Off	Off	On	Off		On	Off	On	Off		Off	On	On	Off		On	On	On	Off	(def.)	Off	Off	Off	On		On	Off	Off	On		Off	On	Off	On		On	On	Off	On		Off	Off	On	On		On	Off	On	On		Off	On	On	On		On	On	On	On	Max Pow.
Dsw5	Dsw6	Dsw7	Dsw8	Percent.																																																																																		
Off	Off	Off	Off	Min. Pow.																																																																																		
On	Off	Off	Off																																																																																			
Off	On	Off	Off																																																																																			
On	On	Off	Off																																																																																			
Off	Off	On	Off																																																																																			
On	Off	On	Off																																																																																			
Off	On	On	Off																																																																																			
On	On	On	Off	(def.)																																																																																		
Off	Off	Off	On																																																																																			
On	Off	Off	On																																																																																			
Off	On	Off	On																																																																																			
On	On	Off	On																																																																																			
Off	Off	On	On																																																																																			
On	Off	On	On																																																																																			
Off	On	On	On																																																																																			
On	On	On	On	Max Pow.																																																																																		

Function	Options																																																																																																																																																																																																						
Programmable functions. Dip-switch 1+4= Off/On/Off/Off 	<p>DSW5 On= In case of failure of the protection devices, the system switches automatically to "Service Man" operating mode after pressing the push-button for 2 seconds. Off= In case of failure of the protection devices, the system cannot be activated even after pressing the push-button (def.).</p> <p>DSW6 On= Braking enabled. About 7 seconds before the end of the operating time, the control unit sends a braking control signal (def.). Off= Braking disabled.</p> <p>DSW7= Off</p> <p>DSW8= Off</p>																																																																																																																																																																																																						
<p>The work time is regulated with the following menu, after the motor has been started from the limit switch; 7 seconds before the set time has elapsed the control unit starts slowing down (if this has been selected). If the work time is modified before you have been able to see the correct operation of the control unit, you must make it perform a complete manoeuvre (that is with arrival on a limit switch and restarting from the same point). The intervention of the protection edges deactivates slowing down until the first subsequent complete manoeuvre (that is with arrival on a limit switch and restarting from the same point).</p>																																																																																																																																																																																																							
Operating time. Dip-switch 1+3= Off/Off/On 	<table border="1"> <thead> <tr> <th>Dsw4</th> <th>Dsw5</th> <th>Dsw6</th> <th>Dsw7</th> <th>Dsw8</th> <th>Seconds</th> </tr> </thead> <tbody> <tr><td>Off</td><td>Off</td><td>Off</td><td>Off</td><td>Off</td><td>15</td></tr> <tr><td>On</td><td>Off</td><td>Off</td><td>Off</td><td>Off</td><td>18</td></tr> <tr><td>Off</td><td>On</td><td>Off</td><td>Off</td><td>Off</td><td>21</td></tr> <tr><td>On</td><td>On</td><td>Off</td><td>Off</td><td>Off</td><td>24</td></tr> <tr><td>Off</td><td>Off</td><td>On</td><td>Off</td><td>Off</td><td>27</td></tr> <tr><td>On</td><td>Off</td><td>On</td><td>Off</td><td>Off</td><td>30</td></tr> <tr><td>Off</td><td>On</td><td>On</td><td>Off</td><td>Off</td><td>33</td></tr> <tr><td>On</td><td>On</td><td>On</td><td>Off</td><td>Off</td><td>36</td></tr> <tr><td>Off</td><td>Off</td><td>Off</td><td>On</td><td>Off</td><td>39</td></tr> <tr><td>On</td><td>Off</td><td>Off</td><td>On</td><td>Off</td><td>42</td></tr> <tr><td>Off</td><td>On</td><td>Off</td><td>On</td><td>Off</td><td>45</td></tr> <tr><td>On</td><td>On</td><td>Off</td><td>On</td><td>Off</td><td>48</td></tr> <tr><td>Off</td><td>Off</td><td>On</td><td>On</td><td>Off</td><td>51</td></tr> <tr><td>On</td><td>Off</td><td>On</td><td>On</td><td>Off</td><td>54</td></tr> <tr><td>Off</td><td>On</td><td>On</td><td>On</td><td>Off</td><td>57 (def.)</td></tr> <tr><td>On</td><td>On</td><td>On</td><td>On</td><td>Off</td><td>60</td></tr> <tr><td>Off</td><td>Off</td><td>Off</td><td>Off</td><td>On</td><td>63</td></tr> <tr><td>On</td><td>Off</td><td>Off</td><td>Off</td><td>On</td><td>66</td></tr> <tr><td>Off</td><td>On</td><td>Off</td><td>Off</td><td>On</td><td>69</td></tr> <tr><td>On</td><td>On</td><td>Off</td><td>Off</td><td>On</td><td>72</td></tr> <tr><td>Off</td><td>Off</td><td>On</td><td>Off</td><td>On</td><td>75</td></tr> <tr><td>On</td><td>Off</td><td>On</td><td>Off</td><td>On</td><td>78</td></tr> <tr><td>Off</td><td>On</td><td>On</td><td>Off</td><td>On</td><td>81</td></tr> <tr><td>On</td><td>On</td><td>On</td><td>Off</td><td>On</td><td>84</td></tr> <tr><td>Off</td><td>Off</td><td>Off</td><td>On</td><td>On</td><td>87</td></tr> <tr><td>On</td><td>Off</td><td>Off</td><td>On</td><td>On</td><td>90</td></tr> <tr><td>Off</td><td>On</td><td>Off</td><td>On</td><td>On</td><td>93</td></tr> <tr><td>On</td><td>On</td><td>Off</td><td>On</td><td>On</td><td>96</td></tr> <tr><td>Off</td><td>Off</td><td>On</td><td>On</td><td>On</td><td>99</td></tr> <tr><td>On</td><td>Off</td><td>On</td><td>On</td><td>On</td><td>102</td></tr> <tr><td>Off</td><td>On</td><td>On</td><td>On</td><td>On</td><td>105</td></tr> <tr><td>On</td><td>On</td><td>On</td><td>On</td><td>On</td><td>108</td></tr> </tbody> </table>	Dsw4	Dsw5	Dsw6	Dsw7	Dsw8	Seconds	Off	Off	Off	Off	Off	15	On	Off	Off	Off	Off	18	Off	On	Off	Off	Off	21	On	On	Off	Off	Off	24	Off	Off	On	Off	Off	27	On	Off	On	Off	Off	30	Off	On	On	Off	Off	33	On	On	On	Off	Off	36	Off	Off	Off	On	Off	39	On	Off	Off	On	Off	42	Off	On	Off	On	Off	45	On	On	Off	On	Off	48	Off	Off	On	On	Off	51	On	Off	On	On	Off	54	Off	On	On	On	Off	57 (def.)	On	On	On	On	Off	60	Off	Off	Off	Off	On	63	On	Off	Off	Off	On	66	Off	On	Off	Off	On	69	On	On	Off	Off	On	72	Off	Off	On	Off	On	75	On	Off	On	Off	On	78	Off	On	On	Off	On	81	On	On	On	Off	On	84	Off	Off	Off	On	On	87	On	Off	Off	On	On	90	Off	On	Off	On	On	93	On	On	Off	On	On	96	Off	Off	On	On	On	99	On	Off	On	On	On	102	Off	On	On	On	On	105	On	On	On	On	On	108
Dsw4	Dsw5	Dsw6	Dsw7	Dsw8	Seconds																																																																																																																																																																																																		
Off	Off	Off	Off	Off	15																																																																																																																																																																																																		
On	Off	Off	Off	Off	18																																																																																																																																																																																																		
Off	On	Off	Off	Off	21																																																																																																																																																																																																		
On	On	Off	Off	Off	24																																																																																																																																																																																																		
Off	Off	On	Off	Off	27																																																																																																																																																																																																		
On	Off	On	Off	Off	30																																																																																																																																																																																																		
Off	On	On	Off	Off	33																																																																																																																																																																																																		
On	On	On	Off	Off	36																																																																																																																																																																																																		
Off	Off	Off	On	Off	39																																																																																																																																																																																																		
On	Off	Off	On	Off	42																																																																																																																																																																																																		
Off	On	Off	On	Off	45																																																																																																																																																																																																		
On	On	Off	On	Off	48																																																																																																																																																																																																		
Off	Off	On	On	Off	51																																																																																																																																																																																																		
On	Off	On	On	Off	54																																																																																																																																																																																																		
Off	On	On	On	Off	57 (def.)																																																																																																																																																																																																		
On	On	On	On	Off	60																																																																																																																																																																																																		
Off	Off	Off	Off	On	63																																																																																																																																																																																																		
On	Off	Off	Off	On	66																																																																																																																																																																																																		
Off	On	Off	Off	On	69																																																																																																																																																																																																		
On	On	Off	Off	On	72																																																																																																																																																																																																		
Off	Off	On	Off	On	75																																																																																																																																																																																																		
On	Off	On	Off	On	78																																																																																																																																																																																																		
Off	On	On	Off	On	81																																																																																																																																																																																																		
On	On	On	Off	On	84																																																																																																																																																																																																		
Off	Off	Off	On	On	87																																																																																																																																																																																																		
On	Off	Off	On	On	90																																																																																																																																																																																																		
Off	On	Off	On	On	93																																																																																																																																																																																																		
On	On	Off	On	On	96																																																																																																																																																																																																		
Off	Off	On	On	On	99																																																																																																																																																																																																		
On	Off	On	On	On	102																																																																																																																																																																																																		
Off	On	On	On	On	105																																																																																																																																																																																																		
On	On	On	On	On	108																																																																																																																																																																																																		

BENINCA®

AUTOMATISMI BENINCA Srl - Via Capitello, 45 - 36066 Sandrigo (VI) - Tel. 0444 751030 r.a. - Fax 0444 759728
