

L8542343
Rev. 08/07/01

BENINCA®

CENTRALE DI COMANDO
CONTROL UNIT
STEUEREINHEIT
CENTRALE DE COMMANDE
CENTRAL DE MANDO
CENTRALKA STEROWANIA

CP.RI624N

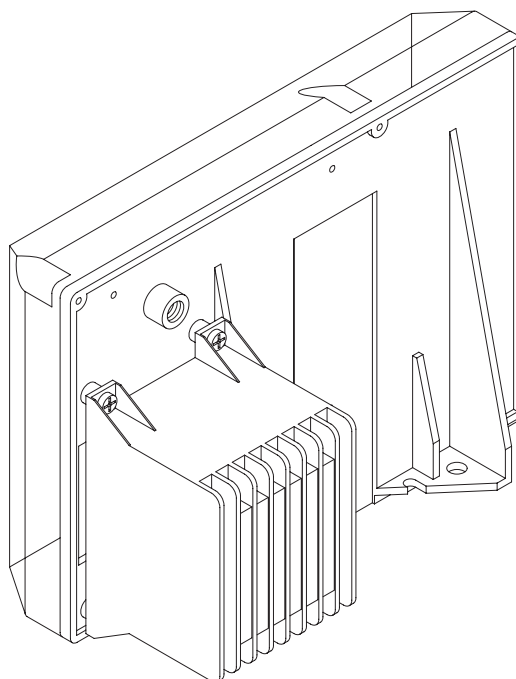

Libro istruzioni
Operating instructions
Betriebsanleitung
Livret d'instructions
Manual de instrucciones
Książeczka z instrukcjami



UNIONE NAZIONALE COSTRUTTORI
AUTOMATISMI PER CANCELLI, PORTE,
SERRANDE ED AFFINI

Dichiarazione CE di conformità
EC declaration of conformity
EG-Konformitätserklärung

Déclaration CE de conformité
Declaracion CE de conformidad
Deklaracja UE o zgodności

Con la presente dichiariamo che il nostro prodotto
We hereby declare that our product
Hiermit erklaren wir, dass unser Produkt
Nous déclarons par la présente que notre produit
Por la presente declaramos que nuestro producto
Niniejszym oświadczamy że nasz produkt

CP.RI624N

è conforme alle seguenti disposizioni pertinenti:
complies with the following relevant provisions:
folgenden einschlagigen Bestimmungen entspricht:
correspond aux dispositions pertinentes suivantes:
satisface las disposiciones pertinentes siguientes:
zgodny jest z poniżej wyszczególnionymi rozporządzeniami:

Direttiva sulla compatibilità elettromagnetica
(89/336/CCE, 93/68/CEE)
EMC guidelines (89/336/EEC, 93/68/EEC)
EMV-Richtlinie (89/336/EWG, 93/68/EWG)
Directive EMV (89/336/CCE, 93/68/CEE)
(Compatibilité électromagnétique)
Reglamento de compatibilidad electromagnética
(89/336/MCE, 93/68/MCE)
Wytyczna odnośnie zdolności współdziałania elektromagne-
tycznego (89/336/EWG, 93/68/EWG)

Direttiva sulla bassa tensione (73/23/CEE, 93/68/CEE)
Low voltage guidelines (73/23/EEC, 93/68/EEC)
Tiefe Spannung Richtlinie (73/23/EWG, 93/68/EWG)
Directive bas voltage (73/23/CEE, 93/68/CEE)
Reglamento de bajo Voltaje (73/23/MCE, 93/68/MCE)
Wytyczna odnośnie niskiego napięcia (73/23/EWG,
93/68/EWG)

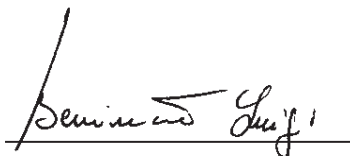

Benincà Luigi, Responsabile legale.
Sandrigo, 05/10/2005.

BENINCA®

Automatismi Benincà SpA
Via Capitello, 45
36066 Sandrigo (VI)
ITALIA

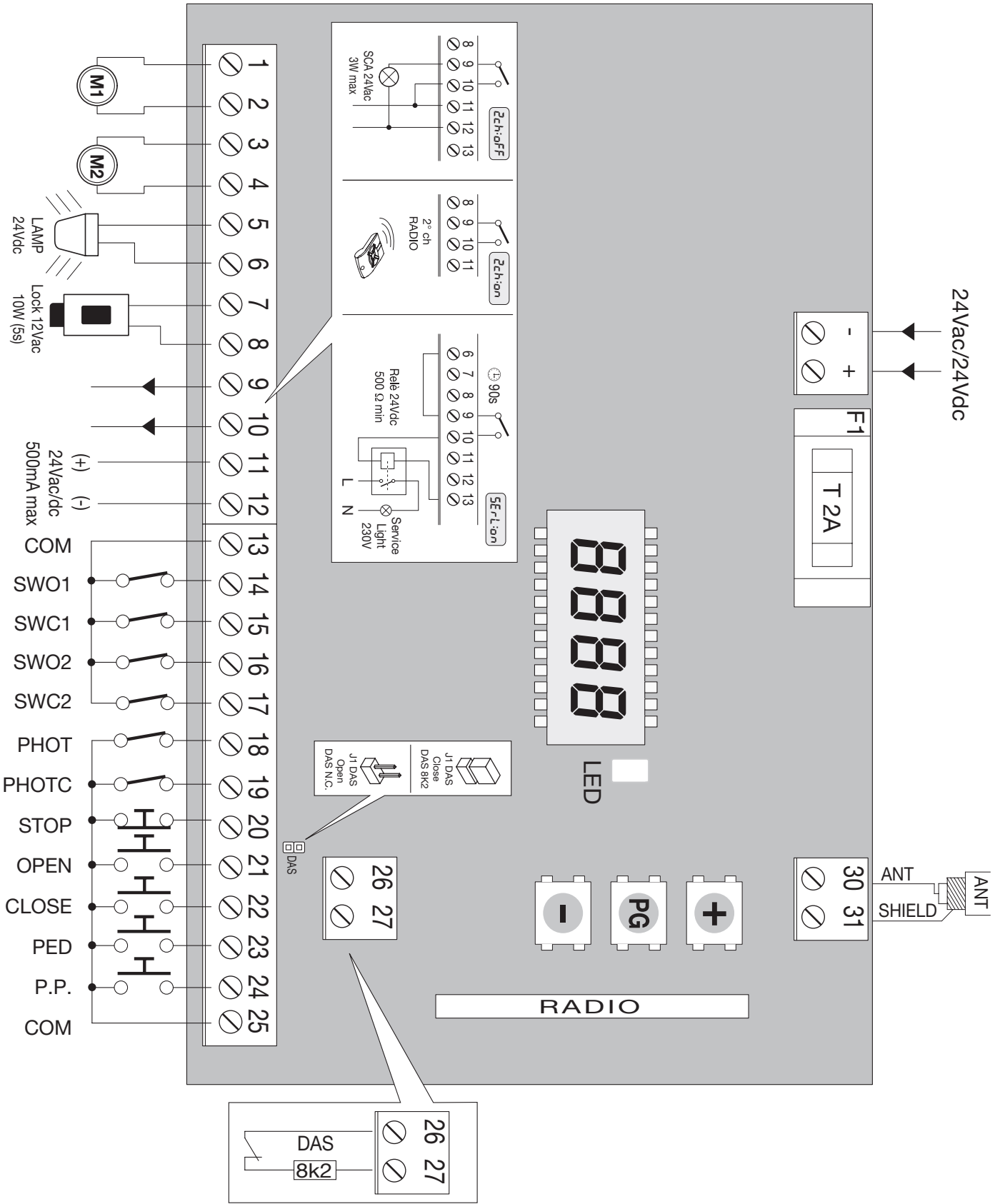

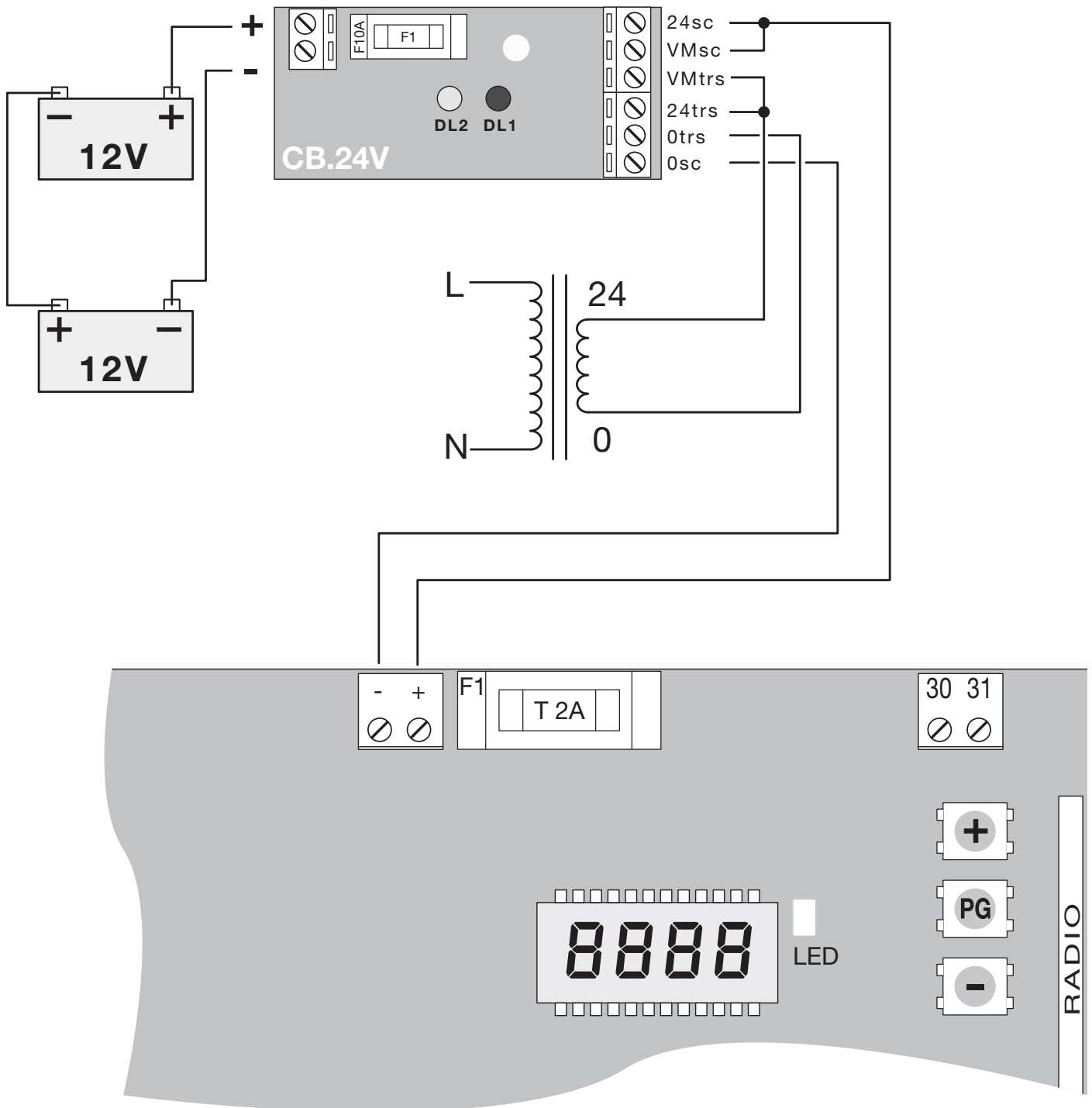

Collegamento scheda CB.24V (opzionale)
Connection to the CB.24V Card (optional)
Anschluss Karte CB.24V (Option)
Branchement fiche CB.24V (optionnel)
Conexión tarjeta CB.24V (opcional)
Połączenie karty CB.24V (opcjonalna)

CP.RI624N control unit

The **CP.RI624N** electronic control unit may be used for the control of 1 or 2 motors 24Vdc with power not higher than 120W+120W.

GENERAL WARNINGS

- a) The electrical installation and the operating logic must comply with the regulations in force.
- b) The leads fed with different voltages must be physically separate, or they must be suitably insulated with additional insulation of at least 1 mm.
- c) The leads must be secured with an additional fixture near the terminals.
- d) Check all the connections again before switching on the power.
- e) The unused N.C. inputs must be bridged.

INPUT/OUTPUT FUNCTIONS

CP.RI624N Control unit		
Terminal No.	Function	Description
1-2	Motor 1	Connection, motor 1: 24VDC 120W max
3-4	Motor 2	Connection, motor 2: 24VDC 120W max
5-6	Flashing light	Connection, flashing light 24VDC 15W max.
7-8	Lock	Output, 12VAC/10W (5s) power supply for electric lock (7:0V, 8:+12V)
9-10	SCA/2°Ch radio	Normally open clean contact. Controlled by "2Ch" logic. With 2ch logic Off: SCA contact, open gate indicator. With 2ch logic On: Contact controlled by 2 nd radio channel of the receiver. Note: with "SRL" logic On, it performs the contact function of the courtesy light control, see table of logic.
11-12	24 Vac/dc	Output, accessory power supply, 24VAC/0.5A max. IMPORTANT: If the battery charger board CB.24V is installed, the output (without mains power connected) has a 24Vdc polarised voltage. Make sure the devices are correctly connected (i.e. 11:+24Vdc / 12:-0Vdc).
13	COM	Common for limit switches and all control inputs.
14	SWO1	Input, OPEN limit switch, motor 1 (Normally closed contact)
15	SWC1	Input, CLOSE limit switch, motor 1 (Normally closed contact)
16	SWO2	Input, OPEN limit switch, motor 2 (Normally closed contact)
17	SWC2	Input, CLOSE limit switch, motor 2 (Normally closed contact)
18	PHOT	Input, photocell activated in both opening and closing phases
19	PHOT C	Input, photocell activated in closing phase only
20	STOP	Input, STOP push-button (Normally closed contact)
21	OPEN	Input, OPEN push-button (Normally open contact).
22	CLOSE	Input, CLOSE push-button (Normally open contact)
23	PED	Input, push-button for pedestrian use (Normally open contact), it controls the complete opening of motor 1
24	Step-by-Step	Input, step-by-step push button (Normally open contact)
25	COM	Common for all control inputs.
26-27	BAR	Input, sensitive edge contact Resistive edge: "DAS" Jumper closed Mechanical edge: "DAS" Jumper open When the edge is activated, the gate movement is stopped and reversed for about 3s.
30-31	Antenna	Connection to the insertable radio receiver card (30-signal/31-screen).
JF1-JF2	24VAC/dc	Input, 24VAC/24VDC power supply. If buffer batteries are used, connect the CB.24V card (in option) as indicated in the table.

PROGRAMMING

The programming of the various functions of the control unit is carried out using the LCD display on the control unit and setting the desired values in the programming menus described below.

The parameters menu allows you to assign a numerical value to a function, in the same way as a regulating trimmer.

The logic menu allows you to activate or deactivate a function, in the same way as setting a dip-switch.

Other special functions follow the parameters and logic menus and may vary depending on the type of control unit or the software release.

The control unit is complete with an incorporated radio receiver for both fixed-code and variable code radio controls, at 433.92MHz frequency.

To use a radio control, its code should be copied first. The memorization procedure is shown here under (RADIO menu). The device is able to store up to 64 different codes in memory.

TO ACCESS PROGRAMMING:

- 1 - Press the button <PG>, the display goes to the first menu, Parameters "PAR".
- 2 - With the <+> or <-> button, select the menu you want (PAR>>LOG>>RADIO>>NMAN>>RES>>PAR>>....).
- 3- Press the button <PG>, the display shows the first function available on the menu.
- 4 - With the <+> or <-> button, select the function you want.
- 5 - Press the button <PG>, the display shows the value currently set for the function selected.
- 6 - With the <+> or <-> button, select the value you intend to assign to the function.
- 7 - Press the button <PG>, the display shows the signal "PRG" which indicates that programming has been completed.

NOTES:

Simultaneously pressing <+> and <-> from inside a function menu allows you to return to the previous menu without making any changes.

Simultaneously pressing <+> and <-> when the display is switched off shows the card software release.

Hold down the <+> key or the <-> key to accelerate the increase/decrease of the values.

After waiting 60s the control unit quits programming mode and switches off the display.

PARAMETERS, LOGIC AND SPECIAL FUNCTIONS

The tables below describe the individual functions available in the control unit.

	MENU	FUNCTION	Settable values MIN-MAX-(Default)	MEMO
PARAMETERS	t _{cA}	Automatic closing time. Active only with logic "TCA"=ON. At the end of the set time the control unit orders a closing manoeuvre.	1-240-(40s)	
	t _{n1}	Operating time, motor 1. The operating time is adjusted at normal speed during motor 1 opening and closing phases. See section "Adjustment of braking".	15-180-(8s)	
	t _{n2}	Operating time, motor 2. The operating time is adjusted at normal speed during motor 2 opening and closing phases. See section "Adjustment of braking".	15-180-(8s)	
	P _{no1}	The torque applied to motor 1 during the opening phase is adjusted.*	1-99-(50%)	
	P _{nc1}	The torque applied to motor 1 during the closing phase is adjusted.*	1-99-(50%)	
	P _{no2}	The torque applied to motor 2 during the opening phase is adjusted.*	1-99-(50%)	
	P _{nc2}	The torque applied to motor 2 during the closing phase is adjusted.*	1-99-(50%)	
	t _{dno}	Mot.2 opening delay time. Regulates the delay time of motor 2 on opening with respect to motor 1	0-15-(0s)	
	t _{dn1c}	Mot.1 closing delay time Regulates the delay time of motor 1 on closing with respect to motor 2	0-40-(0s)	
	t _{Loc}	Electric lock activation time. If the electric lock is not used, set the parameter at 0.	0-5-(3s)	
	SL _{d5}	The motor speed during braking is adjusted. The value is expressed in percentage with respect to speed during normal operation.	30-99 (50)	
	P _{so1}	The torque applied to motor 1 during braking in the opening phase is adjusted *	1-99-(50%)	
	P _{sc1}	The torque applied to motor 1 during braking in the closing phase is adjusted *	1-99-(50%)	
	P _{so2}	The torque applied to motor 2 during braking in the opening phase is adjusted *	1-99-(50%)	
P _{sc2}	The torque applied to motor 2 during braking in the closing phase is adjusted *	1-99-(50%)		

*** WARNING: An incorrect setting of these parameters may result in an hazard. Comply with regulations in force!**

ADJUSTMENT OF BRAKING

With braking enabled (SLD logic: ON), braking will start at end of time preset with TM1 and TM2.

The preset time should therefore be lower than the real stroke of the operator. For example, with a 20s stroke, preset 17s to start the braking phase, 3s in advance with respect to end of movement.

The speed of the motor during braking is determined by the SLDS parameter value.

MENU	FUNCTION	Settable values ON-OFF-(Default)	MEMO
<i>tca</i>	Enables or disables automatic closing On: automatic closing enabled Off: automatic closing disabled	(ON)	
<i>ibl</i>	Enables or disables condominium function. On: condominium function enabled. The step-by-step impulse or transmitter impulse has no effect during the opening phase. Off: condominium function disabled.	(OFF)	
<i>scL</i>	Enables or disables rapid closing On: rapid closing enabled. With the gate open or in the opening phase the intervention of the photocell causes automatic closing after 3 s. Active only with TCA:ON. Off: rapid closing disabled.	(OFF)	
<i>SLd</i>	Enables or disables slowing. On: Slowing active. Off: Slowing excluded.	(ON)	
<i>pp</i>	Selects the operating mode of the "Step by step button" and of the transmitter. On: Operation: OPEN > CLOSE > OPEN > Off: Operation: OPEN > STOP > CLOSE > STOP >	(OFF)	
<i>PrE</i>	Enables or disables pre-blinking. On: Pre-blinking enabled. Blinking is activated 3s before the motor starts. Off: Pre-blinking disabled.	(OFF)	
<i>bLc</i>	The lock function is enabled or disabled. On: Lock function enabled. After the activation of closure limit switches the control unit delays the stop by approx. 0.5s in order to allow a better resting of the gate against the stoppers. Off: Lock function disabled.	(OFF)	
<i>cLoc</i>	Selects the mode of the OPEN input On: OPEN input with CLOCK function. To be used for connection to a timer for timed opening/closing. (Contact CLOSED- gate open, Contact open, normal operation). Off: OPEN input with OPEN function	(OFF)	
<i>htr</i>	Enables or disables Man present function. On: Man Present operation. The OPEN/CLOSE buttons must be held down during the whole manoeuvre. Off: Automatic operation.	(OFF)	
<i>nLoc</i>	Selects the type of electric lock used. On: Magnetic electric lock, normally fed at 12Vac/0,5A max. Before each opening manoeuvre the power supply is interrupted for the time set by the parameter TLOC. Off: Electric lock with latch, normally not fed. Before each opening manoeuvre power is fed at 12Vac for the time set by the parameter TLOC.	(OFF)	
<i>inot</i>	Select the 1/2 motors operating mode: On: Only motor 1 operating. Off: Both motors operating.	(ON)	

LOGIC

	MENU	FUNCTION	Settable values ON-OFF-(Default)	MEMO
LOGIC	<i>cuAr</i>	The code programmable transmitters is enabled or disabled. On: Radio receiver enabled only for rolling-code transmitters. Off: Receiver enabled for rolling-code and programmable code transmitters (self-learning and Dip Switch).	OFF	
	<i>noLS</i>	The operation mode of the amperometric sensor is selected either the limit switches are provided or not. On: Limit switches not provided. The amperometric sensor activation is interpreted by the control unit as limit switch. The control signal is sent to stop the movement. Note: To use this function, close the limit switch contacts with jumpers. The "SLD" Logic should be positioned to OFF Off: Limit switches provided. The amperometric sensor activation is interpreted by the control unit as obstacle present in the gate movement area. Similarly to the safety edge activation, the control signal is sent to stop and reverse movement for approx. 3s.	(OFF)	
	<i>2ch</i>	The output performance at Terminals 9-10: On: The output has the function of 2 nd radio channel: the normally open contact switches for 1s at reception of a radio control assigned to the 2 nd radio channel. See radio menu. Off: The output has the SCA function, open gate LED: open contact with closed gate, flashing light during gate movement, closed contact with open gate. See wire diagram.	(OFF)	
	<i>SErL</i>	Service light function is enabled or disabled on output 9-10. On: at each movement, the contact is closed for approx. 90s, regardless of the configuration of 2ch parameter. For the light control use the auxiliary relay. Off: The performance of the output is preset by 2ch parameter, see previous parameter.	(OFF)	

	MENU	FUNCTION
RADIO	<i>PP</i>	By selecting this function, the receiver awaits (<i>PU5h</i>) for a transmitter code to be assigned to the step-by-step function. Press the transmitter key to be assigned to this function. If the code is valid, it is stored in memory and OK appears. If the code is not valid, the wording <i>Err</i> is displayed.
	<i>2ch</i>	By selecting this function, the receiver awaits (<i>PU5h</i>) for a transmitter code to be assigned to the second radio channel, on Terminals 9-10. The 2ch logic must be ON, the SERL logic must be OFF. Press the transmitter key to be assigned to this function. If the code is valid, it is stored in memory and OK appears. If the code is not valid, the wording <i>Err</i> is displayed.
	<i>cLr</i>	By selecting this function, the receiver awaits (<i>PU5h</i>) for a transmitter code to be erased from memory. If the code is valid, it is erase and OK appears. If the code is not valid or is not in memory, the wording <i>Err</i> is displayed.
	<i>rEr</i>	Completely erase the receiver memory. Confirmation of operation is required.

	MENU	FUNCTION
	<i>nPAh</i>	Displays the number of complete cycles (open+close) carried out by the automation. When the <PG> button is pressed for the first time, it displays the first 4 figures, the second time it shows the last 4. Example <PG> <i>00 12 >>></i> <PG> <i>3456</i> : made 123.456 cycles.
	<i>rES</i>	RESET of the control unit. ATTENTION!: Returns the control unit to the default values. Pressing the <PG> button for the first time causes blinking of the letters RES, pressing the <PG> button again resets the control unit. Note: The transmitter codes are not erased from the receiver.

EXAMPLE OF PROGRAMMING

Let us suppose it is necessary to:

- set an automatic closing time (TCA) of 100s
- activate pre-blinking

Perform the operations described below step by step:

Step	Press	Display	Notes
1	PG	PRr	First menu
2		tCR	First function of the first menu
3	PG	040	Value currently set for the function selected
4	+↑ -↓	100	Set the desired value with the <+> and <-> keys
5	PG	PrC	The value is programmed
		tCR	When programming has been made, the display goes to the function just set
6	+ -	PRr	Press <+> and <-> simultaneously to go to the higher menu
7	-	LoC	Second menu
8	PG	tCR	First function of the second menu
9	-	PrE	Press <-> several times to select PRE logic
10	PG	oFF	Value currently set for the function selected
11	+↑ -↓	on	Set the desired value with the <+> and <-> keys
12	PG	PrC	The value is programmed
		PrE	When programming has been made, the display goes to the function just set
13	+ -	PRr	Press <+> and <-> simultaneously to go to the higher menu and quit programming or wait 30s.

DIAGNOSTICS

In the event of malfunctions, by pressing key + or - the status of all inputs (limit switches, control and safety) can be displayed. One segment of the display is linked to each input. In the event of failure it switches on according to the following scheme.

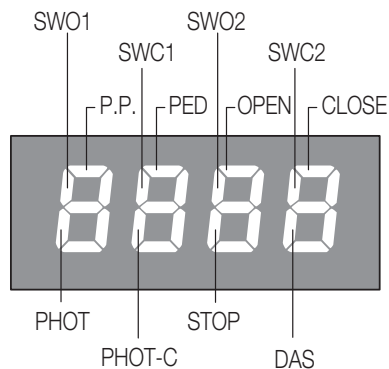

N.C. inputs are represented by the vertical segments. N.O. inputs are represented by the horizontal segments.

<p>For example, with the leaves completely closed the display is as follows:</p>	<p>the moment an Open impulse is given:</p>	<p>during the opening phase:</p>	<p>with the leaves completely open:</p>
--	---	----------------------------------	---

BENINCA[®]

AUTOMATISMI BENINCÀ SpA - Via Capitello, 45 - 36066 Sandrigo (VI) - Tel. 0444 751030 r.a. - Fax 0444 759728
