

RB3 TGL868

User's Manual

GB

Introduction

The RadioBand system is designed of domestic, commercial and industrial door applications where a safety edge is used. The system provides a wireless system replacing spiral cables or energy chain systems to provide the safety signal to the door or gate control panel. The receiver monitors the status of transmitters connected to it.

Up to three transmitters per output can be connected to the receiver. There are two outputs on each receiver that can be connected to the control panel as 8k2 or NC contact.

The transmitter is compatible with 8K2 monitored safety edges or electromechanical safety edges (NC contact), and also with standard low voltage optical safety edges and OSE-S7502 optical safety edges.

The system complies with EN ISO 13849-1, category 2, PLc.

Technical data

Frequency	Multifrequency system 868MHz auto-adjustable
Power supply	3,6V DC (2 x 3,6V LS14500 Li-SOCl ₂)
Operating consumption	12mA
Radiated power	< 25mW
Operating temperature	-20°C - +85°C
Watertighness	IP22
Size	40 x 194,5 x 20mm
Range	100m
Battery life (aprox)	2 Years

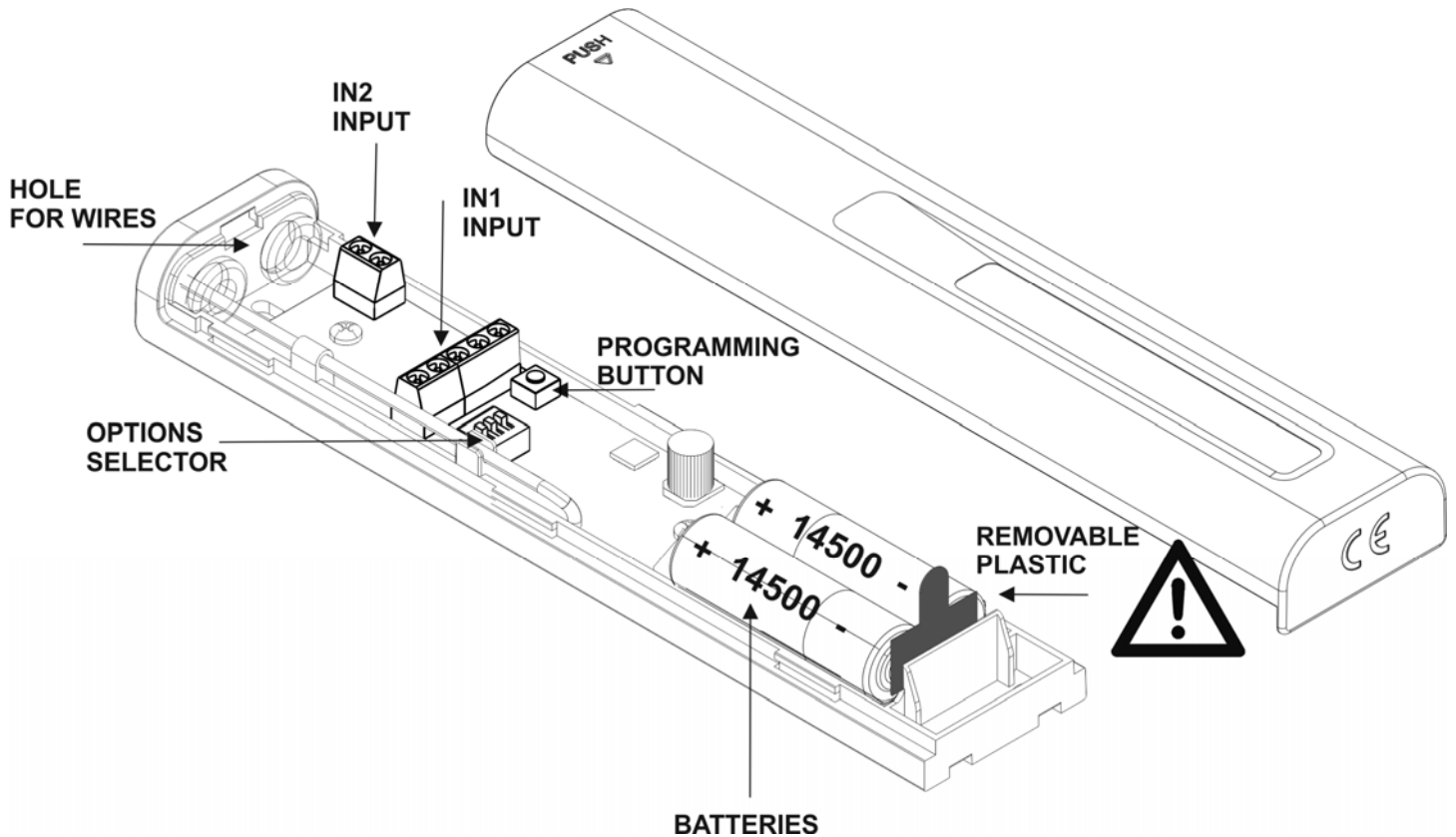

Connection

Option Selector

IN1 CONNECTION	SW1:1	SW1:2
JCM Opto safety edge connection	OFF	OFF
Opto safety edge connection	ON	OFF
8k2 safety edge connection	OFF	ON
NC contact connection	ON	ON

IN2 CONNECTION	SW1:3
NC contact connection	ON
8k2 safety edge connection	OFF

Examples of connection of 8k2safety edges or NC contact

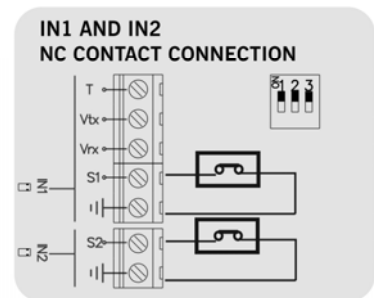
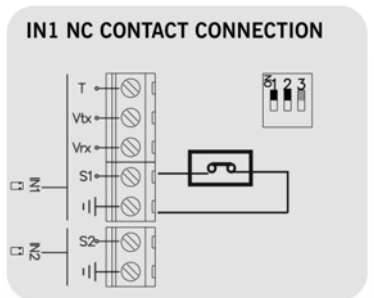
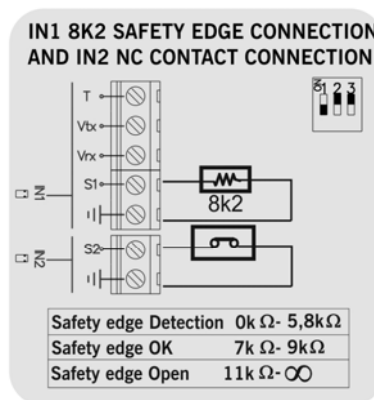
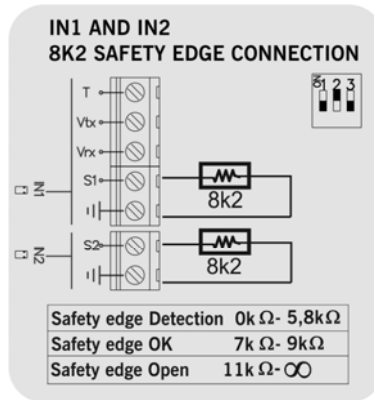
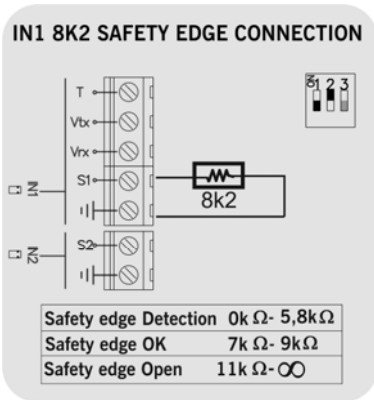

Examples of connection of different types of opto safety edges

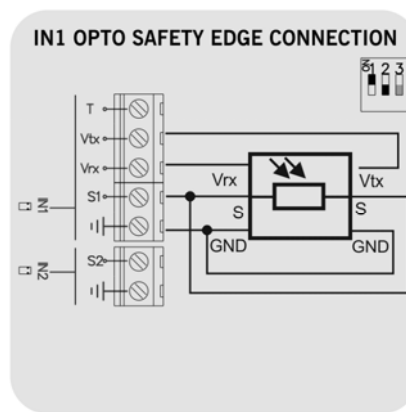
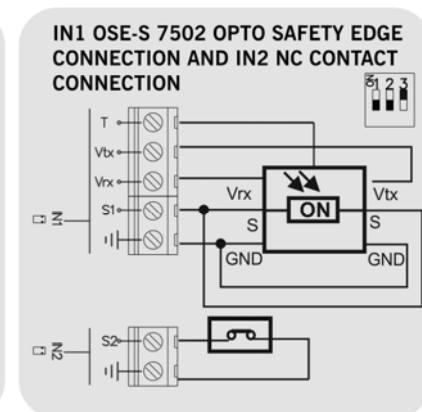
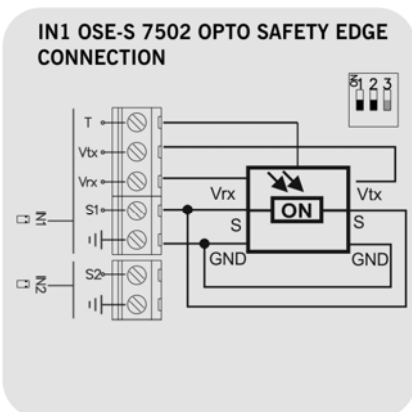

Starting up

Installation

SWIPE TO OPEN COVER



DRILL DOOR

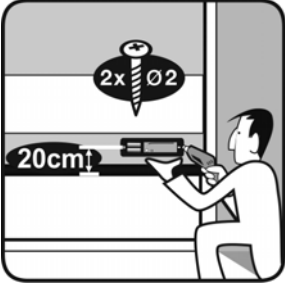

SEE CONNECTION CLAUSE



REMOVE PLASTIC

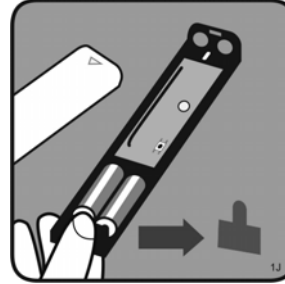

SEE PROGRAMMING CLAUSE



SEE CHECK CLAUSE



SWIPE TO CLOSE COVER

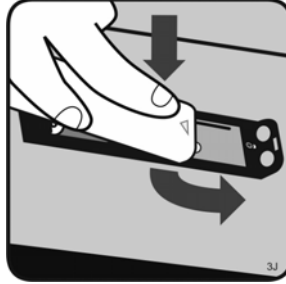

Programming transmitter to receiver

The receiver allows programming 6 transmitters (3 for Relay 1 and 3 for Relay 2). Each safety edge transmitter must be learnt into the appropriate channel of the safety edge receiver. A transmitter should only be connected to one receiver.

Press PROG button and keep pressed until desired mode selected.

Programming of one safety transmitter (IN1 input)

Mode	Configuration of transmitter programming in the receiver.	Led R1	Led R2
1	Safety edge activates relay 1 on the receiver	ON	OFF
2	Safety edge activates relay 2 on the receiver	OFF	ON
3	Safety edge activates the two relays 1 and 2 at the same time	ON	ON

Programming of two safety transmitters (IN1 and IN2 input)

Mode	Configuration of transmitter programming in the receiver.	Led R1	Led R2
4	Safety edge in IN1 activates relay 1 and safety edge in IN2 activates relay 2	Flashing	Flashing

PRESS RPROG PUSHBUTTON

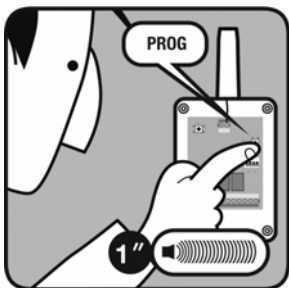

LED TURNS ON

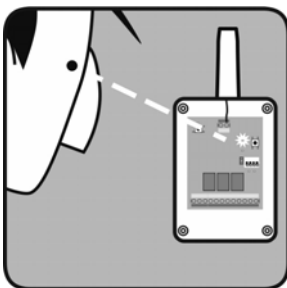

PRESS TRANSMITTER PROG

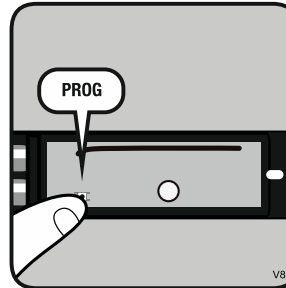

ONE BEEP & PROGRAMMED

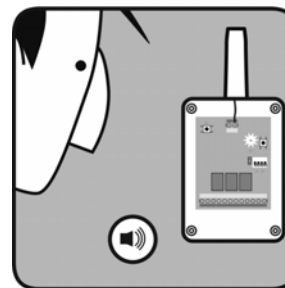

PRESS RPROG PUSHBUTTON



LED TURNS OFF & END PROG

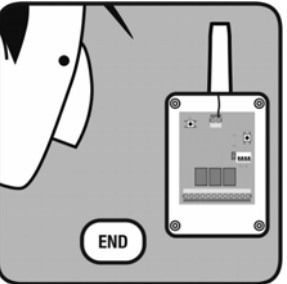

Check the correct operation

Press each safety edge connected to assure that the appropriate relay on the receiver is activated. If not, see the Leds and Beeps indication table, to check what is happening and how to solve it.

Maintenance

Leds and beeps indication table

The status of leds is shown during 5 minutes after pressing PROG button or during the Check function. The rest of the time they are turned off.

IN1 / IN2 Led status	Beeps	Equipment	Message / error	Solution
OFF	No beeps	RB3 transmitter	Safety edge connection and operating correctly	---
ON	No beeps	RB3 transmitter	Safety edge detected	---
Intermittent	No beeps	RB3 transmitter	The safety edge does not operates well (it is not connected or not programmed)	Connect properly or program the safety edge transmitter on the receiver.
OFF	4 beeps every 20 seconds	RB3 receiver	RB3 transmitter low battery	Verify the batteries of the transmitter
ON	No beeps	RB3 receiver	Communication failure between RB3 R and RB3 T	Verify the radio signal with the Check function.

Replacing the transmitter battery

Remove the box cover. Replace the two used batteries with new ones, taking into account the polarity indicated by the connector.

Check that the new batteries support the same temperature range as those they are replacing.

Use of the system

This equipment is designed to be installed with a safety edge for door and gate installations. It is not guaranteed for directly activating equipment other than that specified.

The manufacturer reserves the right to change the specification of the equipment without prior warning.

Important Annex

Disconnect the power supply whenever you proceed to the installation or repair of the control panel.

In accordance with the European low voltage directive, you are informed of the following requirements:

- For permanently connected equipment, an easily accessible connection device must be incorporated into the cabling.
- This system must only be installed by a qualified person that has experience with automatic doors/gates and knowledge of the relevant EU standards.
- The instructions for use of this equipment must always remain in the possession of the user.
- Terminals with a maximum section of 3.8mm² must be used to connect the cables.
- The frequency of the RadioBand system does not interfere in any way with the 868 MHz remote control systems.

JCM TECHNOLOGIES, S.A. declares herewith that the product **RB3 TGL868** complies with the requirements of the 1999/5/ CEE R&TTE Directive, and complies with the fundamental requirements of the 2006/42/CE Machine Directive, 2004/108/EC Directive on electromagnetic compatibility and 2006/95/EC on low voltage, insofar as the product is used correctly.

EC Declaration of conformity

See web www.jcm-tech.com

