

# Nice

## EL-HR40 Battery Replacement Instructions

### ESD Warning

The EL-HR40 can be damaged by electrostatic discharge (ESD). When handling, care must be taken so that the device is not damaged. Damage due to inappropriate handling is not covered by the warranty.

The following precautions should be taken when replacing the battery:

- Use a grounded Anti-Static Wrist Strap
- Always discharge yourself by touching the grounded bare metal surface or approved anti-static mat before picking up an ESD-sensitive electronic component.
- Use an anti-static mat to cover your work surface.

### Required Equipment

- HR40 Remote

- Torx T3 driver

- EL-HR40-BATT HR40 Battery Replacement Kit

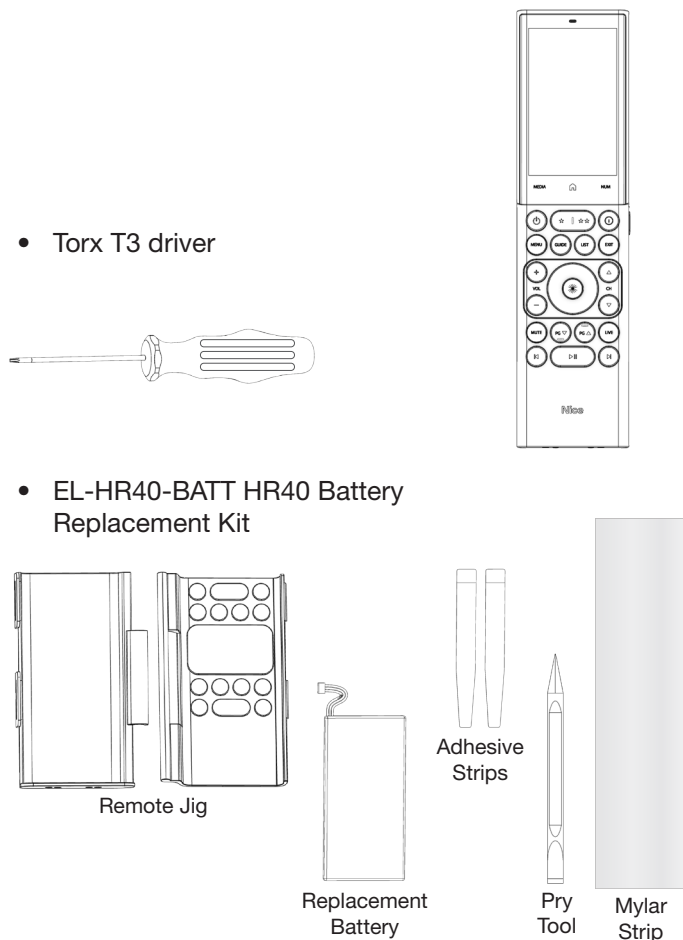

### EL-HR40 Battery Replacement Instructions

1. Remove the screws from the bottom of the remote using a Torx T3 driver.

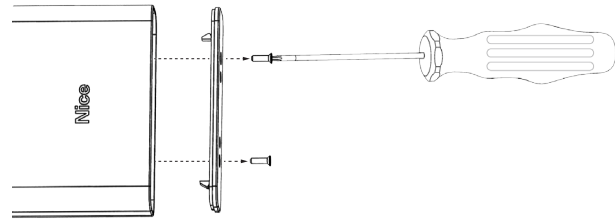

2. Carefully remove the IR lens at the top of the remote using the plastic pry tool.

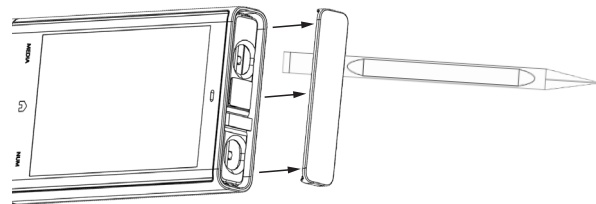

3. Remove the voice command (microphone) button from the side of the remote (pry from the top or bottom).

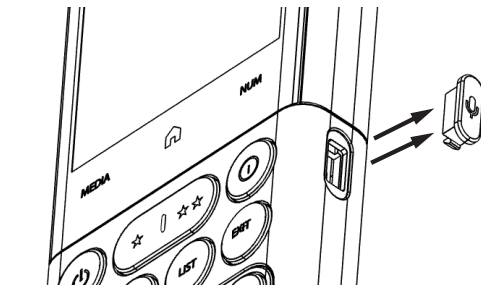

4. Place the remote in the jig and close tightly.

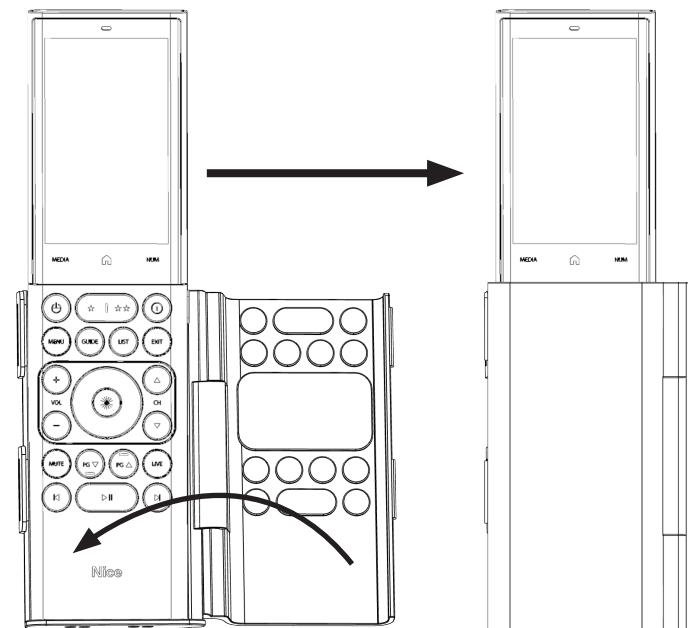

5. Squeezing tightly on the front of the jig (pressing in on the remote buttons), slide the remote upward (while moving the jig downward) to separate the remote from the aluminum body as shown.

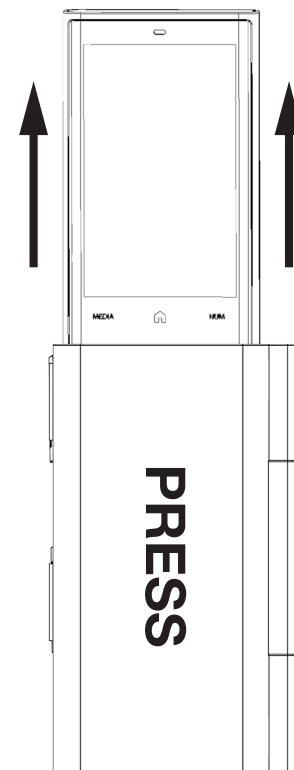

6. Place the remote face down. Pull downward on the black tabs to release the adhesive securing the battery to the remote.

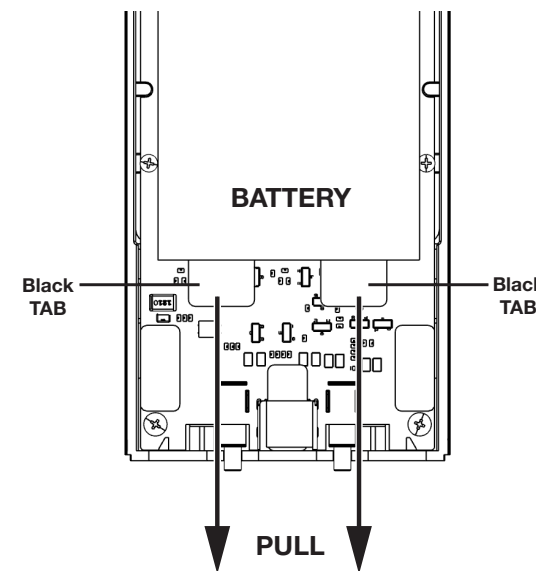

7. Disconnect the battery from the remote terminal by pulling sideways on the connector as shown, taking care with other wires and components. Do not pull on the battery lead. If the connector seems stuck, wriggle it side to side to loosen.

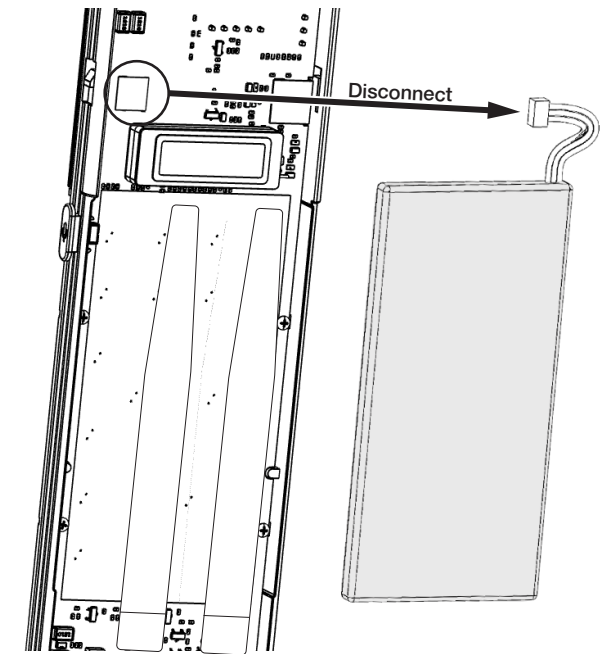

8. Remove the backing on the provided adhesive strips with the blue side up, and place on the remote where indicated. Remove the blue backing on the adhesive strips to expose the adhesive side.

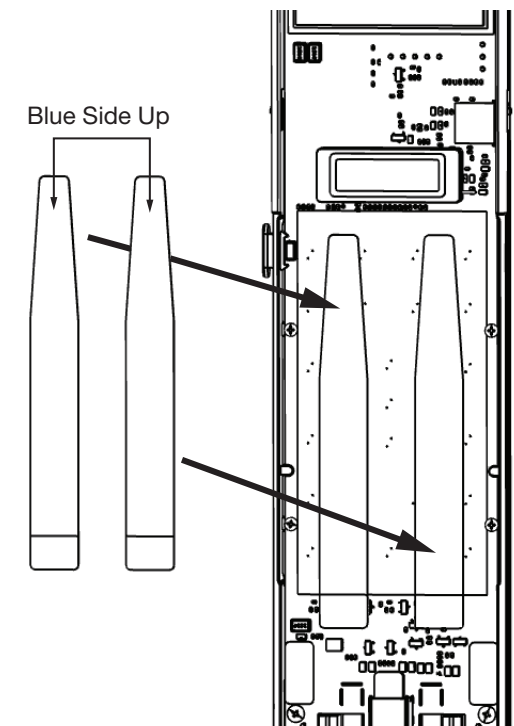

9. Place the new battery on the adhesive strips with the lead on the right side, and reconnect the terminal.

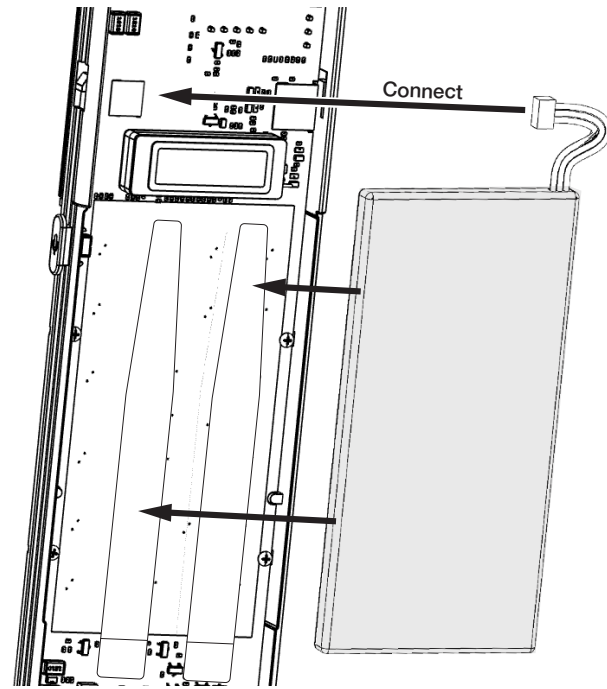

10. Place the remote on its back, and place the mylar strip over the face of the remote. Slide the aluminum body over the bottom section of the remote as shown.

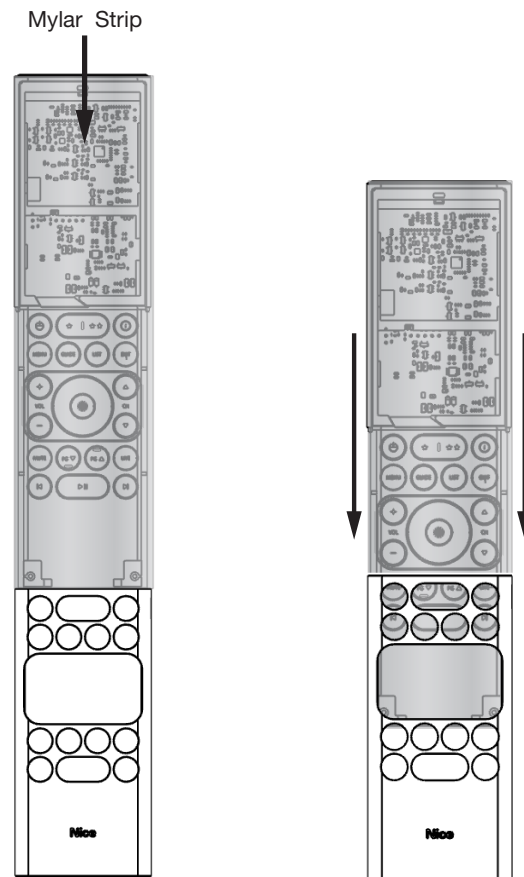

11. Making sure the body slides over the mylar strip, slide the remote into the aluminum base.

Once the buttons line up with the holes in the aluminum body, slide the mylar strip out.

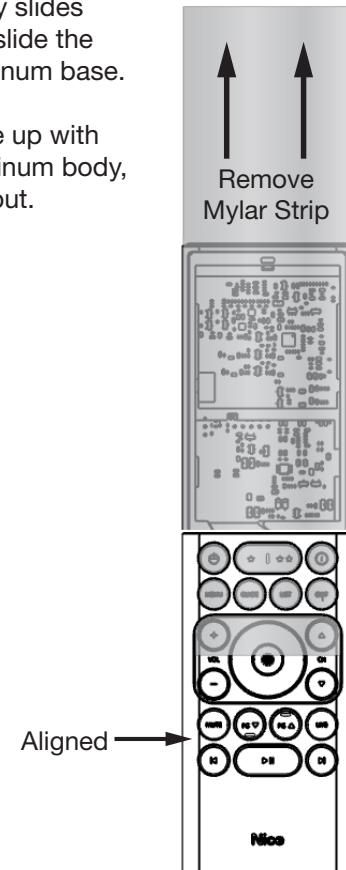

12. Place the remote face down and slide the upper plastic section over the top half of the remote, and slide it down until the lip on the plastic slides under the aluminum body.

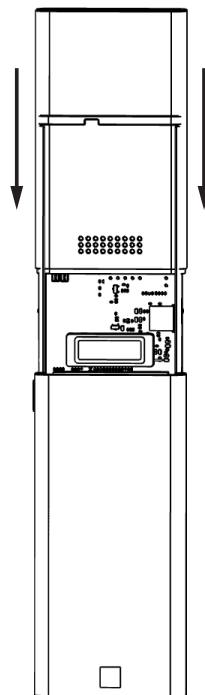

13. Replace the microphone button and IR lens, and then reattach the bottom cap with the two Torx screws.

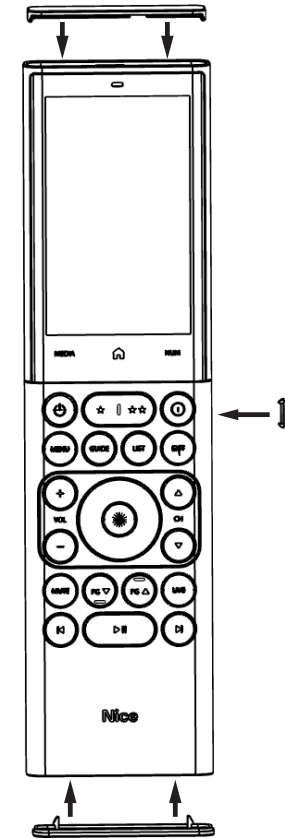

**NOTE:** The IR window and bottom cap can only be inserted one way.

14. Press and hold the power button until the Nice logo appears. The remote will restart.

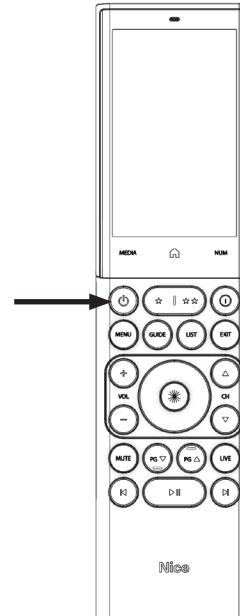

### Limited Warranty

Nice warrants the EL-HR40 to be free from defects in materials and workmanship for the period of two years (2 years) from the date of purchase. If within the applicable warranty period above purchaser discovers that such item was not as warranted above and promptly notifies Nice in writing, Nice shall repair or replace the item at the company's option.

This warranty shall not apply (a) to equipment not manufactured by Nice, (b) to equipment which shall have been installed by other than an Nice authorized installer, (c) to installed equipment which is not installed to Nice's specifications, (d) to equipment which shall have been repaired or altered by others than Nice, (e) to equipment which shall have been subjected to negligence, accident, or damage by circumstances beyond Nice's control, including, but not limited to, lightning, flood, electrical surge, tornado, earthquake, or other catastrophic events beyond Nice's control, or to improper operation, maintenance or storage, or to other than normal use of service. With respect to equipment sold by, but not manufactured by Nice, the warranty obligations of Nice shall in all respects conform to the warranty actually extended to Nice by its supplier. The foregoing warranties do not cover reimbursement for labor, transportation, removal, installation or other expenses which may be incurred in connection with repair or replacement.

Except as may be expressly provided and authorized in writing by Nice, Nice shall not be subject to any other obligations or liabilities whatsoever with respect to equipment manufactured by Nice or services rendered by Nice.

THE FOREGOING WARRANTIES ARE EXCLUSIVE AND IN LIEU OF ALL OTHER EXPRESSED AND IMPLIED WARRANTIES EXCEPT WARRANTIES OF TITLE, INCLUDING BUT NOT LIMITED TO IMPLIED WARRANTIES OF MERCHANTABILITY AND FITNESS FOR A PARTICULAR PURPOSE.

ATTENTION: TO OUR VALUED CUSTOMERS: To ensure that customers obtain quality, pre-sale and after-sale support and service, Nice North America products are sold exclusively through authorized dealers.

Nice products are not sold online. The warranties on Nice products are NOT VALID if the products have been purchased from an unauthorized dealer or an online reseller.

To determine if your Nice reseller is authorized, please call Nice at +1-800-421-1587.



**Technical Support:**  
800-421-1587

**Technical Support Hours:**  
Monday – Friday, 6am – 4pm PST

**Nice North America**  
c/o Customer Service  
5919 Sea Otter Place, Suite 100  
Carlsbad, CA 92010

**Nice**

**Niceforyou.com**

©2023 Nice North America LLC.  
All rights reserved.