



Ditec NEOS

Sliding Gates

(Original instructions)

IP2160 EN
Technical Manual

Index

Subject		Page
1.	General safety precautions	4
2.	Declaration of incorporation of partly completed machinery	5
2.1	Machine Directive	5
3	Technical specifications	6
3.1	Operating instructions	6
4.	Standard installation	7
5.	Dimensions	8
6.	Main components	8
7.	Installation	9
7.1	Preliminary checks	9
7.2	Base plate position	10
7.3	Gearmotor installation	11
7.4	Rack installation	12
7.5	Operation with encoder	13
7.6	Magnetic limit switch installation and adjustment	13
7.7	Chain drive kit installation	14
8.	Electrical connections	15
9.	Routine maintenance plan	16
	Operating instructions	17

Key



This symbol indicates instructions or notes regarding safety, to which special attention must be paid.



This symbol indicates useful information for the correct functioning of the product.

1. General safety precautions



Failure to observe the information in this manual may result in minor personal injury or damage to equipment.
Save these instructions for future reference.

This installation manual is intended for qualified personnel only. Installation, electrical connections and adjustments must be performed in accordance with Good Working Methods and in compliance with the present standards. Read the instructions carefully before installing the product.

Bad installation could be dangerous.



The packaging materials (plastic, polystyrene, etc.) should not be discarded in the environment or left within reach of children, as these are a potential source of danger.

Before installing the product, make sure it is in perfect condition.

Do not install the product in explosive areas and atmospheres: the presence of inflammable gas or fumes represents a serious safety hazard.

Before installing the motorisation device, make all the necessary structural modifications in order to create safety clearance and to guard or isolate all the crushing, shearing, trapping and general hazardous areas.

Make sure the existing structure is up to standard in terms of strength and stability. The motorisation device manufacturer is not responsible for failure to observe Good Working Methods when building the frames to be motorised or for any deformation during use.

The safety devices (photocells, safety edges, emergency stops, etc.) must be installed taking into account: applicable laws and directives, Good Working Methods, installation premises, system operating logic and the forces developed by the motorised door.

The safety devices must protect the crushing, cutting, trapping and general hazardous areas of the motorised door.

Display the signs required by law to identify hazardous areas.



Each installation must bear a visible indication of the data identifying the motorised door.

When requested, connect the motorised door to an effective earthing system that complies with current safety standards.

During installation, maintenance and repair operations, cut off the power supply before opening the cover to access the electrical parts.

The automation protection casing must be removed by qualified personnel only.



The electronic parts must be handled using earthed antistatic conductive arms. The manufacturer of the motorisation declines all responsibility in the event of component parts being fitted that are not compatible with the safe and correct operation.

Use original spare parts only for repairs or replacements of products.

The installer must supply all information on automatic, manual and emergency operation of the motorised door and must provide the user with the operating instructions.

2. Declaration of incorporation of partly completed machinery

(Directive 2006/42/EC, Annex II-B)

The manufacturer Entrematic Group AB with headquarters in Lodjursgatan 10, SE-261 44 Landskrona, Sweden, declares that the automation for Ditec NEOS type sliding gate:

- has been constructed to be installed on a manual door to construct a machine pursuant to the Directive 2006/42/EC. The manufacturer of the motorised door shall declare conformity pursuant to the Directive 2006/42/EC (Annex II-A), prior to the machine being put into service;
- conforms to the applicable essential safety requirements indicated in ANNEX I, Chapter 1 of the Directive 2006/42/EC;
- conforms to the Low Voltage Directive 2006/95/EC;
- conforms to the Electromagnetic Compatibility Directive 2004/108/EC;
- the technical documentation conforms to Annex VII-B of the Directive 2006/42/EC;
- the technical documentation is managed by Marco Pietro Zini with headquarters in Via Mons. Banfi, 3 - 21042 Caronno Pertusella (VA) - ITALY;
- a copy of technical documentation will be provided to national competent authorities, following a suitably justified request.

Landskrona, 08-03-2013

Marco Pietro Zini
(BA President)

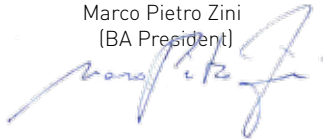

2.1 Machinery Directive

Pursuant to Machinery Directive (2006/42/EC) the installer who motorises a door or gate has the same obligations as the manufacturer of machinery and as such must:

- prepare the technical file which must contain the documents indicated in Annex V of the Machinery Directive;
(The technical file must be kept and placed at the disposal of competent national authorities for at least ten years from the date of manufacture of the motorised door);
- draw up the EC Declaration of Conformity in accordance with Annex II-A of the Machinery Directive and deliver it to the customer;
- affix the EC marking on the motorised door in accordance with point 1.7.3 of Annex I of the Machine Directive.

3. Technical specifications

	Ditec NES300EH	Ditec NES300EHP	Ditec NES400EH	Ditec NES400EHP
Power supply	230 V~ 50/60Hz	230 V~ 50/60Hz	230 V~ 50/60Hz	230 V~ 50/60Hz
Absorption	1,2 A	1,2 A	1,2 A	1,2 A
Line fuse	F1,6 A	F1,6 A	F1,6 A	F1,6 A
Thrust	300 N	300 N	400 N	400 N
Wing speed	0,1±0,25 m/s	0,1±0,25 m/s	0,1±0,25 m/s	0,1±0,25 m/s
Maximum stroke	12 m	12 m	12 m	12 m
Maximum wing weight	300 kg	300 kg	400 kg	400 kg
Service class	4 - INTENSE	4 - INTENSE	4 - INTENSE	4 - INTENSE
Intermittence	S2 = 30 min S3 = 50%	S2 = 30 min S3 = 50%	S2 = 30 min S3 = 50%	S2 = 30 min S3 = 50%
Temperature	-20° C - +55° C	-20° C - +55° C	-20° C - +55° C	-20° C - +55° C
Degree of protection	IP24	IP24	IP24	IP24
Control panel	CS12E	CS12M	CS12E	CS12M

	Ditec NES600EH	Ditec NES600EHP	Ditec NES1000EHP
Power supply	230 V~ 50/60Hz	230 V~ 50/60Hz	230 V~ 50/60Hz
Absorption	1,5 A	1,5 A	2 A
Line fuse	F2A	F2A	F2,5 A
Thrust	600 N	600 N	1000 N
Wing speed	0,1±0,24 m/s	0,1±0,24 m/s	0,1±0,19 m/s
Maximum stroke	20 m	20 m	20 m
Maximum wing weight	600 kg	600 kg	1000 kg
Service class	4 - INTENSE	4 - INTENSE	4 - INTENSE
Intermittence	S2 = 30 min S3 = 50%	S2 = 30 min S3 = 50%	S2 = 30 min S3 = 50%
Temperature	-20° C - +55° C	-20° C - +55° C	-20° C - +55° C
Degree of protection	IP24	IP24	IP24
Control panel	CS12E	CS12M	CS12M

3.1 Operating instructions

Service class: 4 (minimum 10±5 years of working life with 100±200 cycles per day).

Applications: INTENSE (for apartment block, industrial and commercial entrances and car parks with vehicle access or access for intense pedestrian use).

- Performance characteristics are to be understood as referring to the recommended weight (approx. 2/3 of maximum permissible weight). When used with the maximum permissible weight a reduction in the above mentioned performance can be expected.
- Service class, running times, and the number of consecutive cycles are to be taken as merely indicative, having been statistically determined under average operating conditions, and are therefore not necessarily applicable to specific conditions of use.
- Each automatic entrance has variable elements such as: friction, balancing and environmental factors, all of which may substantially alter the performance characteristics of the automatic entrance or curtail its working life or parts thereof (including the automatic devices themselves). The installer should adopt suitable safety conditions for each particular installation.

4. Standard installation

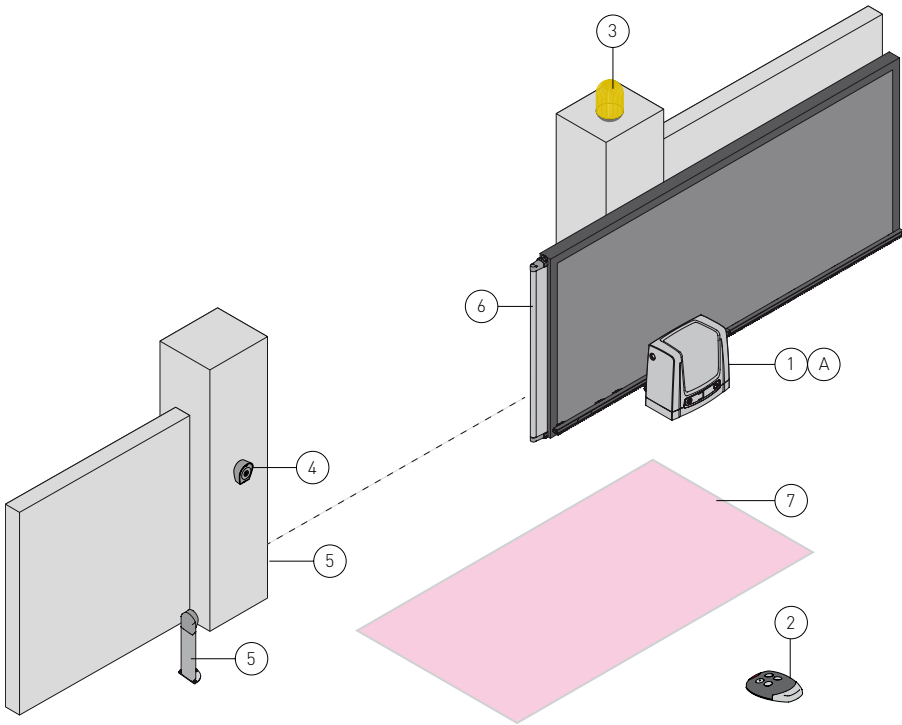

Ref.	Code	Description
1	NES300 NES400 NES600 NES1000	300 kg gearmotor with control panel 400 kg gearmotor with control panel 600 kg gearmotor with control panel 1000 kg gearmotor with control panel
2	GOL4 GOL4C	Remote control
3	LAMPH	Flashing light
4	XEL5 LAN4 GOL4M	Key selector switch Keypad Wireless keypad
5	XEL2 LAB4	Photocells IP55 photocells
6	SOFA-SOFB GOPAV	Safety edge Radio system for safety edges
7	LAB9	Magnetic loop detector for passage control
A		Connect the power supply to a type-approved omnipolar switch, with a contact opening distance of at least 3 mm (not supplied). Connection to the mains must be via independent channels and separate from the connections to the control and safety devices.

5. Dimensions

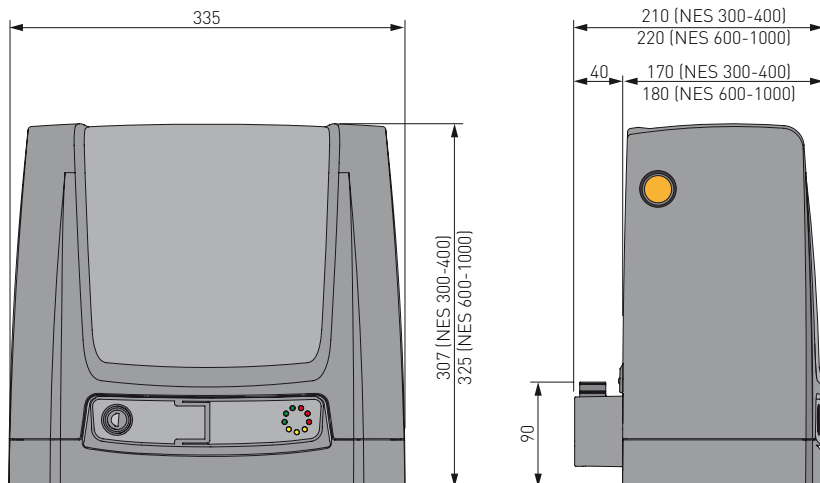

6. Main components

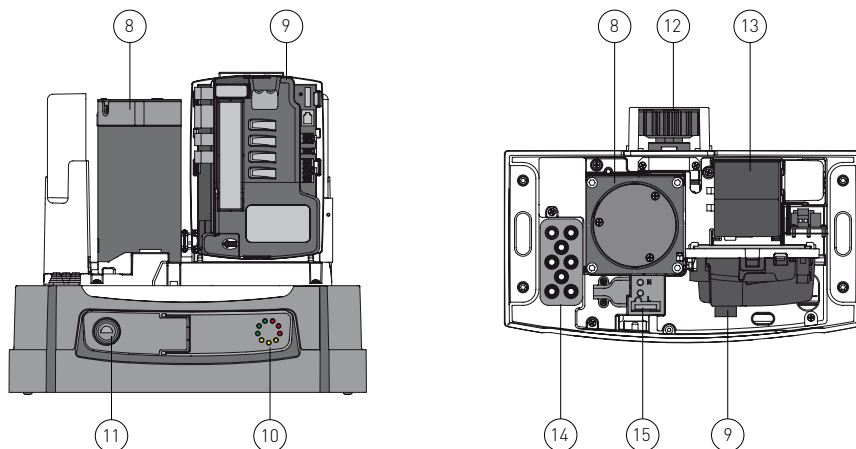

Ref.	Code	Description
8		Motor
9		Control panel
10		Diagnostic circuit
11		Key release
12		Pinion
13		Battery kit
14		Cable inlet
15		Power supply terminal

7. Installation

The given operating and performance features can only be guaranteed with the use of DITEC accessories and safety devices.

Unless otherwise specified, all measurements are expressed in mm.

7.1 Preliminary checks

Check the stability of the wing (derailing and lateral falls) and the sliding wheels and that the upper guides do not cause any friction.

The sliding guide must be securely fixed to the ground for the full length within doorway and must have no irregularities that could hinder the movement of the wing.

The opening and closing stops must be fitted.

If the gate has slits, make sure they are covered to prevent shearing points or install active safety edges on the columns.

Safety device should be installed at the end of the wing to reduce the collision force.



N.B.: make sure that the gate can not exit the sliding guides and fall.

7.2 Base plate position

- [1] Insert the anchor ties into the base plate and fix them with the supplied nuts.
 - [2] Insert the screws in the base plate, secure them with the nuts and then bend the metal tab to prevent the screw from coming out.
 - Extract the preformed ties with a downwards movement using a hammer to ensure correct anchorage to the concrete.
- Make a concrete base with the anchor ties and base plate embedded, which must be level and clean and of the size indicated in the figure.

i N.B.: if the concrete base has already been made, base plate [2] can be fixed using M8 plugs (not supplied).

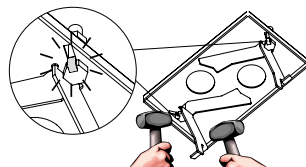
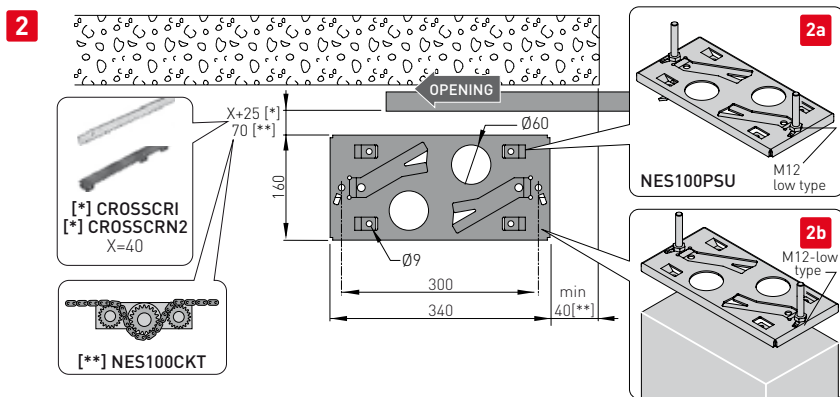
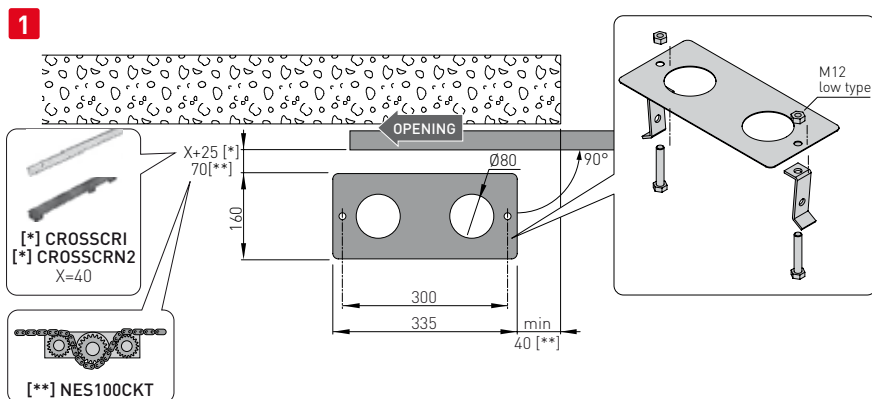

7.3 Gearmotor installation

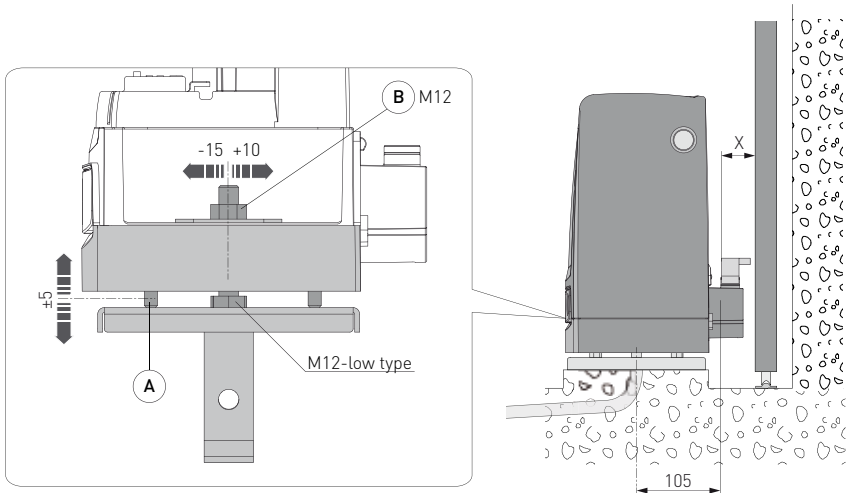
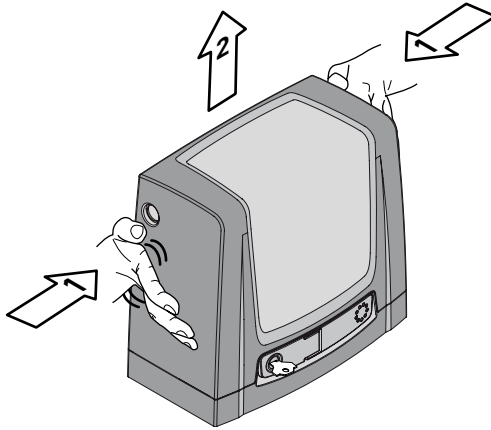

- Release the gearmotor (see OPERATING INSTRUCTIONS). Unscrew the front screw and remove the casing by pressing on the side.
- Place the gearmotor on the base plate.
- Adjust the gearmotor horizontally by sliding it along the slots of the gearmotor base and vertically with four levelling screws [A].
N.B.: during the vertical adjustment, keep the gearmotor slightly raised from the base plate so that the rack can be fixed and subsequent adjustments are possible.
- After adjusting, fix the gearmotor using screws [B].



WARNING: The gearmotor must be suitably raised from the ground to avoid flooding.

7.4 Rack installation

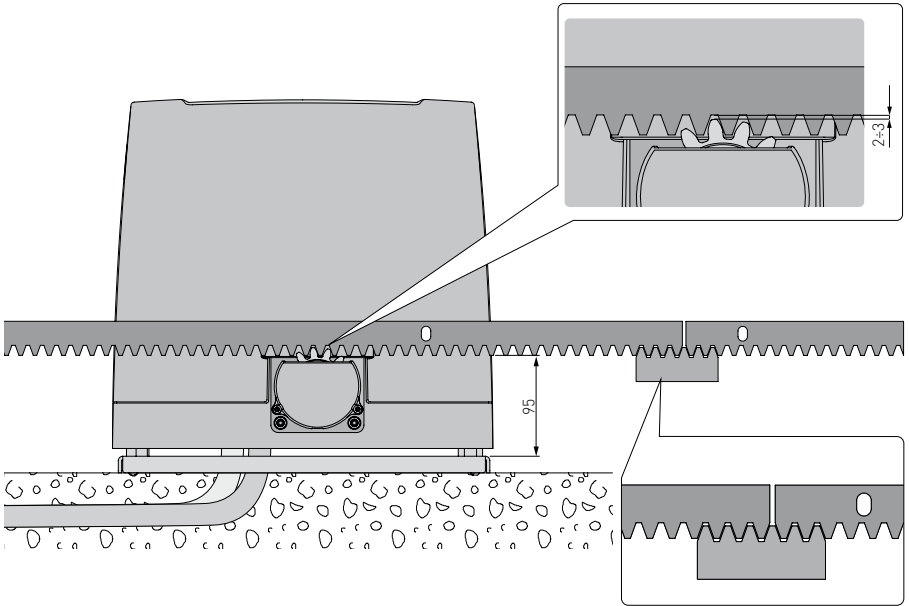

- Release the gearmotor (see OPERATING INSTRUCTIONS) and open the gate.
- Place the rack against the pinion and sliding the gate manually fix it along its whole length.
N.B.: To make it easier to align the rods correctly, use a scrap piece of rack and rest it underneath the junction point, as shown in the figure detail.
- Once fixed, vertically adjust the gearmotor to give a play of about 2 to 3 mm between the pinion and the rack.
- Secure the gearmotor.
- Slightly lubricate the rack and pinion after assembly.
Manually check that the gate slides evenly and without friction.

7.5 Operation with encoder

NEOS gearmotors do not require limit switches because they have encoders. Mechanical opening and closing end stops must be installed.

The gate automatically slows when approaching the end stops.

WARNING: when the gate reaches the opening or closing limit stop, it reverses briefly to facilitate manual release of the gearmotor.

7.6 Magnetic limit switch installation and adjustment

- Manually place the wing in the open position and fix limit switch brackets [A] and [B] on rack [C]. Repeat this operation with the wing in the closed position.
- After a few manoeuvres, adjust the position of limit switch brackets [A] and [B] so that the gate stops about 20 mm before reaching the opening and closing mechanical stops.



The limit switch kit is optional and is used to stop the gate before it reaches the opening and closing mechanical stops. With a limit switch installed, slowdown is carried out at regulated power to overcome possible friction.

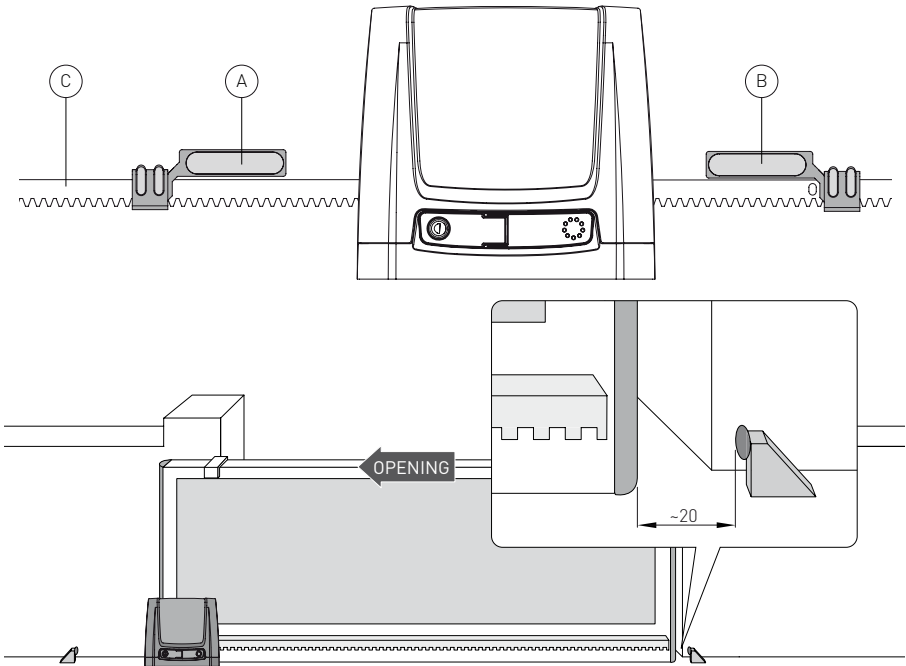

7.7 Chain drive kit installation

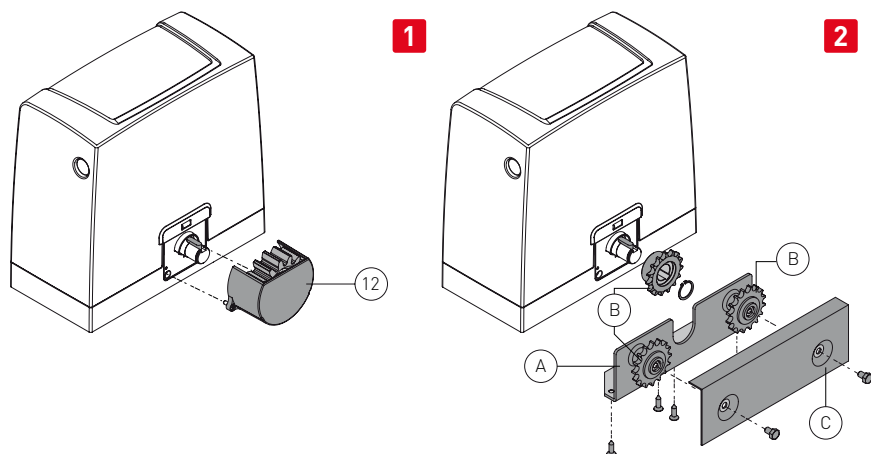

N.B.: Install the chain drive kit before securing the gearmotor to the base plate.

- Release the gearmotor (see OPERATING INSTRUCTIONS).
- [1] Remove pinion [12].
- [2] Fix pinion supporting plate [A] to the gearmotor.
- Insert pinions [B] as illustrated in the diagram.
- [3] Pass the chain between the pinions by hand.
- Fix cover plate [C].

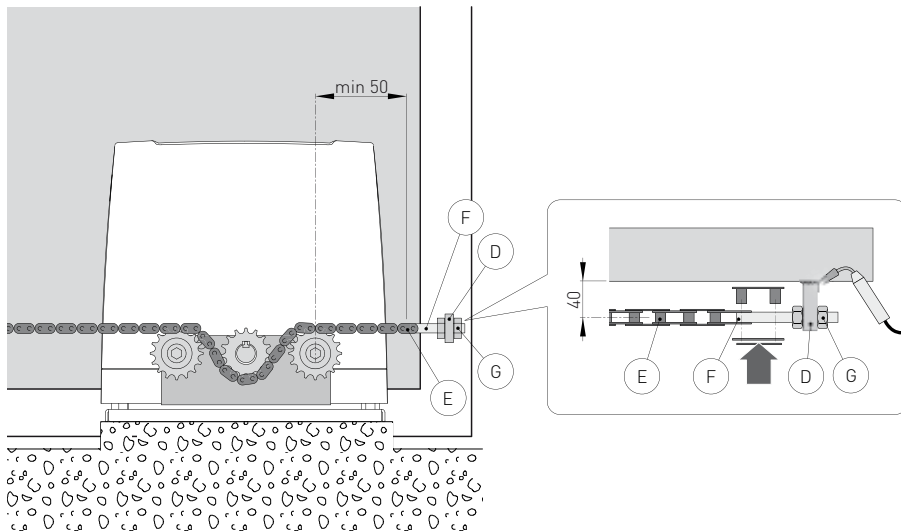

- Move the wing into the open position by hand and fix brackets [D] on the wing as illustrated in the diagram.
- Connect chain [E], which was previously assembled on the gearmotor, to tie rod [F] and fix it to bracket [D].
- Fix bracket [D] on the opposite side of the gate. Connect chain [E] to tie rod [F] and fix it to bracket [D] (cut the excess chain).
N.B.: Make sure that the distance between the pinion centre and tie rod [F] is correct when the gate is fully open and closed.
- Secure the chain with nuts [G].
- Tighten the chain [E] with the tie rods [F].
- Slightly lubricate the chain [E] and the pinions after assembly.

8. Electrical connections

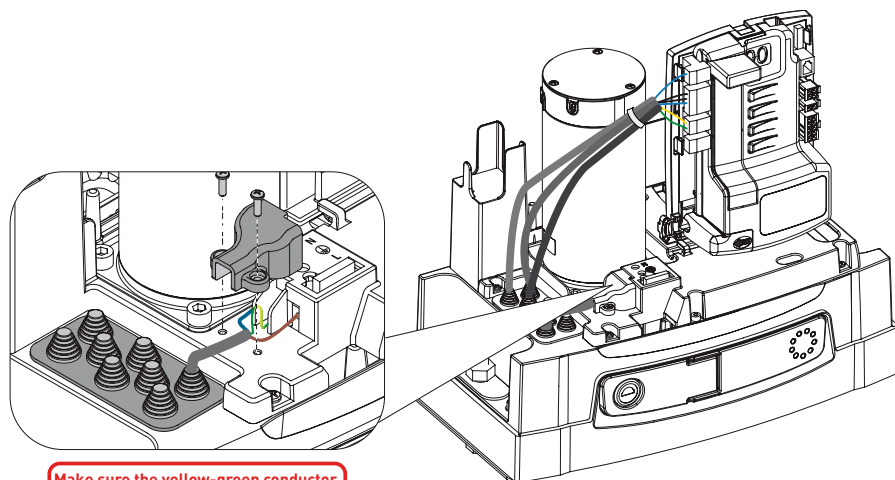

Make sure the yellow-green conductor is at least 30 mm longer than the brown and blue conductors



Before connecting the power supply, make sure the plate data correspond to that of the mains power supply.

An omnipolar disconnection switch with minimum contact gaps of 3 mm must be included in the mains supply.

Check that upstream of the electrical installation there is an adequate residual current circuit breaker and a suitable overcurrent cutout.

Use a H05RN-F 3G1.5 or H05RR-F 3G1.5 type electric cable and connect it to terminals L (brown), N (blue), \perp (yellow/green) inside the automation.

Secure the cable using a special cable clamp and remove the sheath only where the clamp is. Connection to the mains power supply, in the section outside the automation, is made with independent channels and separated from the connections to the control and safety devices. The channel must penetrate the automation through the holes on the base plate by a few centimetres.

Make sure there are no sharp edges that may damage the power supply cable.

Make sure the mains power conductors (230 V) and accessory power conductors (24 V) are separated.

The cables must be double insulated. Remove the sheath near the connecting terminals and secure them with cable clamps.



9. Routine maintenance plan

Perform the following operations and checks every 6 months according to intensity of use of the automation.

Disconnect the 230 V~ power supply and batteries (if fitted) and release the gearmotor:

- Visually check that the gate, the fixing brackets and existing structure have suitable mechanical strength and are in good condition.
- Check the gate-gearmotor alignment, the distance (2-3 mm) between the groove of the pinion and the crest of the rack.
- Clean the wheel's sliding guide, the rack and pinion of the gearmotor and slightly lubricate the rack and pinion. Manually check that the gate slides evenly and without friction.

Connect the 230 V~ power supply and batteries (if fitted) and lock the gearmotor:

- Make sure the limit switches are working correctly.
- Check the power adjustment.
- Check that all control and safety functions are working correctly.





N.B.: For spare parts, see the spares price list.

Operating instructions

General safety precautions

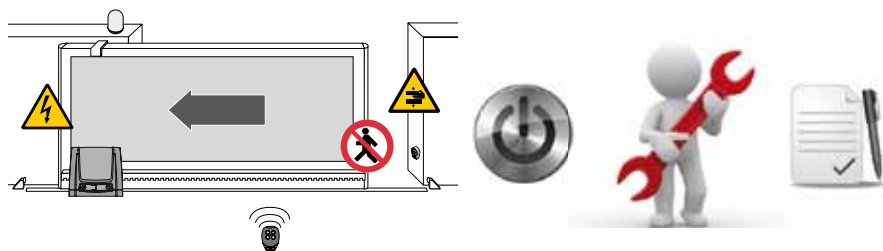
Ditec
ENTREMATIc



 These precautions are an integral and essential part of the product and must be supplied to the user.

Read them carefully since they contain important information on safe installation, use and maintenance.

These instructions must be kept and forwarded to all possible future users of the system.

This product must only be used for the specific purpose for which it was designed.

Any other use is to be considered improper and therefore dangerous. The manufacturer cannot be held responsible for any damage caused by improper, incorrect or unreasonable use.

This product must not be used by people (including children) with reduced physical, sensorial or mental abilities, or lack of experience or knowledge, unless they are given proper surveillance and instructions for operating the device by a person responsible for their safety.

Avoid operating in the proximity of the hinges or moving mechanical parts.

Do not enter within the operating range of the motorised door while it is moving.

Do not block the movement of the motorised door since this may be dangerous.

Do not allow children to play or stay within the operating range of the motorised door.

Keep remote controls and/or any other control devices out of the reach of children in order to avoid possible involuntary activation of the motorised door.

In the event of a fault or a malfunction of the product, turn off the power supply switch, do not attempt to repair or intervene directly and contact only qualified personnel.

Failure to comply with the above may cause a dangerous situation.

All cleaning, maintenance or repair work must be carried out by qualified personnel.

To ensure that the system works efficiently and correctly, the manufacturer's indications must be complied with and only qualified personnel must see to the routine maintenance of the motorised gate.

In particular, regular checks are recommended in order to verify that the safety devices are operating correctly.

All installation, maintenance and repair work must be documented and made available to the user.

 To dispose of electrical and electronic equipment as well as batteries correctly, users must take them to special "recycling centres" provided by the municipal authorities.

Manual release instructions

In the event of a fault or power failure, insert the key and turn it clockwise and completely open the panel. Manually open the gate.

To lock the gate again, close the hatch, turn the key anticlockwise and remove the key.

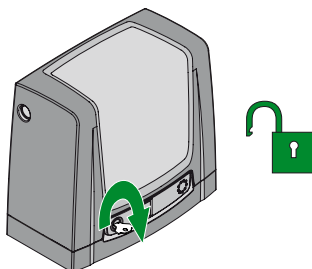
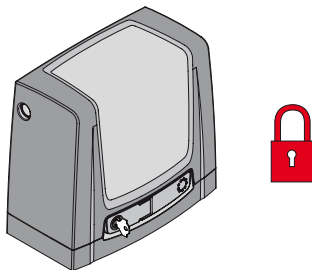

WARNING: carry out the wing blocking and release with the motor switched off. Do not enter within the operating range of the wing.



When the panel is closed but the key is still horizontal, the release microswitch is open and all manoeuvres are prevented.



For any problems and/or information, contact the support service.

Installer's stamp	Operator
	Date of intervention
	Technician's signature
	Customer's signature

Intervention performed _____

Entrematic Group AB
 Lodjursgatan 10
 SE-261 44, Landskrona
 Sweden
 www.ditecentrematic.com

DETACH AND DELIVER TO THE CUSTOMER

IP2160EN - 2013-10-31

All the rights concerning this material are the exclusive property of Entrematic Group AB.

Although the contents of this publication have been drawn up with the greatest care, Entrematic Group AB cannot be held responsible in any way for any damage caused by mistakes or omissions in this publication. We reserve the right to make changes without prior notice.

Copying, scanning and changing in any way are expressly forbidden unless authorised in writing by Entrematic Group AB.

Entrematic Group AB
Lodjursgatan 10
SE-261 44, Landskrona
Sweden
www.ditecentrematic.com

Ditec

ENTRE//MATIC

