

- I** QUADRO COMANDO
- GB** CONTROL PANEL
- F** CENTRALE DE COMMANDE
- D** SELBSTÜBERWACHENDE STEUERUNG
- E** CUADRO DE MANDOS
- P** QUADRO DE COMANDO

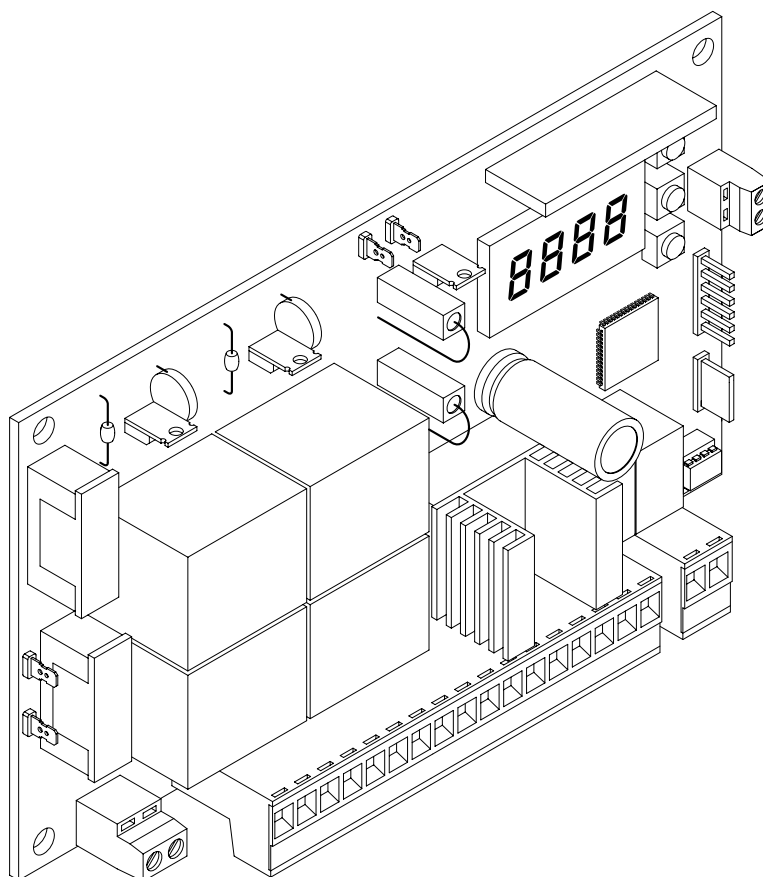

LIBRA-MA-R



ISTRUZIONI D'USO E DI INSTALLAZIONE
INSTALLATION AND USER'S MANUAL
INSTRUCTIONS D'UTILISATION ET D'INSTALLATION
INSTALLATIONS-UND GEBRAUCHSANLEITUNG
INSTRUCCIONES DE USO Y DE INSTALACION
INSTRUÇÕES DE USO E DE INSTALAÇÃO



**AZIENDA CON SISTEMA
 DI GESTIONE INTEGRATO
 CERTIFICATO DA DNV
 = UNI EN ISO 9001:2000 =
 UNI EN ISO 14001:1996**

Via Lago di Vico, 44
 36015 Schio (VI)
 Tel.naz. 0445 696511
 Tel.int. +39 0445 696533
 Fax 0445 696522
 Internet: www.bft.it
 E-mail: sales@bft.it



Thank you for buying this product, our company is sure that you will be more than satisfied with its performance.

This product is supplied with an "Instruction Manual" which should be read carefully as it provides important information about safety, installation, operation and maintenance.

This product complies with recognised technical standards and safety regulations. We declare that it is in conformity with the following European Directives: 89/336/EEC, 73/23/EEC, 98/37/EEC and subsequent amendments.

1) GENERAL SAFETY

WARNING! An incorrect installation or improper use of the product can cause damage to persons, animals or things.

WARNING! Installation must be carried out using the safety devices and controls prescribed by the EN 12978 Standard.

- The "Warnings" leaflet and "Instruction booklet" supplied with this product should be read carefully as they provide important information about safety, installation, use and maintenance.
- Scrap packing materials (plastic, cardboard, polystyrene etc) according to the provisions set out by current standards. Keep nylon or polystyrene bags out of children's reach.
- Keep the instructions together with the technical brochure for future reference.
- This product was exclusively designed and manufactured for the use specified in the present documentation. Any other use not specified in this documentation could damage the product and be dangerous.
- The Company declines all responsibility for any consequences resulting from improper use of the product, or use which is different from that expected and specified in the present documentation.
- Do not install the product in explosive atmosphere.
- The construction components of this product must comply with the following European Directives: 89/336/CEE, 73/23/EEC, 98/37/EEC and subsequent amendments. As for all non-EEC countries, the above-mentioned standards as well as the current national standards should be respected in order to achieve a good safety level.
- The Company declines all responsibility for any consequences resulting from failure to observe Good Technical Practice when constructing closing structures (door, gates etc.), as well as from any deformation which might occur during use.
- The installation must comply with the provisions set out by the following European Directives: 89/336/CEE, 73/23/EEC, 98/37/EEC and subsequent amendments.
- Disconnect the electrical power supply before carrying out any work on the installation. Also disconnect any buffer batteries, if fitted.
- Fit an omnipolar or magnetothermal switch on the mains power supply, having a contact opening distance equal to or greater than 3,5 mm.
- Check that a differential switch with a 0.03A threshold is fitted just before the power supply mains.
- Check that earthing is carried out correctly: connect all metal parts for closure (doors, gates etc.) and all system components provided with an earth terminal.
- Fit all the safety devices (photocells, electric edges etc.) which are needed to protect the area from any danger caused by squashing, conveying and shearing.
- Position at least one luminous signal indication device (blinker) where it can be easily seen, and fix a Warning sign to the structure.
- The Company declines all responsibility with respect to the automation safety and correct operation when other manufacturers' components are used.
- Only use original parts for any maintenance or repair operation.
- Do not modify the automation components, unless explicitly authorised by the company.
- Instruct the product user about the control systems provided and the manual opening operation in case of emergency.
- Do not allow persons or children to remain in the automation operation area.
- Keep radio control or other control devices out of children's reach, in order to avoid unintentional automation activation.
- The user must avoid any attempt to carry out work or repair on the automation system, and always request the assistance of qualified personnel.
- Anything which is not expressly provided for in the present instructions, is not allowed.
- Installation must be carried out using the safety devices and controls prescribed by the EN 12978 Standard.

2) GENERAL OUTLINE

The LIBRA-MA-R control panel is supplied by the manufacturer with standard setting. Any alteration must be set by means of the incorporated display programmer or by means of UNIPRO. The Control unit completely

supports the EELINK protocol.

Its main characteristics are:

- Control of two low-voltage motors up to 40W power
- Electronic torque setting with obstacle detection
- Limit-switch control inputs
- Separate inputs for safety devices
- Incorporated rolling-code radio receiver with transmitter cloning

The board is provided with a terminal board which can be pulled out for easier maintenance or replacement. The board is supplied with a series of pre-wired jumpers to facilitate the installer's work.

The jumpers relate to the following terminals: 15-17 and 15-18. If the above-mentioned terminals are in use, remove their respective jumpers.

CHECK

The LIBRA MA-R panel carries out a control (check) on the starting relays and safety devices (photocells, safety edge etc.) before carrying out each opening and closing cycle.

In case of malfunction, check the devices connected for regular operation (paragraph 5.6) and check the wiring.

3) TECHNICAL DATA

| | |
|----------------------------------|-------------------------------------------------------------------------------|
| Power supply: |230Va.c. ±10% 50Hz* |
| Mains/low voltage insulation: | > 2MΩhm 500Vdc |
| Working temperature: | -10 to +55°C |
| Dielectric strength: | mains/low voltage 3750Vac per 1 minute |
| Motor output current: | 3.5A+3.5A max |
| Motor relay commutation current: | 10A |
| Maximum motor power: | 40W (24Vd.c.) |
| Supply to accessories: | 24Va.c. (180mA max absorption) 24Va.c. V safe (180mA max absorption) |
| Gate-open warning light: | N.O. contact (24Va.c./1A max) |
| Blinker: | 24Va.c. 25W max |
| Dimensions: | see figure 1 |
| Fuses: | see figure 2 |

(* other voltages available on request)

BATTERY KIT BT BAT (Fig.6)

| | |
|------------------------------------------------|----------------------|
| Charging voltage: |27.2Vdc |
| Charging current: | 130mA |
| Outside temperature when values were measured: | 25°C |
| Battery capacity: | 2x (12V 1.2Ah) |
| Flat battery protection threshold: | 20.4Vd.c. |
| Battery charging time: | 12/14 hrs |

NOTE: In case of operation with battery back up, the outputs to terminals 11-12 (24 Va.c.) and 13-14 (Vsafe 24 Va.c.) have a voltage of 24 Vd.c., polarised as shown in Fig. 6.

When installing the BT-BAT kit, check for correct connection of the safety devices.

4) TERMINAL BOARD CONNECTIONS (Fig.3)

WARNING – During the wiring and installation operations, refer to the current standards as well as principles of good technical practice.

Wires powered at different voltages must be physically separated, or suitably insulated with at least 1 mm extra insulation. The wires must be clamped by an extra fastener near the terminals, for example by bands. All the connection cables must be kept at an adequate distance from the dissipator.

WARNING! For connection to the mains, use a multipolar cable with a minimum of 3x1.5mm² cross section and complying with the previously mentioned regulations. For example, if the cable is outside (in the open), it has to be at least equal to H07RN-F, but if it is on the inside (or outside but placed in a plastic cable channel) it has to be or at least equal to H05VV-F with section 3x1.5mm².

JP1

1-2 Single-phase mains power supply 230Va.c. ±10% (1=L) (2=N)

JP9

| | |
|-------|---------------------------------------------------------------------------------------------------|
| 3-4-5 | Connection to motor 2: 3 motor + (red) 4 motor - (black), 5 limit-switch control (white) |
| 6-7-8 | Connection to motor 1: 6 motor + (red) 7 motor - (black) 8 limit-switch control (white) |
| 9-10 | Connection to blinker (24Va.c. 20W max) |

JP8

- 11-12 Output 24Va.c. 180mA max - supply to photocells or other devices
- 13-14 Output 24Va.c. V safe 180mA max - supply to photocell transmitters with checking function (Fig.3a).
- 15-16 START pushbutton (N.O.).
- 15-17 STOP pushbutton (N.C.). If not used, leave the bridge 15-17 connected.
- 15-18 Photocell input (N.C.). If not used, leave the bridge 15-18 connected.
- 15-19 Fault input (N.O.). Input for photocells provided with checking N.O. contact (Fig. 3a).
- 15-20 Pedestrian pushbutton input (N.O.). Activation is carried out by motor 2; if the opening cycle has started (not from pedestrian function), the pedestrian command has no effect.

JP7

- 21-22 Output for gate-open warning light output (N.O. contact (24Va.c./1A max)) or alternatively 2nd radio channel (see paragraph 6 on "Configuration")
- 23-24 Antenna input for radio-receiver plug-in board (23 signal–24 braid).

5) PROGRAMMING

The control panel provided with a microprocessor is supplied with function parameters preset by the manufacturer, suitable for standard installations. The predefined parameters can be altered by means of either the incorporated display programmer or UNIPRO.

In the case where programming is carried out by means of UNIPRO, carefully read the instructions relating to UNIPRO, and proceed in the following way.

Connect the UNIPRO programmer to the control unit through the UNIFLAT and UNIDA accessories (See fig. 4). The **LIBRA-MA-R** control unit does not supply the UNIPRO programmer with power, and therefore requires an appropriate supply unit.

Enter the "CONTROL UNITS" menu, and the "PARAMETERS" submenu, then scroll the display screenfuls using the up/down arrows to set the numerical values of the parameters listed below.

For the function logics, refer to the "LOGIC" submenu.

In the case where programming is carried out by means of the incorporated programmer, refer to Fig. A and B and to the paragraph on "Configuration".

6) CONFIGURATION

The display programmer is used to set all the **LIBRA-MA-R** control panel functions.

The programmer is provided with three pushbuttons for menu scrolling and function parameter configuration:

- + menu scrolling/value increment key
- menu scrolling/value reduction key
- OK Enter (confirm) key

The simultaneous pressure of the + and - keys is used to exit the active menu and move to the preceding menu.

The modifications made are only set if the OK key is subsequently pressed. When the OK key is pressed for the first time, the programming mode is entered.

The following pieces of information appear on the display at first:

- Control unit software version
- Number of total manoeuvres carried out (the value is expressed in thousands, therefore the display constantly shows 0000 during the first thousand manoeuvres)
- Number of manoeuvres carried out since the latest maintenance operation (the value is expressed in thousands, therefore the display constantly shows 0000 during the first thousand manoeuvres)
- Number of memorised radio control devices.

When the OK key is pressed during the initial presentation phase, the first menu can be accessed directly.

Here follows a list of the main menus and the respective submenus available. The predefined parameter is shown between square brackets [0].

The writing appearing on the display is indicated between round brackets. Refer to Figures A and B for the configuration procedure.

6.1) PARAMETER MENU (PAR-REF)

- **Automatic Closing Time (tCR) [10s]**
Set the numerical value of the automatic closing time from 3 to 60 seconds.
- **Motor 1 torque (T1 tOR %UE) [50%]**
(UNIPRO ⇒ Advanced parameters ⇒ address 3)
Set the numerical value of the motor 1 torque between 1% and 99%.
- **Motor 2 torque (T2 tOR %UE) [50%]**
(UNIPRO ⇒ Advanced parameters ⇒ address 4)

Set the numerical value of the motor 2 torque between 1% and 99%.

- **Motor 1 slow-down torque (T1 tSLOL) [45%]**
(UNIPRO _ Advanced parameters _ address 8)
Set the numerical value for slow-down torque of motor 1 between 1% and 99%.
- **Motor 2 slow-down torque (T2 tSLOL) [45%]**
(UNIPRO _ Advanced parameters _ address 9)
Set the numerical value for slow-down torque of motor 2 between 1% and 99%.

NOTE: In case of obstacle detection, the Ampere-stop function halts the leaf movement, reverses its motion for 1 sec. and then halts in the STOP status.

 **WARNING: Check that the impact force value measured at the points established by the EN 12445 standard is lower than that specified in the EN 12453 standard.**

 **Incorrect sensitivity setting can cause injuries to persons or animals, or damage to things.**

- **Opening delay time (oPEn dELAY tIFE) [1s]**
Set the opening delay time for motor 1 relative to motor 2, between 1 and 10 seconds.
- **Closing delay time (cL5 dELAY tIFE) [1s]**
Set the closing delay time for motor 2 relative to motor 1, between 1 and 10 seconds.
- **Motor 1 Normal Speed Time (T1 FRSt tIFE) [5s]**
(UNIPRO fi Advanced parameters fi address 6)
Set the time to normal speed (not slowed down), ranging from 1 to 30 seconds.
- **Motor 2 Normal Speed Time (T2 FRSt tIFE) [5s]**
(UNIPRO fi Advanced parameters fi address 7)
Set the time to normal speed (not slowed down), ranging from 1 to 30 seconds.

Note: The slow-down time, on closing and on opening, is obtained by timing one manoeuvre and setting a minimum value for this parameter. If, for example, one manoeuvre lasts 25 seconds, a setting of "normal speed time" to 20s will produce a slow-down time of 5s both on closing and on opening.

- **Slow-down speed (SLow SPEEd) [2]**
(UNIPRO ⇒ Advanced parameters ⇒ address 5)
Set the slow-down speed by choosing from the following values:
0 – slow-down disabled
1 – slow-down to 50% of normal speed
2 – slow-down to 33% of normal speed
3 – slow-down to 25% of normal speed
- **Zone (ZONE) [0]**
Set the zone number between a minimum value of 0 and a maximum value of 127. See paragraph 7 on "Serial connection".

6.2) LOGIC MENU (LOG IC)

- **TCA (tCR) [OFF]**
ON Activates automatic closing
OFF Excludes automatic closing
- **3 Steps (3 STEP) [OFF]**
ON Enables 3-step logic. A Start impulse has the following effects:
door closed: opens
on opening: stops and enters TCA (if configured)
door open: closes
on closing: stops and reopens
OFF Enables 4-step logic. A Start impulse has the following effects:
door closed: opens
on opening: stops and enters TCA (if configured)
door open: closes
on closing: stops and does not enter TCA (stop)
after stopping: opens
- **Impulse lock (IBL oPEn) [OFF]**
ON The Start impulse has no effect during the opening phase.
OFF The Start impulse becomes effective during the opening or closing phase.
- **Rapid closing (FRSt cL5) [OFF]**
ON Closes the gate after photocell disengagement, before waiting for the end of the TCA set.
OFF Command not entered.
- **Photocells on opening (PHOt c. oPEn) [OFF]**
(UNIPRO ⇒ Advanced logics ⇒ address 14)
ON: In case of obscuring, this excludes photocell operation on opening. During the closing phase, it immediately reverses the motion.
OFF: In case of obscuring, the photocells are active both on opening and on closing. When a photocell is obscured on closing, it reverses the motion only after the photocell is disengaged.
- **Photocell test (tESt PHOt) [OFF]**

ON Activates photocell check
 OFF Deactivates photocell check
 If this setting is not activated (OFF), it inhibits the photocell checking function, allowing connection of devices not provided with additional checking contact.

- **Gate-open or 2nd radio channel warning light (5cR 2ch) [OFF]**

ON The output between terminals 21 and 22 is configured as Gate-open warning light, in this case the 2nd radio channel controls pedestrian opening.

OFF The output between terminals 21 and 22 is configured as 2nd radio channel.

- **Motors in operation (i Pakt on) [OFF]**

ON Only motor 2 is in operation (terminals 3, 4 and 5).

With this configuration, the pedestrian input is disabled.

OFF Both motors are in operation.

- **Lock hold (bLack PErs iSt) [OFF] (Fig. 5)**

ON To be used when the mechanical closing backstop is fitted.

This function activates leaf pressure on the mechanical backstop, without this being considered as an obstacle by the Ampere-stop sensor. Therefore the rod continues its travel for another 0.5 sec. after detecting the closing limit switch or upon reaching the mechanical backstop. So by activating the closing limit switches slightly earlier, the leaves will come to a perfect halt against the backstop. (Fig. 5a)

OFF To be used when no mechanical closing backstop is fitted.

Movement is exclusively halted by activation of the closing limit switches; in this case proceed to carrying out precise setting of the closing limit-switch activation. (Fig. 5b)

- **Hold-to-run control (hold-to-run) [OFF]**

ON Hold-to-run operation: the manoeuvre continues as long as the control key is kept pressed.

WARNING!: Enabling the Hold-to-run logic entails a different use of the START and PEDESTRIAN buttons:

START takes on the hold-to-run **OPEN** function

PEDESTRIAN takes on the hold-to-run **CLOSE** function

OFF Impulse operation, according to the 3 or 4 step logic.

- **Fixed code (F iHEd codE) [OFF]**

(UNIPRO ⇒ Advanced logics ⇒ address 13)

ON The receiver is configured for operation in fixed-code mode, see paragraph on "Radio Transmitter Cloning".

OFF The receiver is configured for operation in rolling-code mode, see paragraph on "Radio Transmitter Cloning".

- **Radio transmitter programming (rRd ia P-rad) [ON]**

(UNIPRO ⇒ Advanced logics ⇒ address 15)

ON This enables transmitter storage via radio:

1 – First press the hidden key (P1) and then the normal key (T1, T2, T3 or T4) of a transmitter already memorised in standard mode by means of the radio menu.

2 – Within 10s press the hidden key (P1) and the normal key (T1, T2, T3 or T4) of a transmitter to be memorised.

The receiver exits the programming mode after 10s, other new transmitters can be entered before the end of this time.

This mode does not require access to the control panel.

OFF This disables transmitter storage via radio.

The transmitters can only be memorised using the appropriate Radio menu.

- **Master/Slave (rRSLEr) [OFF]**

ON The control panel is set as Master in a centralised connection (see Paragraph 7).

OFF The control panel is set as Slave in a centralised connection (see Paragraph 7).

- **Start-Open selection (StArE - oPEr) [OFF]**

ON The input between the two terminals 15-16 acts as open

OFF The input between the two terminals 15-16 acts as start

6.3) RADIO MENU (rRd ia)

- **Add**

Allows you to add one key of a radio control device to the receiver memory; after storage it displays a message showing the receiver number in the memory location (from 01 to 64).

Add Start button (Rdd StArE)

associates the required key to Start command

Add 2ch button (Rdd 2ch)

associates the required key to 2nd radio channel

- **Read (rERd)**

Checks one key of a receiver; if stored it displays a message showing the receiver number in the memory location (from 01 to 64), and the key number (T1, T2, T3 or T4).

- **Eliminate list (ERSE 54)**

WARNING! Completely removes all memorised radio control devices

from the receiver memory.

- **Receiver code reading (RX code)**

This displays the code entered in the receiver (par. 11).

Consult paragraphs 8, 9, 10 and 11 for further information concerning the advanced functions of the Clonix incorporated receiver.

6.4) LANGUAGE MENU (LRnGUAGE)

Allows you to set the language on the display programmer.

- **ITALIAN (ItR)**

- **FRENCH (FrR)**

- **GERMAN (dEU)**

- **ENGLISH (EnG)**

- **SPANISH (ESP)**

6.5) DEFAULT MENU (dFRULt)

Restores the preset default values on the control unit. After restoring, a new autoselection operation must be carried out.

6.6) DIAGNOSTICS AND MONITORING

The display on the **LIBRA-MA-R** panel shows some useful information, both during normal operation and in the case of malfunctions.

Diagnostics:

In the case of malfunctions, the display shows a message indicating which device needs to be checked:

STRT = START input activation

STOP = STOP input activation

PHOT = PHOT input activation

FLT = FAULT input activation for checked photocells

In the case where an obstacle is found, the **LIBRA-MA-R** panel stops the door and activates a reverse manoeuvre; at the same time the display shows the "AMP" message.

Monitoring:

During the opening and closing phases, the display shows four digits separated by a dot, for example 35.40. The digits are constantly updated during the manoeuvre, and represent the maximum torque reached by motor 1 (35) and motor 2 (40).

These values allow the torque setting to be corrected.

If the maximum torque value reached during the manoeuvre gets sensibly close to the value set in the parameter menu, malfunctions may occur in the future following wear or slight door deformation.

It is therefore advisable to check the maximum torque reached during some of the manoeuvres carried out in the course of installation, and if necessary set a value about 15-20 percent points higher in the parameter menu.

6.7) AUTASET MENU (RULt oSEt)

Allows you to automatically set the Motor torque.

WARNING!! The autoselection operation is only to be carried out after checking the exact leaf (opening/closing) movement, and correct limit-switch activation.

As soon as the OK pushbutton is pressed, the ".... .." message is displayed, and the control unit executes an opening manoeuvre followed by a closing manoeuvre, during which the minimum torque value needed for leaf movement is automatically set.

During this phase, it is important to avoid obscuring the photocells, as well as using the START, STOP or PED commands and the display.

After this, if autoselection has been successfully completed, the control unit displays the "OK" message and, after pressing any key, returns to the Autoselection menu.

If, on the other hand, the control unit displays the "KO" message, it means that the autoselection procedure has not been successfully completed; it is thus necessary to check the wear condition of the gate and the regular movement of the leaves before proceeding to a new autoselection operation.

WARNING! During the autoselection phase, the obstacle detection function is not active, therefore the installer must control the automation movement and prevent persons and things from approaching or standing within the automation working range.

In the case where buffer batteries are used, autoselection must be carried out with the control panel supplied by mains power voltage.

 **WARNING: Check that the impact force value measured at the points established by the EN 12445 standard is lower than that specified in the EN 12453 standard.**

 **Incorrect sensitivity setting can cause injuries to persons or animals, or damage to things.**

7) STATISTICS

Having connected the UNIPRO programmer to the control unit, enter the

CONTROL UNIT / STATISTICS menu and scroll the screenful showing the statistical parameters:

- Board microprocessor software version.
- Number of cycles carried out. If motors are replaced, count the number of manoeuvres carried out up to that time.
- Number of cycles carried out from the latest maintenance operation. It is automatically set to zero after each self-diagnosis or parameter writing.
- Date of latest maintenance operation. To be updated manually from the appropriate menu "Update maintenance date".
- Installation description. 16 characters can be entered for installation identification.

8) INTEGRATED RECEIVER TECHNICAL SPECIFICATION

Receiver output channels:

- output channel 1, if activated, controls a START command.
- output channel 2, if activated, controls the excitation of the 2nd radio channel relay for 1s.

Transmitter versions which can be used:

all Rolling Code transmitters compatible with



ANTENNA INSTALLATION

Use an antenna tuned to 433MHz.

For Antenna-Receiver connection, use RG8 coaxial cable.

The presence of metallic masses next to the antenna can interfere with radio reception. In case of insufficient transmitter range, move the antenna to a more suitable position.

9) RECEIVER CONFIGURATION

The on-board receiver combines characteristics of utmost safety in copying variable code (rolling code) coding with the convenience of carrying out transmitter "cloning" operations thanks to an exclusive system.

Cloning a transmitter means creating a transmitter which can be automatically included within the list of the transmitters memorised in the receiver, either as an addition or as a replacement of a particular transmitter.

Cloning by replacement is used to create a new transmitter which takes the place of the one previously memorised in the receiver; in this way a specific transmitter can be removed from the memory and will no longer be usable. Therefore it will be possible to remotely program a large number of additional transmitters or, for example, replacement transmitters for those which have been lost, without making changes directly to the receiver.

When coding safety is not a decisive factor, the on-board receiver allows you to carry out fixed-code additional cloning which, although abandoning the variable code, provides a high number of coding combinations, therefore keeping it possible to "copy" any transmitter which has already been programmed.

PROGRAMMING

Transmitter storage can be carried out in manual mode or by means of the UNIRADIO programmer which allows the complete installation database to be managed through the Eedbase software.

In this second case, receiver programming takes place through the connection of UNIRADIO to the LIBRA-MA-R control panel, using the UNIFLAT and UNIDA accessories as indicated in Fig. 4.

10) MANUAL PROGRAMMING

In the case of standard installations where advanced functions are not required, you can proceed to manual storage of the transmitters, making reference to fig. B for basic programming.

- If you wish the transmitter to activate output 1 (START) by means of key1, key2, key3 or key4, enter the transmitter in menu "Start key", as in fig. B.
- If you wish the transmitter to activate output 2 (2nd radio channel relay) by means of key1, key2, key3 or key4, enter the transmitter in menu "2nd ch. key", as in fig. B.

Note: Hidden key P1 appears differently depending on the transmitter model.

For transmitters with hidden key, press hidden key P1 (fig. B1). For transmitters without hidden key, the key P1 function corresponds to simultaneously pressing the 4 transmitter keys or, after opening the battery compartment, bridging the two P1 points by means of a screwdriver (fig. B2).

IMPORTANT NOTE: ATTACH THE ADHESIVE KEY LABEL TO THE FIRST MEMORISED TRANSMITTER (MASTER).

In the case of manual programming, the first transmitter assigns the key code to the receiver; this code is necessary in order to carry out subsequent cloning of the radio transmitters.

11) RADIO-TRANSMITTER CLONING

Rolling-code cloning / Fixed-code cloning

Make reference to the UNIRADIO Instructions and the CLONIX Programming Guide.

11.1) ADVANCED PROGRAMMING: COLLECTIVE RECEIVERS

Make reference to the UNIRADIO Instructions and the CLONIX Programming Guide.

12) SERIAL CONNECTION USING SCS BOARD (Fig.6)

The LIBRA-MA-R control panel allows several automation units (SCS) to be connected in a centralised way by means of appropriate serial inputs and outputs. This makes it possible to use one single command to open and close all the automation units connected.

Following the diagram in Fig.6, proceed to connecting all the LIBRA-MA-R control panels, exclusively using a telephone-type line.

Should a telephone cable with more than one pair be needed, it is indispensable to use wires from the same pair.

The length of the telephone cable between one appliance and the next must not exceed 250 m.

At this point, each of the LIBRA-MA-R control panels must be appropriately configured, by setting a MASTER unit first of all, which will have control over all the others, to be necessarily set as SLAVE (see logic menu).

Also set the Zone number (see parameter menu) between 0 and 127.

The zone number allows you to create groups of automation units, each one answering to the Zone Master unit. Each zone can only be assigned one Master unit, the Master unit in zone 0 also controls the Slave units in the other zones.

13) SCRAPPING

Warning: This operation should only be carried out by qualified personnel. Materials must be disposed of in conformity with the current regulations. In case of scrapping, the automation devices do not entail any particular risks or danger. In case of materials to be recycled, these should be sorted out by type (electrical components, copper, aluminium, plastic etc.).

14) DISMANTLING

Warning: This operation should only be carried out by qualified personnel. When the control unit is disassembled to be reassembled on another site, proceed as follows:

- Disconnect the power supply and the entire electrical installation.
- In the case where some of the components cannot be removed or are damaged, they must be replaced.

The descriptions and illustrations contained in the present manual are not binding. The Company reserves the right to make any alterations deemed appropriate for the technical, manufacturing and commercial improvement of the product, while leaving the essential product features unchanged, at any time and without undertaking to update the present publication.

Fig. A

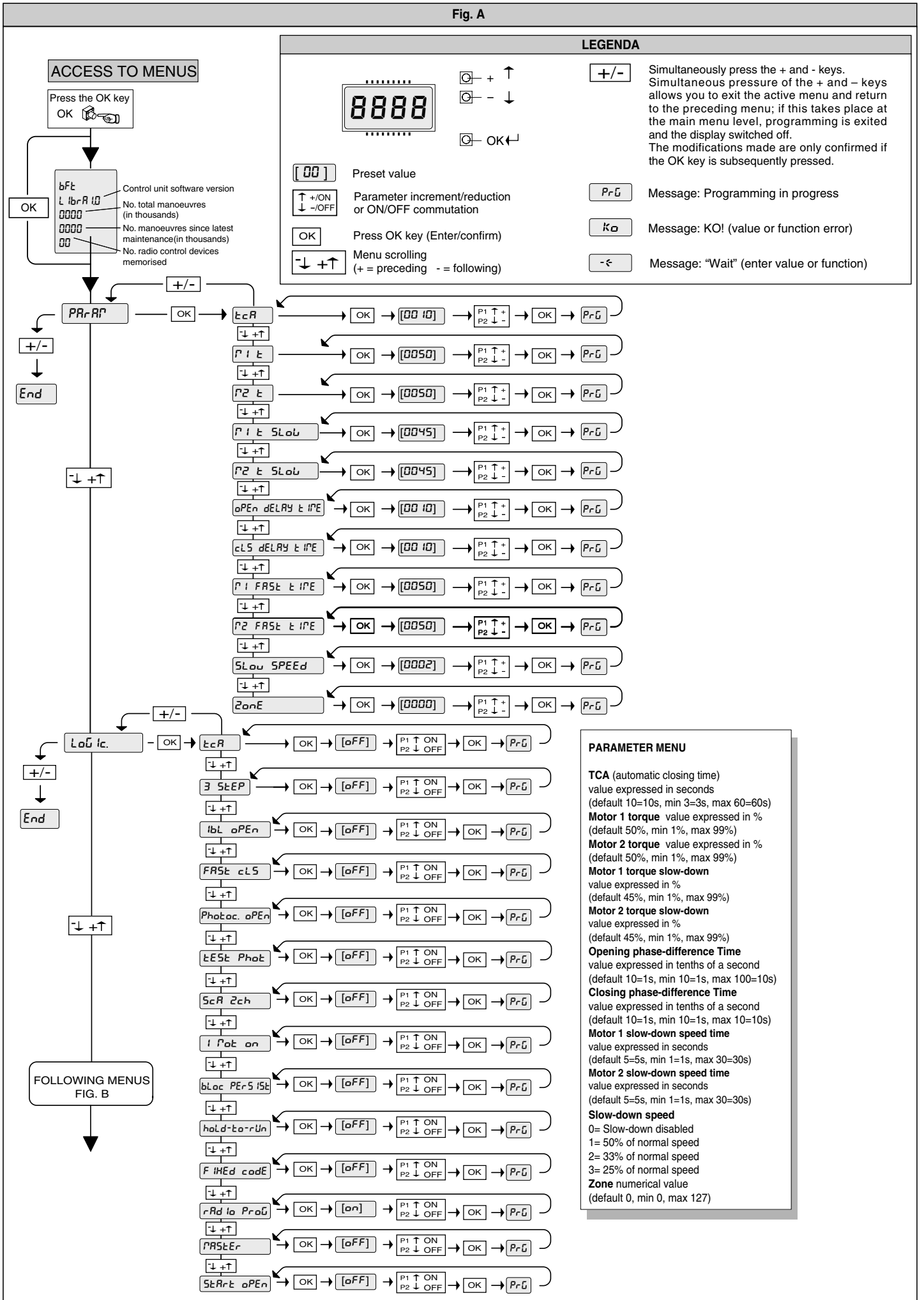

LEGENDA

- + ↑
- ↓
- OK ↵
- Simultaneously press the + and - keys. Simultaneous pressure of the + and - keys allows you to exit the active menu and return to the preceding menu; if this takes place at the main menu level, programming is exited and the display switched off. The modifications made are only confirmed if the OK key is subsequently pressed.
- Message: Programming in progress
- Message: KO! (value or function error)
- Message: "Wait" (enter value or function)
- Preset value
- Parameter increment/reduction or ON/OFF commutation
- Press OK key (Enter/confirm)
- Menu scrolling (+ = preceding - = following)

PARAMETER MENU

- TCA** (automatic closing time)
value expressed in seconds
(default 10=10s, min 3=3s, max 60=60s)
- Motor 1 torque** value expressed in %
(default 50%, min 1%, max 99%)
- Motor 2 torque** value expressed in %
(default 50%, min 1%, max 99%)
- Motor 1 torque slow-down**
value expressed in %
(default 45%, min 1%, max 99%)
- Motor 2 torque slow-down**
value expressed in %
(default 45%, min 1%, max 99%)
- Opening phase-difference Time**
value expressed in tenths of a second
(default 10=1s, min 10=1s, max 100=10s)
- Closing phase-difference Time**
value expressed in tenths of a second
(default 10=1s, min 10=1s, max 10=10s)
- Motor 1 slow-down speed time**
value expressed in seconds
(default 5=5s, min 1=1s, max 30=30s)
- Motor 2 slow-down speed time**
value expressed in seconds
(default 5=5s, min 1=1s, max 30=30s)
- Slow-down speed**
0= Slow-down disabled
1= 50% of normal speed
2= 33% of normal speed
3= 25% of normal speed
- Zone** numerical value
(default 0, min 0, max 127)

Fig. B

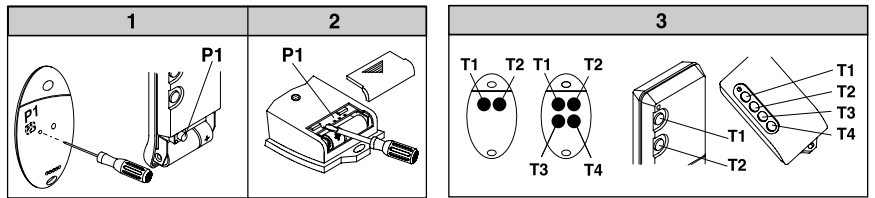

PRECEDING MENUS
FIG. A

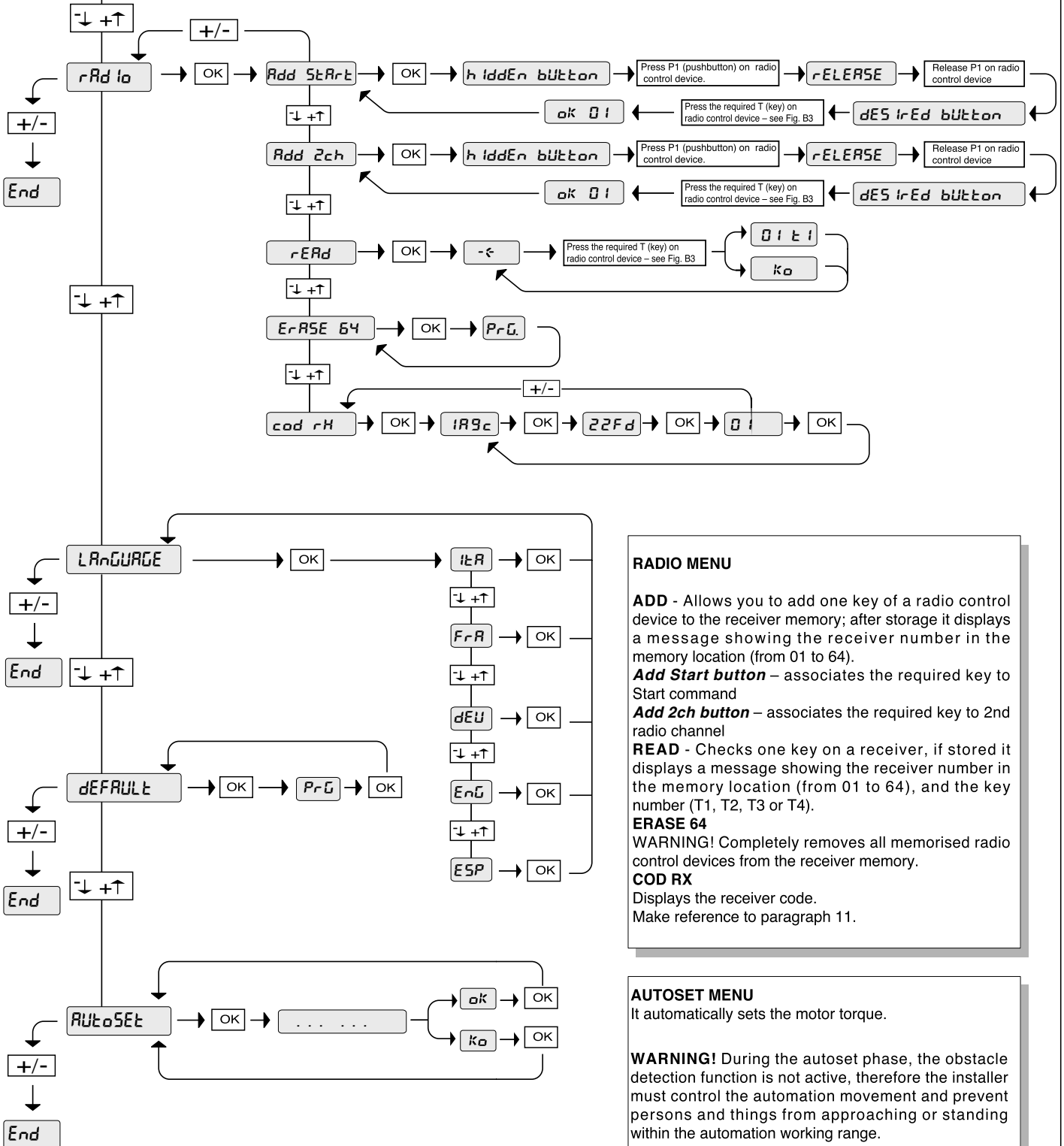

RADIO MENU

ADD - Allows you to add one key of a radio control device to the receiver memory; after storage it displays a message showing the receiver number in the memory location (from 01 to 64).

Add Start button – associates the required key to Start command

Add 2ch button – associates the required key to 2nd radio channel

READ - Checks one key on a receiver, if stored it displays a message showing the receiver number in the memory location (from 01 to 64), and the key number (T1, T2, T3 or T4).

ERASE 64
WARNING! Completely removes all memorised radio control devices from the receiver memory.

COD RX
Displays the receiver code.
Make reference to paragraph 11.

AUTOSET MENU

It automatically sets the motor torque.

WARNING! During the autoset phase, the obstacle detection function is not active, therefore the installer must control the automation movement and prevent persons and things from approaching or standing within the automation working range.

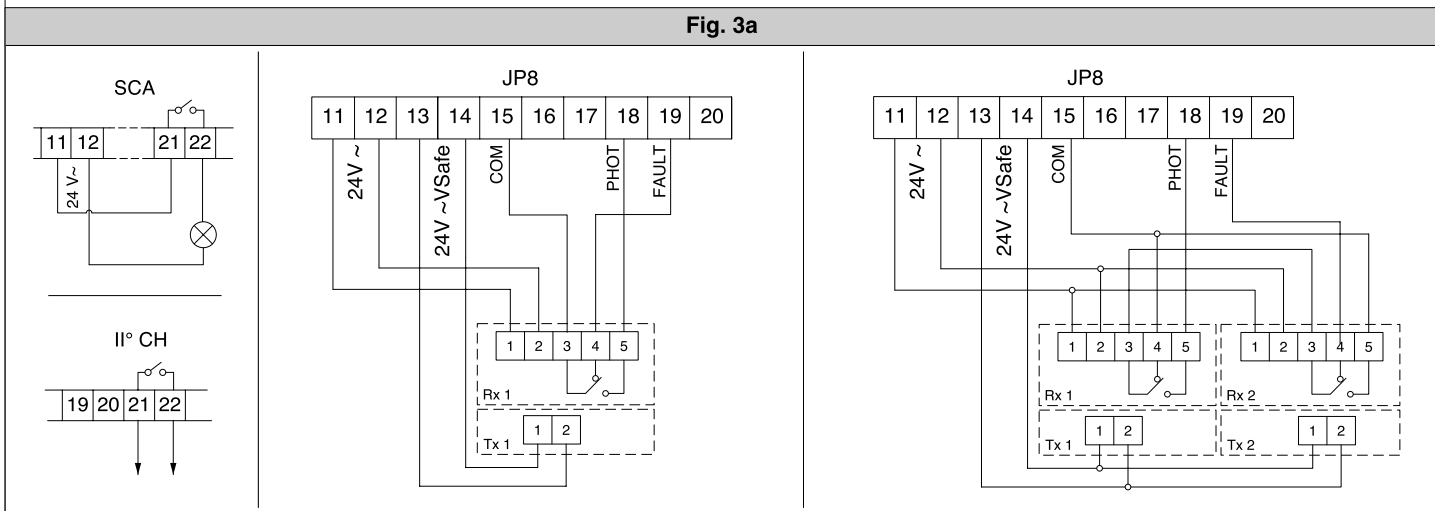
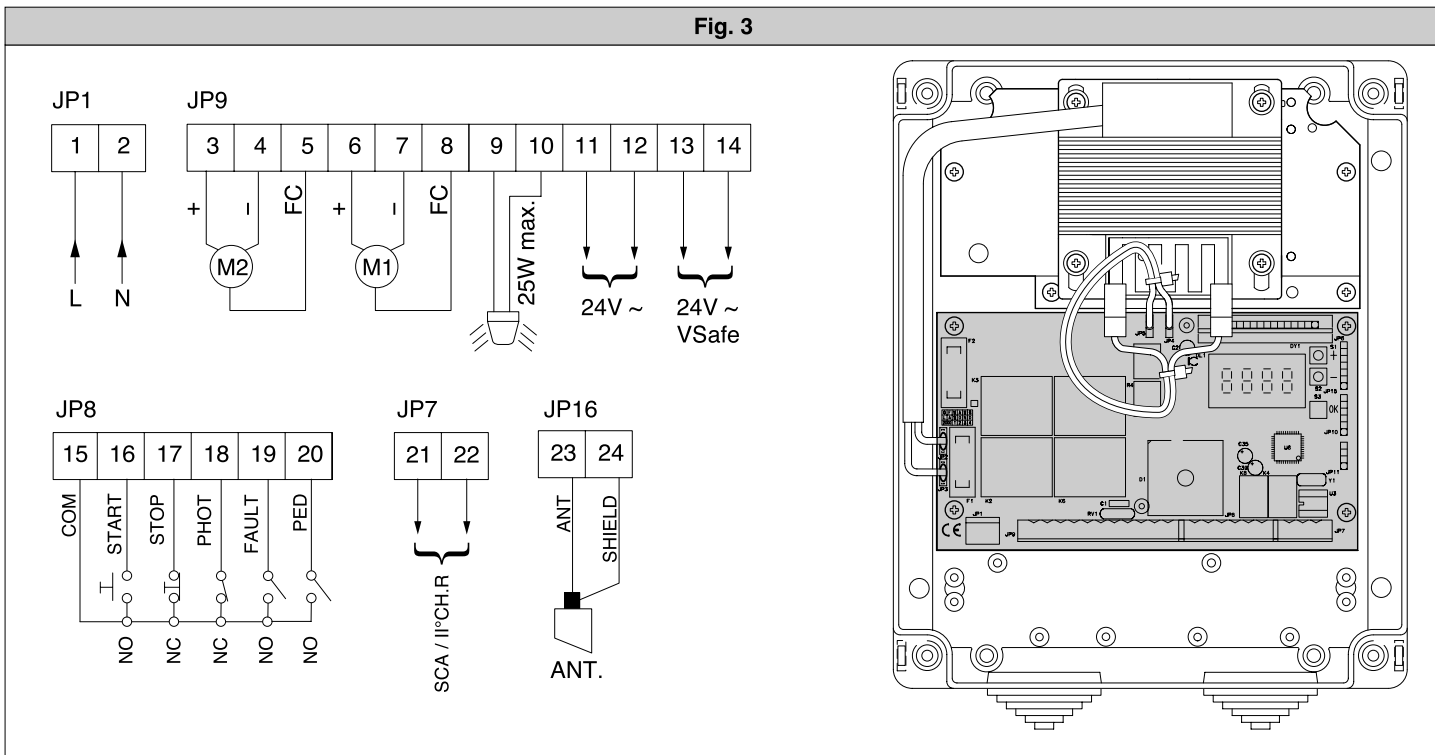
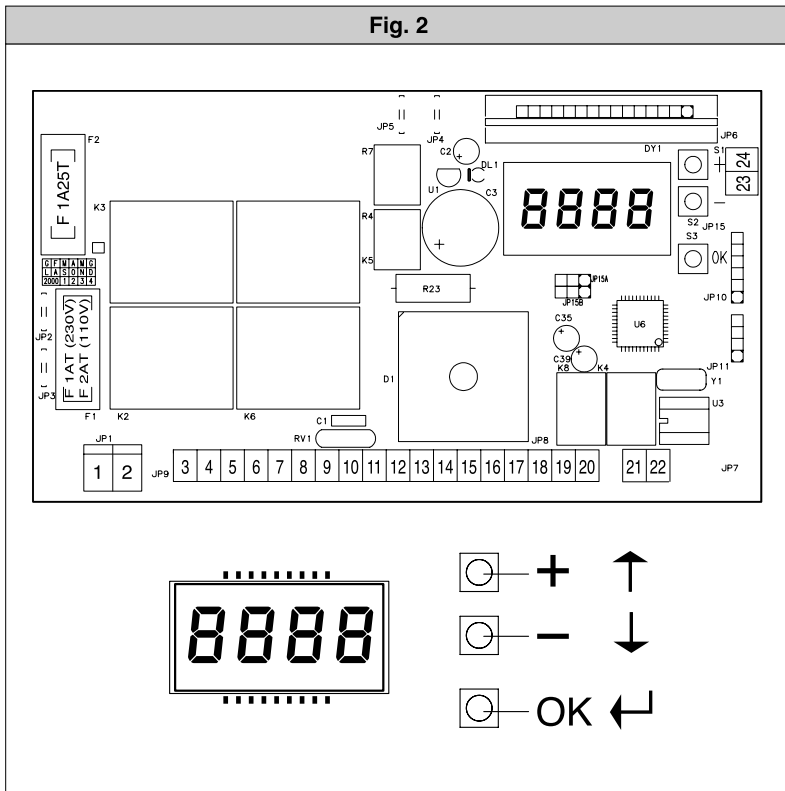
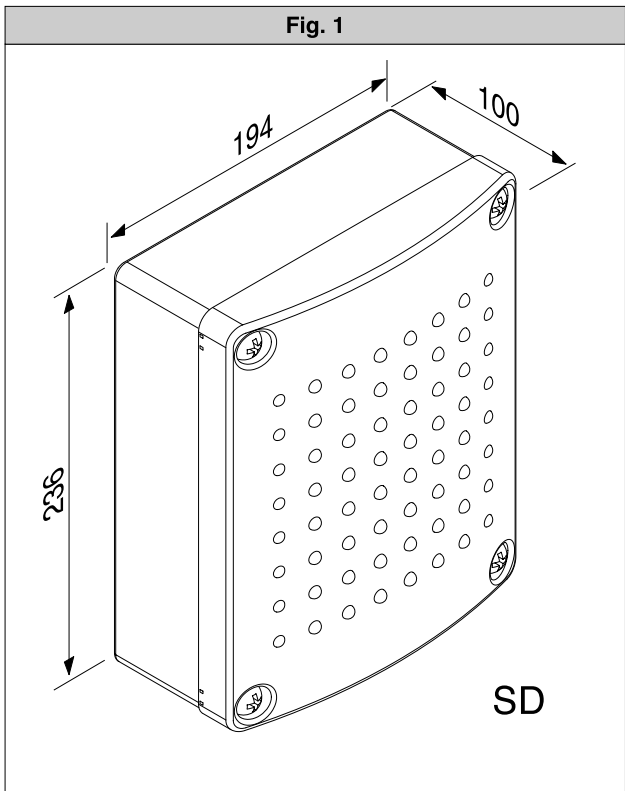

Fig. 18

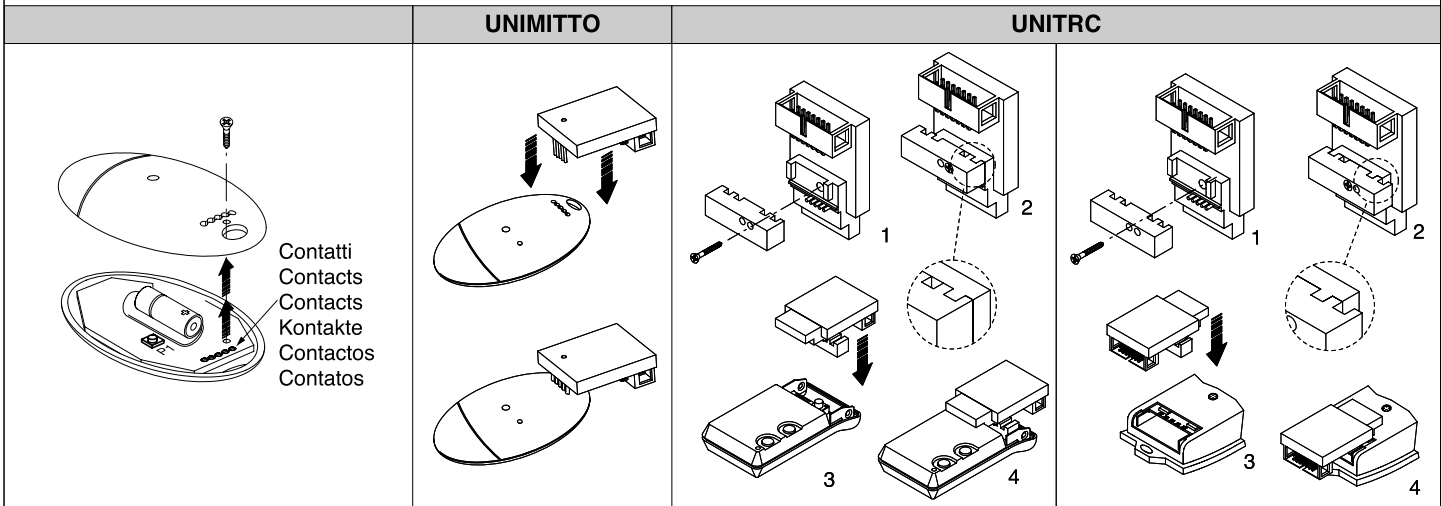
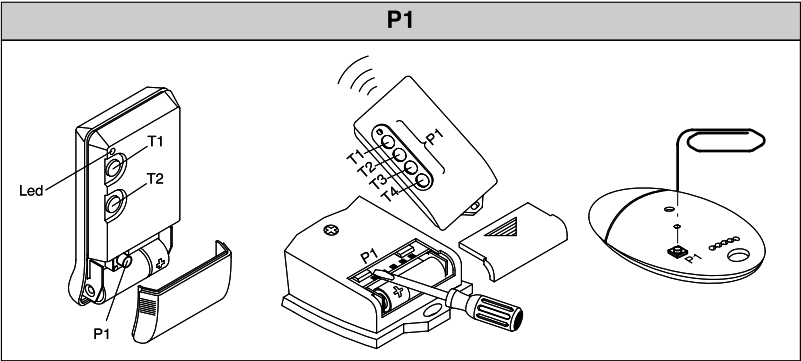
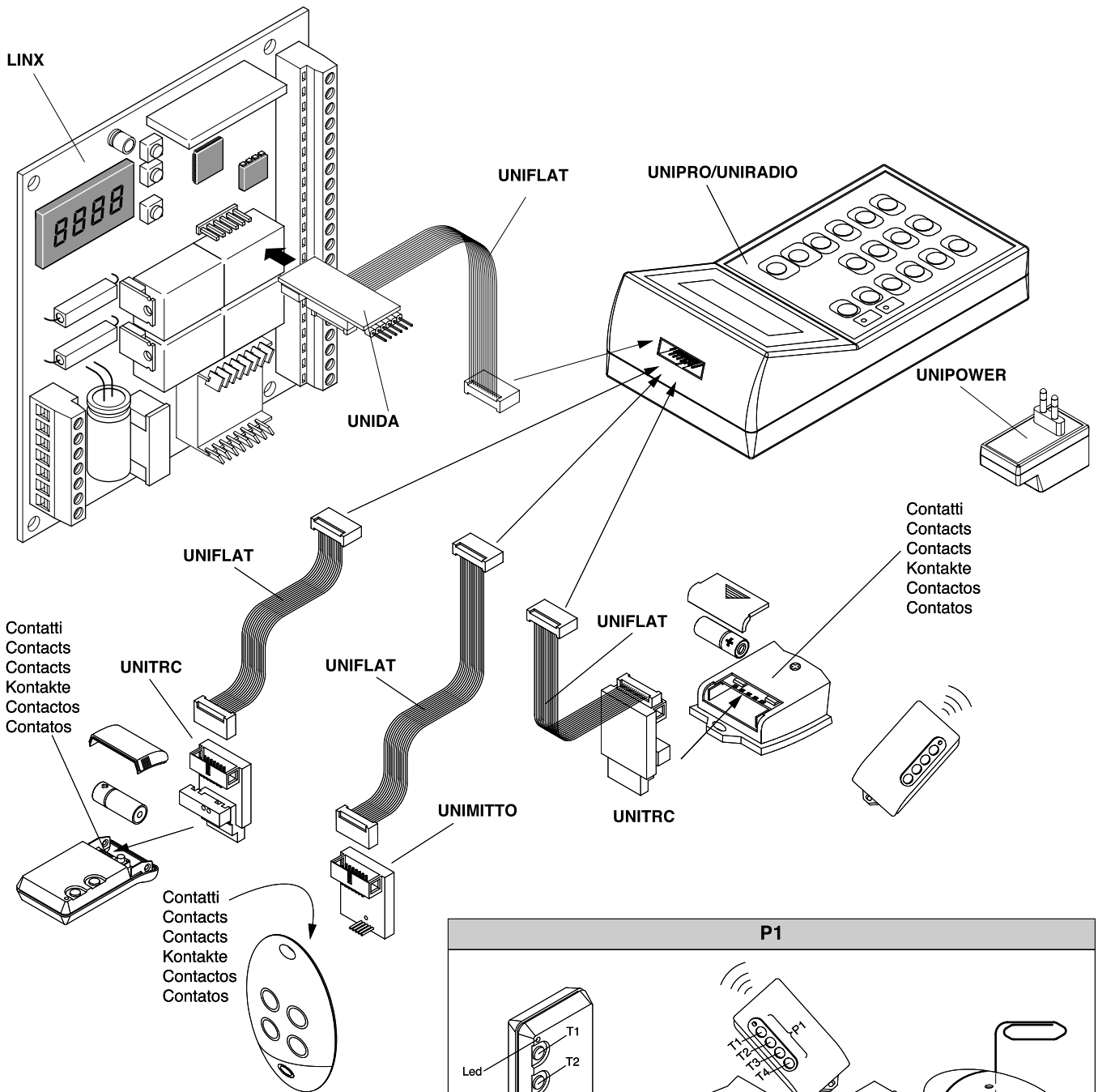

Fig. 5

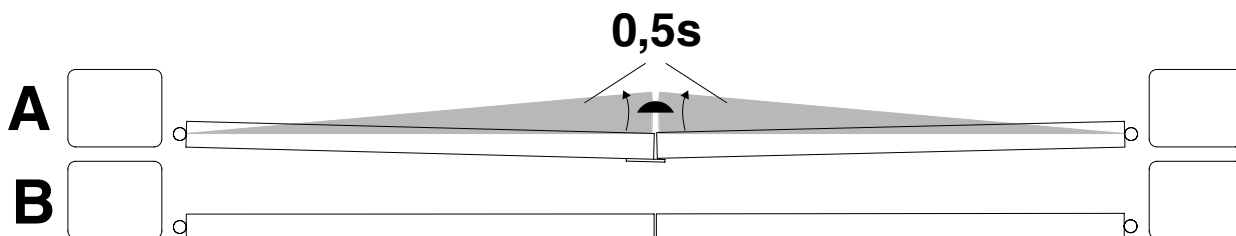
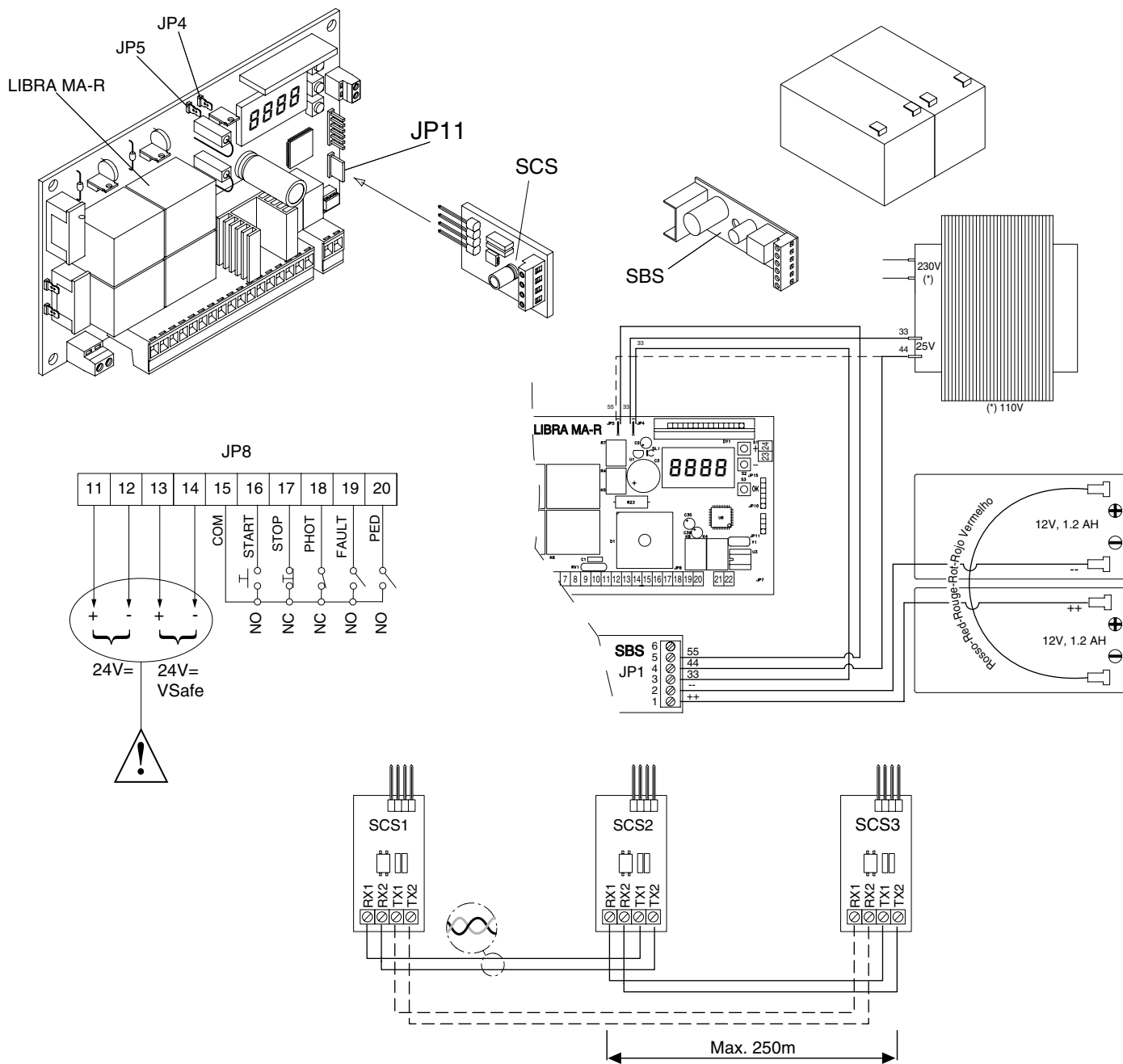

Fig. 6



BFT FRANCE

AUTOMatismes BFT FRANCE
 13 Bld E. Michelet, 69008 Lyon
 e-mail: infofrance@bft.it

Tel. (0033) 04 78 76 09 88
 Fax (0033) 04 78 76 92 23

BFT DEUTSCHLAND

BFT Torantriebssysteme GmbH
 Johannisstr. 14, D-90763 Fürth
 http://www.bft-torantriebe.de

Tel. 0049 911 773323
 Fax 0049 911 773324

BFT S.p.a.

ITALIA

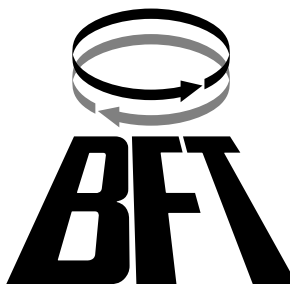

Via Lago di Vico, 44
 36015 Schio (VI)
 Tel.naz. 0445 696511
 Tel.int. +39 0445 696533
 Fax 0445 696522
 Internet: www.bft.it
 E-mail: sales@bft.it