

## Assembly Instructions

*Safety-contact-edges may only be assembled and installed by authorized personnel!*

*Pre-assembled ASO delivered end cap with contact plug includes:*

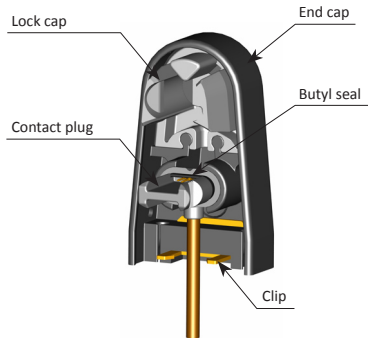

**Contact plug with cable**



**Contact plug with resistor**

### 1. Cutting the safety-contact-edge

The safety-contact-edge is cut 20 mm shorter than the final length dimension to allow for the length of the end caps on each end. Make sure that the safety-contact-edge is cut clean and straight.

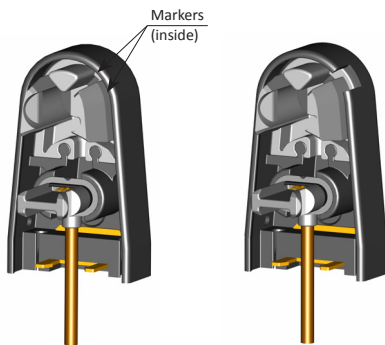
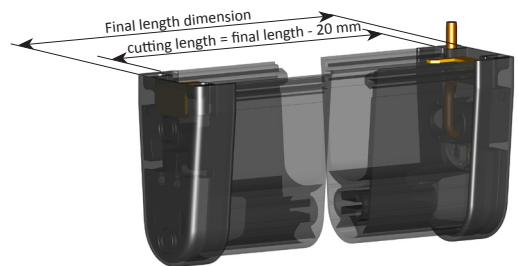

### 2. Preparing end caps

#### a) Notch for the weather-sealing lip

When assembling safety-contact-edges with weather-sealing lips, the end caps have to be notched where indicated to allow for the weather-sealing lip(s).

#### b) Connection cable

The connection cable exits the bottom of the end cap.

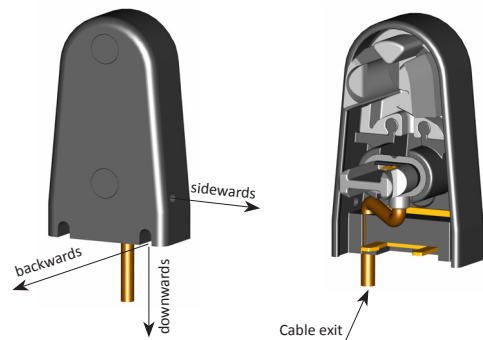
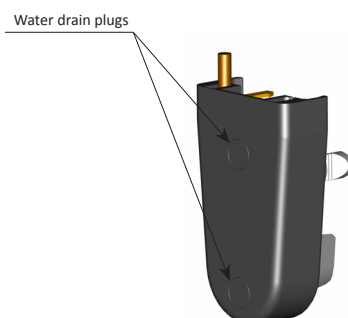

#### c) Water drain plugs

For installations in contact with water, it is necessary to remove water drain plugs. If the edge is to be mounted horizontally, remove drain plugs from both ends. If the edge is mounted vertically, just remove the lower drain plug.

**Please note:**

The ambient temperature during assembly of the contact plug to the edge profile should be between 10° and 30° C at a relative humidity between 40% and 70%.

**3. Insert the contact plug**

- Insert the plug, which is fixed to the end cap, into the electrical switching chamber of the safety-contact-edge.
- The elastic butyl seal has to be pressed on tight to the edge (Max. 6,5 mm from plug base to profile)

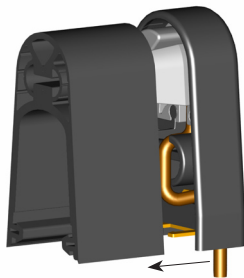
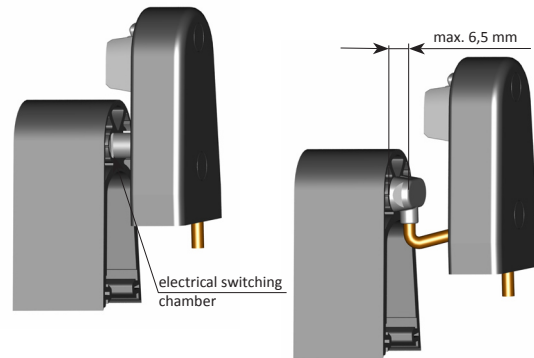

**4. Put on end caps**

Release the contact plug from end cap and then snap in the contact lock cap on the contact plug until it clicks into place. Apply pressure to ensure the end cap plug is fully inserted into the contact edge.

**5. Electrical testing of the contact edge**

Measure the contact edge with a multimeter. In rest position, the resistance value has to be 8,2 kΩ ± 500 Ω. When edge is activated, the resistance should not exceed 500 Ω.

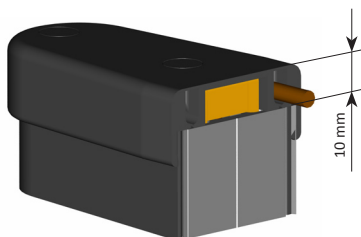
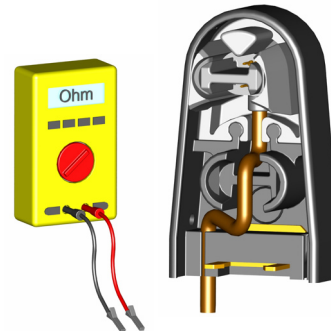

**6. Cutting mounting rail**

The mounting rail has to be 20 mm shorter than the final dimension of the contact edge.

**ASO GmbH excludes all liability for damage caused as a result of an incorrect assembly and installation of the contact edges.**

Technical changes reserved

as of October 18th 2012

15.DB.10.003 Technical data Rev 03

Am Garock 8 • D-33154 Salzkotten  
www.asosafety.com • e-mail: info@asosafety.com