

Gate Controller ATC 100

Installation and Operating Manual



ASO **Safety**
Solutions

Antriebs- und Steuerungstechnik
Am Garock 8 • D-33154 Salzkotten
Tel.: 0 52 58/93 27-0 • Fax: 0 52 58/34 48
www.asogmbh.de • e-mail: info@asogmbh.de

Contents

1. Important safety warnings	3
2. General	4
2.1 Highest safety for humans and objects	4
2.1 The advantages of the ATC 100	4
3. System components	5
3.1 LED - indicators	6
4. Electrical connection	7
4.1 Mains voltage	8
4.1.1 Connection three-phase motor	8
4.1.2 Connection single-phase motor	9
4.2 Relay outputs (potential free)	10
4.3 STOP inputs	11
4.4 Inputs for control switches	11
4.5 Light-barrier inputs	11
4.6 Safety-contact-edge connection	12
4.7 Limit switches inputs	12
4.8 Power supply 24V	12
5. Plug-on modules	13
5.1 Control modules	13
5.2 Auxiliary modules	13
5.2.1 Inductive safety controller ISK 70-75	13
5.2.2 Time switch ZU3	13
5.2.3 Radio controller	13
6. Program settings	14
6.1 Automatic	14
6.2 Manual mode	14
6.3 Input	14
6.4 Diagnosis	16
7. Jumper settings	17
8. Article numbers	17
9. Enclosure	17
9.1 Mounting of the enclosure	17
9.2 Enclosure dimensions	17
10. Technical data	18

1. Important safety notes

- This manual must be available at the installation place of the gate controller at all time.
Any person assigned with the installation, operation and maintenance of the gate controller must read and follow this manual.
- Basic condition for safety-related handling and the failure-free operation of the gate controller is the knowledge of the fundamental safety guidelines and the safety regulations of the European standards and the professional associations.
- This manual, in particular the safety guidelines, are to be considered from all persons who works on the gate controller
- For safety reasons the electrical installation is only to accomplished from a qualified electrical personnel according to the locally valid regulations for the prevention of accidents.
- The opening of the gate-controller is only permitted with switched off power supply. For the disconnection of the power supply a main power switch or the use of a CEE plug is to be planned. The main power switch or the power supply plug must be easily accessible.
- Before performing any work on the gate controller, the voltage must be disconnected and verified that there is no live voltage.
- If the potential free contacts of the relay outputs are connected to a dangerous voltage, it is also necessary to switch off these voltages before working on the gate controller.
- The operation of the control with an opened enclosure is not permitted.
- Switching on and/or operation of a dewed gate controller is not permitted and can destroy the controller.
- The used stage nipple cable insertion may only cut to the stage, so that the insertion of the cable corresponds to the IP 54 protection against water and foreign objects.
Damaged stage nipples must be exchanged immediately against intact.
- The intended use of the safety controller is the use at gates and doors. A different, or beyond this, use is not intended. The manufacturers do not assume liability for damages and malfunctions caused by not intended use.
The manufacturer must permit the use in special applications.
- Faults, which can affects the safety, must be eliminated immediately.
- With the use of the gate in the manual mode operation it is to be guaranteed that the gate range can be seen by the operator.
- At the start-up operation and at the annually prescribed maintenance the parameter settings and the correct function of the safety device must be examined.
The settings of the parameters and the maintenance of the gate situation may only checked by a qualified personnel. The results must be documented in such a way that it can be viewed and understood at any time.
- Never allow that children operate the gate controller. Take care that children don't play in the near or with the gate. Keep radio remote controllers in a place which is inaccessible to children.
- The manufacturer and the user of the gate, at which the controller is used, are responsible for the compliance with all valid safety regulations.
- The gate controller guarantees for itself a functional safety, however not the complete safety of the gate. Therefore, a safety consideration for the complete gate, according to the machinery directive 98/37 EC or to the appropriate product standard, is necessary before using this gate controller.
- The gate controller contains no user-serviceable parts. Any unauthorised modifications and/or repairs of the gate controller will terminate any guarantee and claim against the manufacturer.



The ATC 100 gate controller must be regarded as a component.

It lies in the responsibility of the gate manufacturer and/or gate operator to ensure that its gate meets all relevant regulations and standards (machinery directive, EMC guideline etc.).

Technical and operating relevant changes to the products and devices specified in this documentation are reserved at any time also without advance notice.

Gate Controller ATC 100

2. General

The free parametrizable gate controller ATC 100 is developed for controlling 400V three-phase current and 230V one-phase current motors on sliding gates, roller doors, roller grills, and sectional doors in industrial, commercial and private use. As a result of the large flexibility, the variety of connection possibilities and the combination with further optional plug-on modules the gate controller ATC 100 can be used in many areas.

By the menu-driven programming of the ATC 100 it is succeeded to simply arrange a complex control that fulfils many requirements and functions.

2.1 Highest safety for humans and object

- Complete testing of all safety-related parts before each gate movement
- Testing the contactor contacts on correct function before each movement
- In case of an error a second shut-down circuit for the motor current is available by the additional release contactor.

As a compact unit the ATC 100 fulfils the requirements of the latest gate standards.

2.2 The advantages of the ATC 100

- compact enclosure
- connecting possibility for three-phase and one-phase motors through the integrated reversing contactors
- simple, menu-driven programming of the controller by four buttons
- if necessary the pluggable control module offers protection against unauthorized access of the adjusted parameters
- malfunction and operating conditions are indicated by the two-line LCD display and by Led's
- integrated two-channel evaluation for stationary safety contact edges
- socket for inductive safety system ISK to monitoring the travelling safety contact edges at the gate wing
- socket for timer
- socket for radio controller
- alternatively complete or partial automatic revision after operating the safety contact edges
- pluggable connecting terminals for simpler assembly
- ALL-IN-ONE solution for the gate-automation

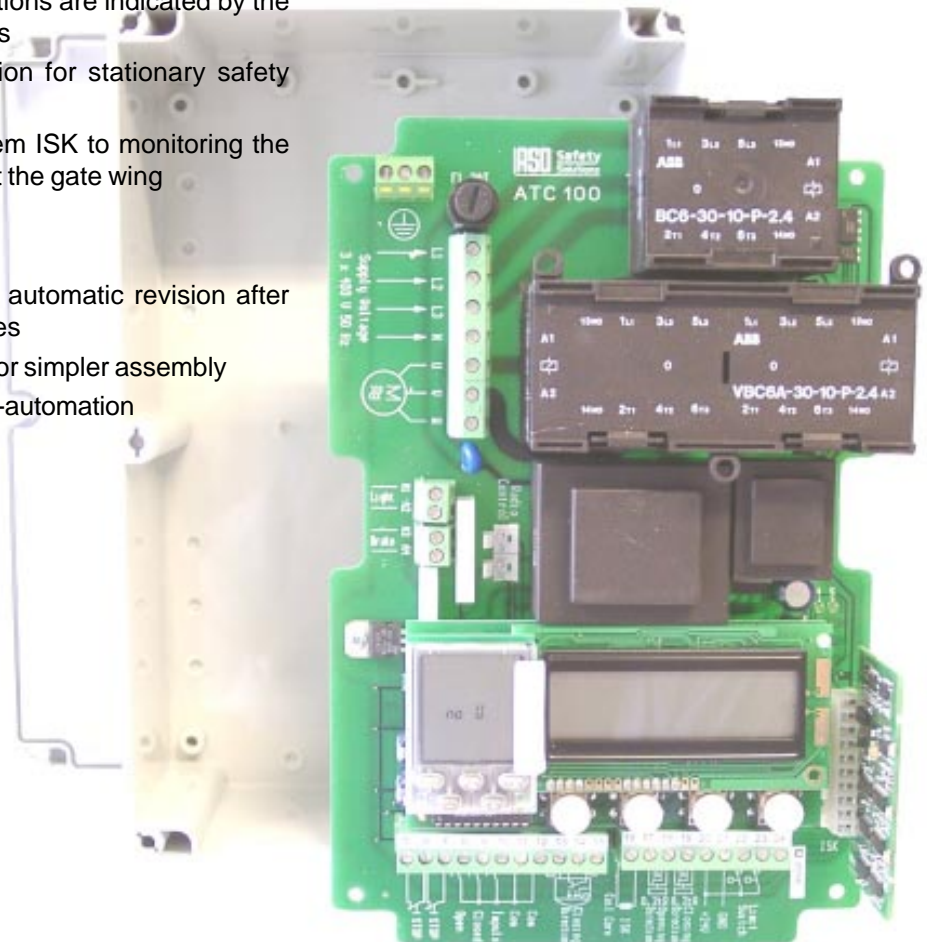

3. System components

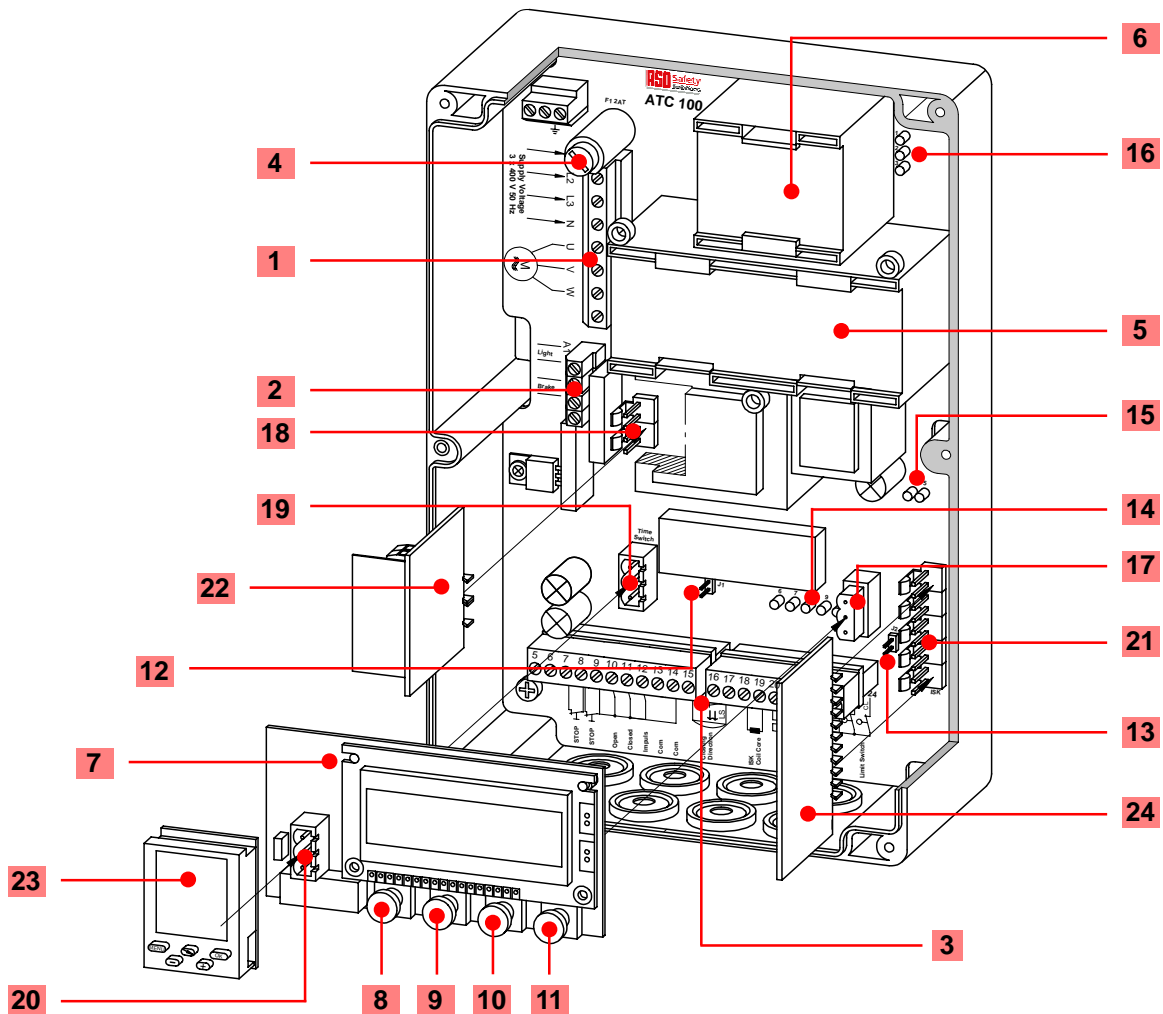

- | | |
|--|--|
| 1 Terminal clamps supply voltage, motor | 14 Led indicator for selftest |
| 2 Terminal clamps light and brake | 15 Led indicator safety contact edges |
| 3 Terminal clamps inputs | 16 Led indicators contactors |
| 4 Fuse 2AT/250V | 17 Socket for ATC 100 control module |
| 5 Reversing contactor | 18 Socket for radio controller |
| 6 Release contactor | 19 Socket for timer |
| 7 Control module | 20 Socket for timer "looped" |
| 8 Menu selection button | 21 Socket for inductive safety system ISK 70-75 |
| 9 Function button | |
| 10 Close (-) button | Optional modules |
| 11 Open (+) button | 22 radio controller |
| 12 Jumper J1 | 23 Week timer |
| 13 Jumper J2 | 24 Inductive safety system ISK 70-75 |

3.1 LED - indicators

Led indicators for the contactors

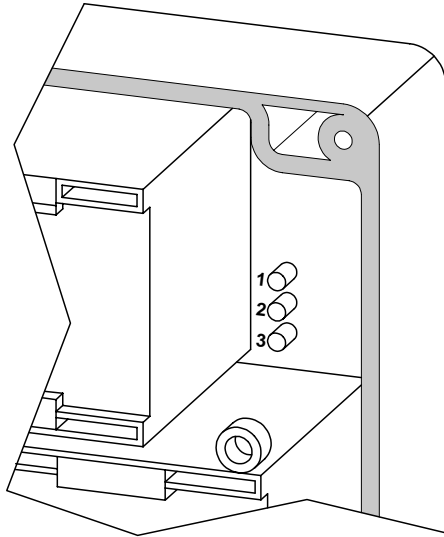

- LED 1** Release contactor switched
- LED 2** Contactor for OPENING direction switched
- LED 3** Contactor for CLOSING direction switched

Led indicator for the safety contact edges

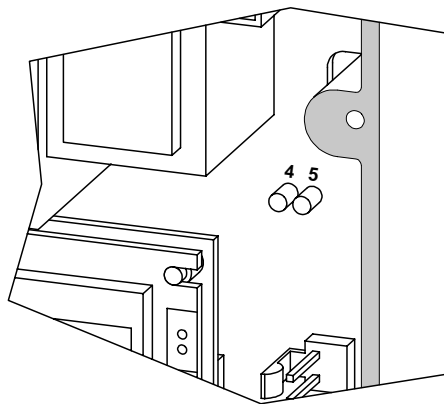

- LED 4** lights, if the safety contact edge(s) for the OPENING direction is (are) OK
- LED 5** lights, if the safety contact edge(s) for the CLOSING direction is (are) OK

Led indicators for the self-test

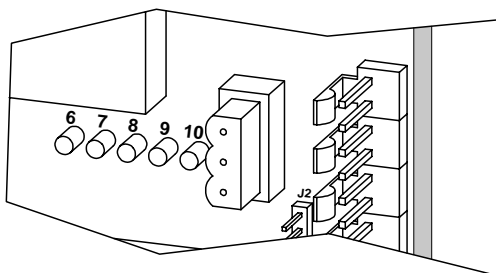

- LED 6** Self-test failing
- LED 7** Performing self-test step1 OPENING direction
- LED 8** Performing self-test step2 OPENING direction
- LED 9** Performing self-test step1 CLOSING direction
- LED 10** Performing self-test step2 CLOSING direction

4. Electrical connection / Functional description



For safety reasons the electrical installation is only to be accomplished from a qualified electrical person.

The opening of the gate-controller is only permitted with switched off power supply. For the disconnection of the power supply a main power switch or the use of a CEE plug is to be planned. The main power switch or the power supply plug must be easily accessible.

The points specified under the section - *Important Safety Notes* - are to be considered.

The close installation of signal- and electric power-lines should be avoided as far as possible.

All lines are to be dimensioned according to the capacity.

For a simply attaching of the individual wires the clamps 5 to 24 are pluggable.

The used stage nipple cable insertion may only cut to the stage, so that the insertion of the cable corresponds to the IP 54 protection against water and foreign objects.

Damaged stage nipples must be exchanged immediately against intact.

Overview connectors

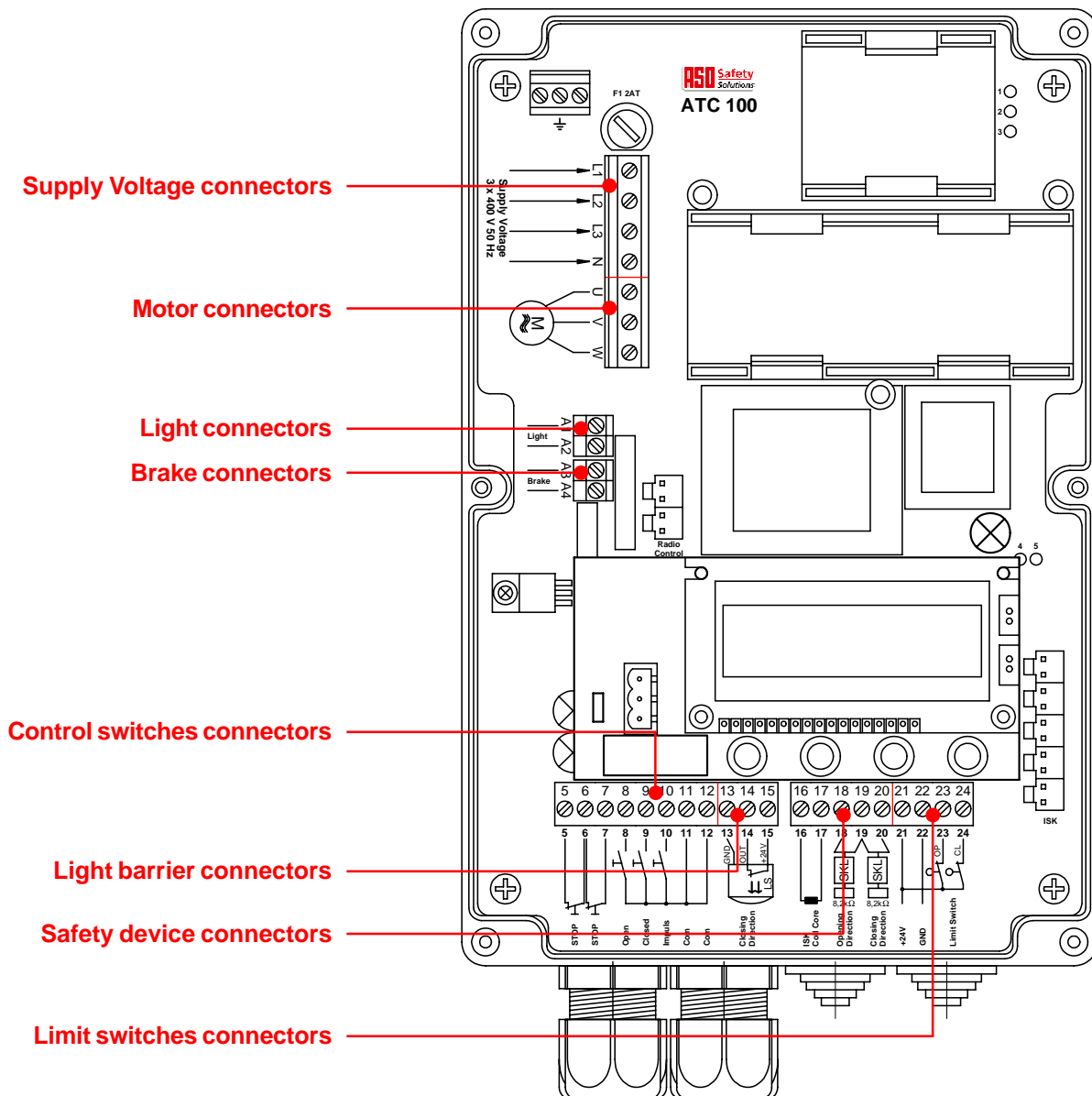

Gate Controller ATC 100

4.1 Mains voltage / Motor connection

The ATC 100 allows the optional connection of 400 V - three-phase motors or 230 V one-phase motors. To the connection diagrams illustrated here the respective connection diagrams of the motor manufacturer are also to be considered. With motors without internal motor protection a suitable motor protection is to be planned. Safety devices of the motor, like temperature rise protection, crank handle switch etc., must be connected to the clamps STOP.

4.1.1 Three-phase motor connection

For the connection of a three-phase motor the supply voltage is to be connected to the clamps L1, L2, L3. For the internal supply voltage of the ATC 100 it is necessary to connect the neutral conductor to the clamp N. The electrical safeguarding of the supply voltage is to be planned external and may have an amount of max. 3 x 10A.

With the initial start-up of the gate pay attention to the rotation direction of the motor (if necessary exchange the connections V and W).

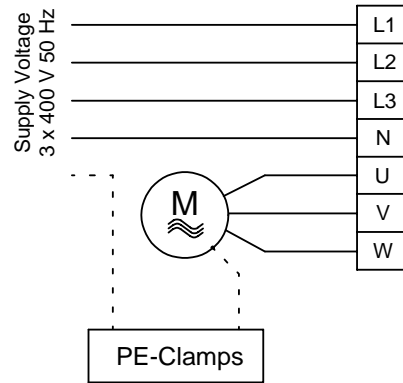

Wiring regulation

In order to keep the safety class, the jackets of this cables, as represented in the drawings, must reach up to the corresponding connectors. **The removing of the jackets to the cable-glands is not permissible.**

After wiring the cable-glands must be tightened firmly.

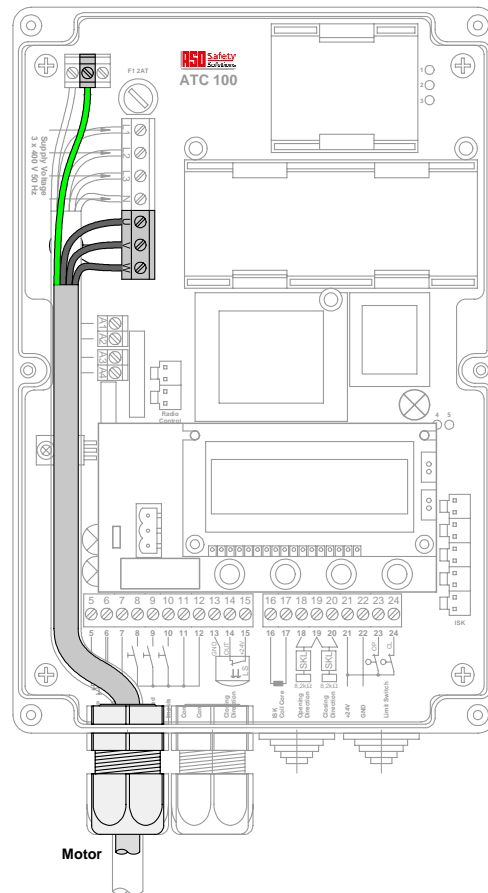
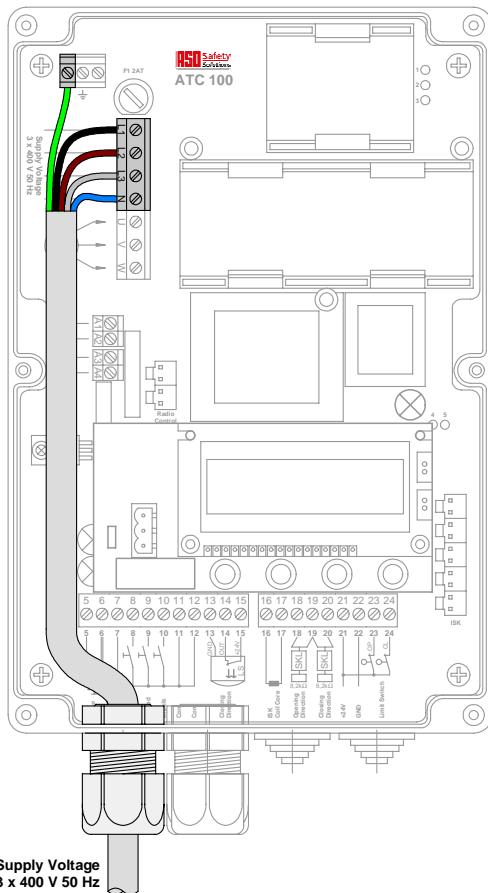

4.1.2 One-phase motor connection

For the connection of a one-phase motor the supply voltage is to be connected to the clamps L1,N. The electrical safeguarding of the supply voltage is to be planned external and may have an amount of max. 10A.

With the initial start-up of the gate pay attention to the rotation direction of the motor (if necessary exchange the connections V and W). Connect the neutral conductor of the motor to the clamp U. Additionally a bridge has to be inserted between L3 and N.

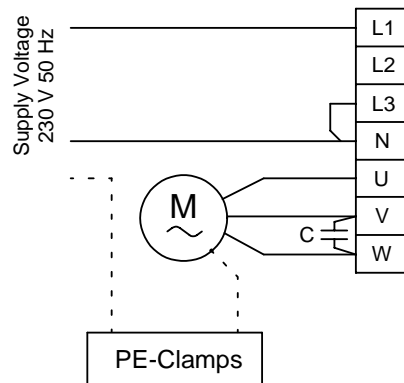

Wiring regulation

In order to keep the safety class, the jackets of this cables, as represented in the drawings, must reach up to the corresponding connectors. **The removing of the jackets to the cable-glands is not permissible.**

After wiring the cable-glands must be tightened firmly.

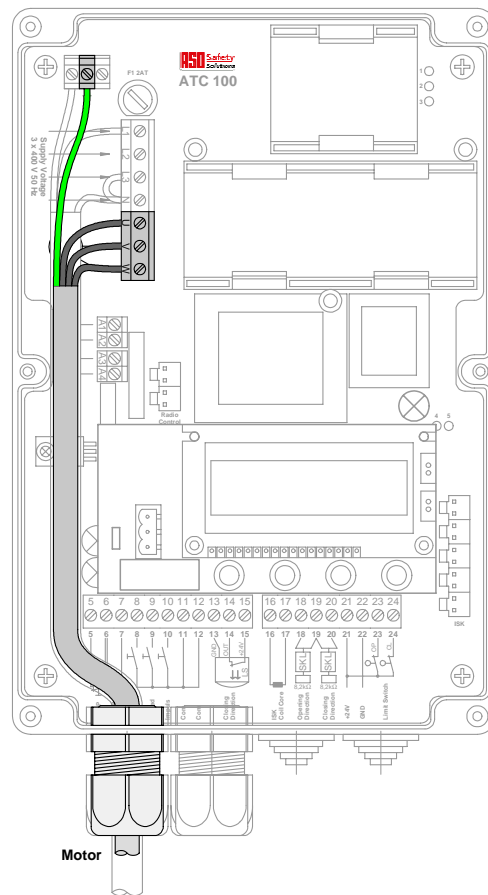
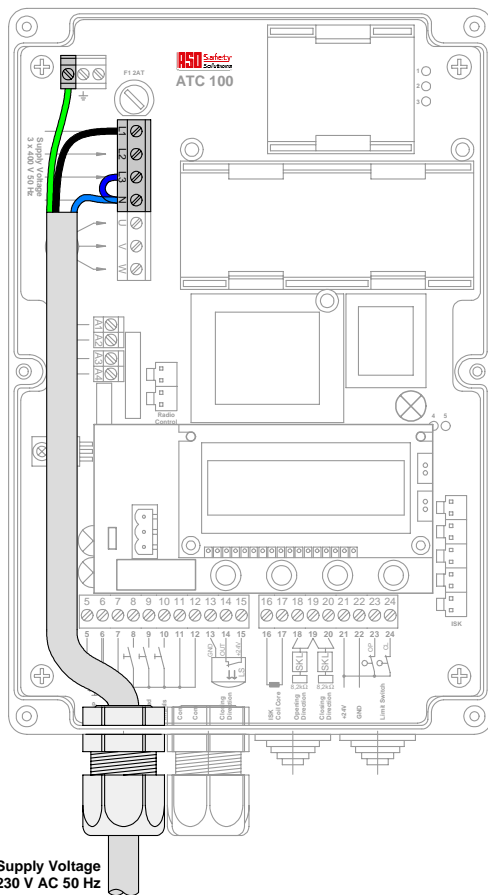

4.2 Relay outputs (potential free)

A warning-light (flashing-, round about light, etc.), which lights or flashes while opening or closing the gate, can be connected to the clamps A1, A2. Furthermore the output for the activation of a light or a brake can be used.

An individual parametrizable brake can be attached to the clamps A3, A4.

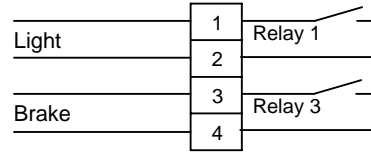

Wiring regulation

If the potential free contacts of the relay outputs are connected to a dangerous voltage, the jackets of these cables must reach up to the corresponding connectors in order to keep the safety class. **The removing of the jackets to the cable-glands is not permissible.**

After wiring the cable-glands must be tightened firmly.

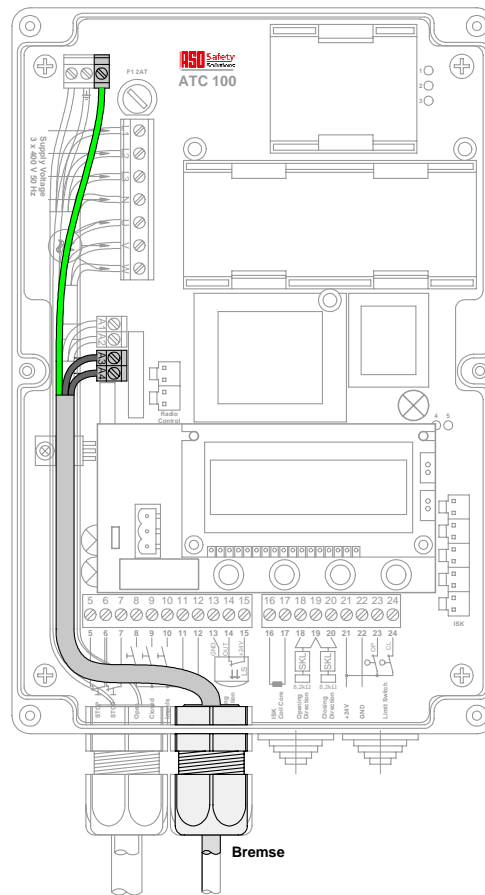
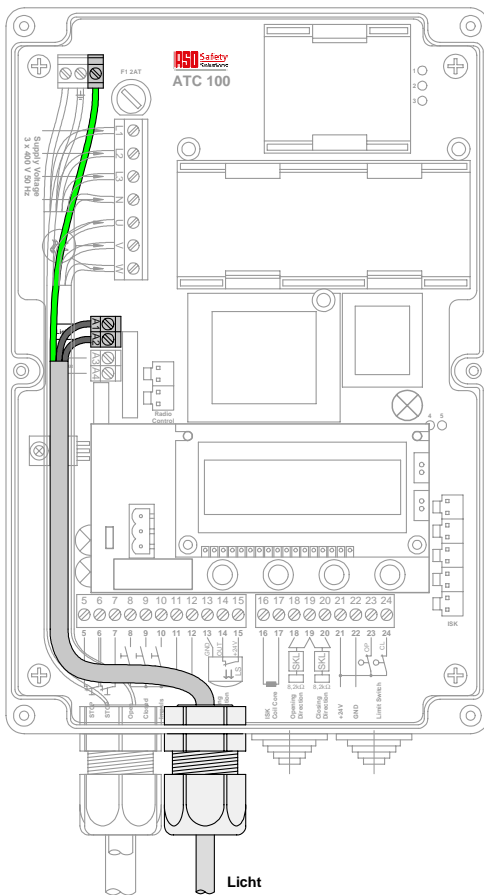

4.3 STOP inputs

The STOP-inputs are inputs without a safety-related-function. They are for the monitoring of STOP-signal generator (e.g. STOP-button etc.).

The two inputs are internally switched in series. If a stop is released, this causes an immediate stop in both directions of travel and the message "STOP" appears in the display. The STOP-chain is active in every program step, except the gate end position. By the STOP-instructions all stored instructions (e.g. automatic closing etc.) are deleted. Therefore a new initial instruction must possibly be given after clearance of the malfunction.

If an input and/or both inputs are not connected they are to be bridged accordingly. If there are more than two STOP-inputs needed the opener circles of the signal generators have to be switched in series.

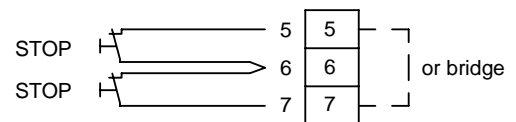

4.4 Control switch inputs

Connect to the clamps 8 to 12 the control switches (normally open contacts) for the Opening, Closing and Impuls. These control switches can be implemented as switches, key-operated push buttons, code lock or extern radio controller.

Depending of the settings for "*Impuls*" the impuls input initializes the instruction sequence "open-stop close-stop ..." and/or "open, close, open ...". In the end positions of the gate the impuls will initiate the corresponding moving of the gate.

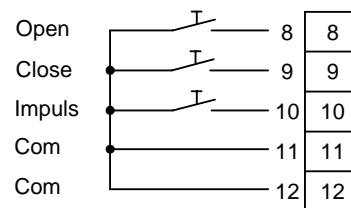

4.5 Light-barrier inputs

Inputs for a light barrier, which is active in the closing movement of the gate. Dependent on the settings an initiation of the light barrier in the closing movement causes a STOP with short or STOP with full reversion. Contrary to the full reversion the automatic closing will be deleted with the short reversion. If several light barriers are installed, the appropriate light barrier contacts are to be switched in series.

If the input is not used the inputs 14, 15 are to be bridged accordingly.

With activation of the "secondary-time" the function for quick closing after crossing the light barrier can be realized in the "automatic-mode". Instead of the adjusted open-time the adjusted secondary-time is used as a new open-time after crossing the light barrier..

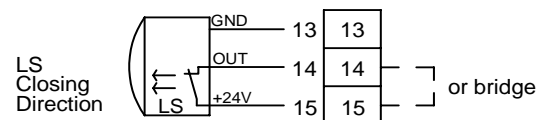

4.6 Safety contact edges connection

Stationary safety contact edges

The direction depending monitoring of the stationary safety contact edges takes place directly on the ATC 100. The contact edges working against the driving direction have no influence to the program sequence. If the automatic closing is activated an actuating of the contact edges will reset the automatic closing till the next start-up signal.

Not used inputs must be terminated with a 8,2 kΩ resistor.

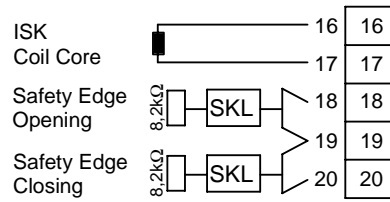

Travelling safety contact edges

The direction depending monitoring of the safety contact edges travelling with the gate (**sliding gates applications**) takes place via the optionally plug-on inductive safety system ISK 70-75 electronic. The contact edges working against the driving direction have no influence to the program sequence. If the automatic closing is activated an actuating of the contact edges will reset the automatic closing up to the next start-up signal. Please take the detailed description and the assembly instruction for the ISK-system from the current ISK documentation.

For gates where no ISK modules is needed (roller-, revolving-, sectional-doors etc.) the function of the ISK-system can be deactivated. For this the jumper J2 is to be bridged.



The installation without safety contact edges and/or without ISK-system may only be used on gate-systems which have their own and to the latest standards confirming safety devices. Gate systems without safety devices may only operated in manual mode to prevent severe injuries. The liability of the manufacturer is terminated with neglect or deliberate abuse.

4.7 Limit switch inputs

The limit switches OPEN (**Limit Switch OP**) and the limit switch CLOSE (**Limit Switch CL**) are monitored permanently and are stringently necessary for the allocation of the actual end position. The limit switches can be implemented e.g. as rolling- or inductive limit switch (normally close contact).

If end position OPEN and end position CLOSE is detected at the same time the program stops. The signal "ERROR end positions" is indicated in the display.

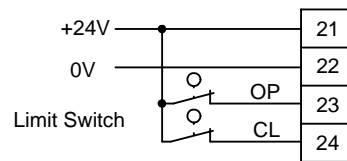

4.8 Power supply output 24 V

For the supply of external consumers the ATC 100 provides a power supply output with 24V DC ±15%.

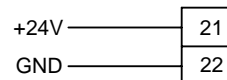

24V DC for ext. consumer
(max. 250 mA)



This 24 V power supply output may be loaded with **max. 250 mA..**

5. Plug-on modules

All sockets on the ATC 100 are particularly intended for the described plug-on modules. The inserting of other plug-on modules can damage or destroy the ATC 100 controller as well as the plug-on modules. The plug-on modules may be inserted and/or taken off only in switched off condition of the control. The respective plug-on modules can be only inserted on the appropriate socket of the ATC 100 and only in one direction. Taking off a plug-on module from it's socket is facilitated by mutual tilting of the appropriate module.

5.1 Control module

The pluggable control module serves the parametrization, the visualization of the control sequences and the diagnosis in case of an error.

The controller can be operated either with or without the control module. The operability of the controller is identical in both cases. With this the pluggable control module offers an effective protection from manipulation or unauthorized access.

The function range of the controller is not limited by the missing control module.

5.2 Additional modules (optionally available)



Please pay attention to the individual documentations of the additional modules.

5.2.1 Inductive safety system ISK 70-75

With the additional module ISK 70-75 (**sliding gate application**) up to two travelling safety contact edge circuits can be connected and monitored direction depending. These safety contact edges at the gate wing are monitored by the inductive safety system wearout-free and without mechanical stress. The contact edge working against the direction has no influence to the program sequence. The semiconductor outputs are linked with the soft- and hardware of the control.



The installation on a sliding gate application without ISK-system may only be used on gate-systems which have their own and to the latest standards confirming safety devices. Gate systems without safety devices may only operated in manual mode to prevent severe injuries.

The liability of the manufacturer is terminated with neglect or deliberate abuse.

5.2.2 Time switch ZU 3

With the integration of the pluggable time switch a day-dependent automation of the gate system is possible. The time switch contains the following functions:

- Up to 8 program sequences per day (Rush-Hour)
- Program sequences can be copied to different days
- smallest switching time is 1 minute
- Digital display of clock-time and weekdays
- Summer-/winter time conversion alternatively by hand or automatically

5.2.3 Radio control

The single-channel radio controller works with 433MHz. Depending of the settings "*Impuls*", the radio-impulse initializes the instruction sequence "Open-Stop- Close-Stop ..." resp. "Open,Close,Open ...". In the end positions of the gate the radio impulse will initiate the corresponding moving of the gate.

• Adjusting the radio receiver

- Set the DIP-switch of the radio receiver to individual code
- Select the key allocation of the receiver:

1-Instruction hand-transmitter:

insert jumper J1 und J2

2-Instruction hand-transmitter:

insert only jumper J2 → first (left) key selected

insert only jumper J1 → second (right) key selected

3-Instruction hand-transmitter:

insert jumper J1 and J2 → first key selected

insert only jumper J2 → second key selected

only jumper J1 inserted → third key selected

4-Instruction hand-transmitter:

insert jumper J1and J2 → first key selected

only jumper J2 inserted → second key selected

only jumper J1 inserted → third key selected

no jumper inserted → fourth key selected

• Adjusting the hand transmitter

- Adjust the DIP-switch of the hand-transmitter accordingly to the settings of the radio-receiver.

6. Program settings

In this description of the settings a maximum configuration of the system is presupposed. If a component is missing in the system the appropriate subfunction of the controller is inactive (poss. insert bridge).

The display of the ATC100 control module is implemented as a two-line display. The upper line generally indicates the mode of operation. The second line indicates the selected function depending upon the mode of operation. In the mode automatic the conditions of the gate system are displayed here.

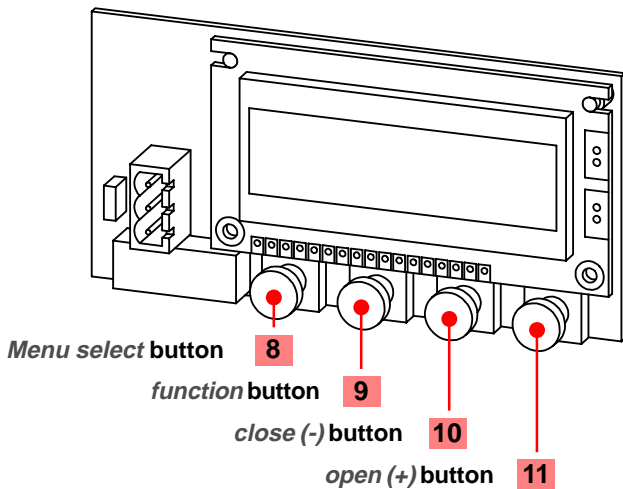

With the button **MENU SELECT** 4 modes of operation can be adjusted. By actuating the button (approx. 2 sec.) the individual modes of operation can be selected in sequence.

- AUTOMATIK**
- TOTMANNBETRIEB**
- EINGABE**
- DIAGNOSE**

In the different modes of operation the buttons **CLOSE(-)** and **OPEN(+)** have different functions.

6.1 AUTOMATIC

The button **CLOSE(-)** and **OPEN(+)** have no function.

6.2 MANUAL MODE

In the manual mode the drive can be opened with the button **OPEN (+)** and be closed with the button **CLOSE(-)**. (with faulty or missing safety devices no manual mode operation is possible).

6.3 ADJUST

To change the ATC 100 settings the button **MENU SELECT** and the button **FUNCTION** have to be pressed at the same time (approx. 2 sec.) to reach the adjust-menu.

The parameter to be changed can be selected by pressing the button **FUNCTION** (the individual parameters are indicated "rolling wise"). The appropriate selected parameter can be adjusted by pressing the button **OPEN(+)** or **CLOSE(-)**.

If all parameters are adjusted in this way, press the buttons **MENU SELECT** and **FUNCTION** to leave the adjust-menu. If no button is actuated in the adjust-mode for 90 sec., all adjusted parameters will be saved and the controller switches to the **MANUAL MODE**.

With the switch **MENU SELECT** the mode "AUTOMATIC" can be selected again.

The parameters appear in the following sequence and have the functions as described.

• LCD

Deutsch / English / Francais **Pre-setting: Deutsch**

Language setting for control module.

• Run Time

1 up to 240 sec.

Pre-setting: 120 sec.

In order to protect drive and gate mechanics the run time is monitored during the opening- and closing phase. If the appropriate limit switch is not reached in the programmed time the controller stops. If this happens the control module displays ERROR run time. The adjusted run time should be selected 10 sec. longer than the maximum gate run time.

• OPEN TIME

0 up to 600 sec.

Pre-setting: 0 sec.

The counting of time begins after reaching the limit-switch OPEN. After expiring this time the advance warning time begins followed by the automatic closing of the gate.

The automatic closing is deactivated if the opening time is adjusted to 0.



Automatic closing can also be prevented on the hardware side. For this the **Jumper 1** is to be removed.

• PRE-WARN. (Pre-Warning)

0 up to 120 sec.

Pre-setting: 0 sec.

(Applicable only in closing-movement)

With setting 0 the gate starts immediately after a moving instruction. With adjusted time the pre-warning is started and the gate only starts to run after expiration of the adjusted time.

- **REV. TIME (Reversal-Time)**

0,1 up to 2,0 sec. *Pre-setting: 0,5 sec.*

Delay-time before changing moving-direction.

- **2ND Time**

0 up to 60 sec. *Pre-setting: 0 sec.*

With activation of the "2nd time" the function of quick closing after crossing the light barrier can be realized in the "automatic closing" mode. Instead of the adjusted open time the 2nd time is used as the new open time after crossing the light barrier.

- **Relay Light**

MOD 1,2,3,4 or 5 *Pre-setting: MOD 1*

Relay output to control a light, a warning light or a brake at the gate.

MOD 1: Continuous light funct. as long as gate is in motion

MOD 2: Light control after opening-instruction for 3 min.

MOD 3: Brake function, relay switched if gate stops

MOD 4: Failure light, lights so long as the failure is present

MOD 5: Failure light, like MOD 4 however with 20 sec. switch -off delay

- **EDGE CL (Safety contact edge closing direction)**

MOD 1 or 2 *Pre-setting: MOD 2*

This parameter specifies the reaction of the controller if the safety contact edge is activated in the closing movement.

MOD 1: STOP plus short reversion 1,5 sec.

MOD 2: STOP plus full reversion

- **EDGE OP (Safety contact edge opening direction)**

MOD 1 or 2 *Pre-setting: MOD 1*

This parameter specifies the reaction of the controller if the safety contact edge is activated in the opening movement.

MOD 1: STOP plus short reversion 1,5 sec.

MOD 2: STOP plus full reversion

- **LIGHT B. CL (Light barrier closing movement)**

MOD 1 or 2 *Pre-setting: MOD 2*

This parameter specifies the reaction of the controller if the light barrier is interrupted (closing movement).

MOD 1: STOP plus short reversion 1,5 sec.

MOD 2: STOP plus full reversion

- **BRAKE:**

MOD 1 or 2 *Pre-setting: MOD 2*

This parameter specifies how the motor-brake is controlled.

MOD 1: Relay is activated if motor stands

MOD 2: Relay is activated if motor runs

MOD 3: Relay is activated for 3 sec. if motor stands

MOD 4: Relay is activated for 3sec. if motor runs

- **IMPULS MOD**

MOD 1 or 2 *Pre-setting: MOD 1*

Specifies the function of the impulse-input.

MOD 1: open/stop/close/stop ...

MOD 2: open/close/open ...

- **TIME SWIT. (Time Switch)**

MOD 1 or 2 *Pre-setting: MOD 1*

Specifies the function of the time switch.

The operation of the gate is at anytime possible because the clock only prevents automatic closing.

MOD 1: Opening of the gate by opening-button, after that the clock keeps the gate open.

MOD 2: Opening of the gate by clock, after that the clock keeps the gate open.

6.4 DIAGNOSIS

In the mode diagnosis in each case 2 inputs are indicated in the display as a check of the conditions. The inputs are indicated as full-text with associated ON or OFF. Using the switches **open (+)** and **close (-)** changes to the next pair of inputs.

In case of malfunction all inputs can be checked very easy by this indication without using measurement instruments. By a further pressure of the button **FUNCTION** the next mode of operation is reached.

Indicated operating conditions

EDGE OP (Safety contact edge opening direction)

Displays the operating conditions of the safety contact edges for the opening direction.

EDGE OP On

Safety contact edges are wired and no operation or malfunction is present.

EDGE OP Off

Safety contact edges are not wired or an operation or a malfunction is present.

EDGE CL (Safety contact edge closing direction)

Displays the operating conditions of the safety contact edges for the closing direction..

EDGE CL On

Safety contact edges are wired and no operation or malfunction is present.

EDGE CL Off

Safety contact edges are not wired or an operation or a malfunction is present.

AUTO RUN (automatic closing of the gate)

Displays whether the automatic closing of the gate is activated or not. The automatic closing of the gate can be disabled over the Jumper J1.

AUTO RUN On

Automatic closing activated

AUTO RUN Off

Automatic closing not activated

Light B. CL

Displays the operating conditions of the passage light barrier for the closing movement.

Light B. CL On

Passage light barrier installed and light beam is not interrupted.

Light B. CL Off

Passage light barrier not installed or light beam is not interrupted.

LIMIT SW OP (limit switch for opened gate)

Displays the operating conditions of the limit switch for opened gate position.

LIMIT SW OP On

Limit switch wired correctly and is not operated

LIMIT SW OP Off

Limit switch is not wired correctly or is operated

LIMIT SW CL (limit switch for closed gate)

Displays the operating conditions of the limit switch for closed gate position.

LIMIT SW CL On

Limit switch wired correctly and is not operated

LIMIT SW CL Off

Limit switch is not wired correctly or is operated

SWITCH OPEN (Switch/button for OPEN-instruction)

Displays the operating condition of the switch/button for the OPEN-instruction.

SWITCH OPEN On

Switch/button is operated

SWITCH OPEN Off

Switch/button is not operated

SWITCH CLOSE (Switch/button for CLOSE-instruction)

Displays the operating condition of the switch/button for the CLOSE-instruction.

SWITCH CLOSE On

Switch/button is operated

SWITCH CLOSE Off

Switch/button is not operated

STOP

Displays the operating condition of the stop chain. To the STOP chain belongs e.g. stop tracer, emergency stop pushbutton etc., which are switched into row.

STOP On

Stop-chain is wired correctly respectively no device is operated or has triggered.

STOP Off

Stop-chain is not wired correctly respectively a device is operated or has triggered.

IMPULS

Displays the operating condition of the impuls switch/button

Impuls On

Switch/button is operated

Impuls Off

Switch/button is not operated

TIME SWIT.

Displays the operating condition of the time switch.

TIME SWIT. On

Time switch gives an instruction to the controller.

TIME SWIT. Off

Time switch doesn't give an instruction to the controller.

CYCLE

The counted cycles which are executed so far by the controller are indicated here.

7. Jumper settings:

With the 2 jumpers on the board general functions can be adjusted.

- **Jumper J1: automatic closing**

J1 open: automatic closing deactivated

J1 bridged: automatic closing activated

- **Jumper J2: ISK-Safety system**

J2 open: ISK-Safety system activated

J2 bridged: ISK-Safety system deactivated

8. Article numbers

ATC100 compl. with enclosure, control module 302030

ATC100 only electronic without control module 302031

Control modul for ATC100 302033

Enclosure for ATC100 302034

Plug-on module ISK 70-75 204160

Plug-on module ISK 70-75 204162
in the set with SPK9 and SPK 12

Time switch ZU 3 550103

Radio receiver HE single channel 515110
with antenna

Hand transmitter HE single-channel 514001

Hand transmitter HE dual-channel 514002

Hand transmitter HE quad-channel 514004

9. Enclosure

ABS-Enclosure with cable glands and stage nipple cable insertions.

9.1 Mounting of the enclosure

Before mounting the controller is to be examined for possible transportation or other damages. If the electronic or the enclosure is damaged the controller may not be installed or taken in operation.

After removing the cover the enclosure can be fixed with four screws.

Mounting on walls:

Wood screws 4x40mm with 6mm dowel

Mounting on the gate:

Tapping screw 4x20mm or machine screw M4x20mm

The ATC 100 is to be fastened professionally with all four screws to a suitable mounting place with even underground.

The ATC100 is designed for a vertical mounting.

In order to prevent infiltrating humidity through the cable glands, the enclosure should be installed in such a way that the cable glands point downwards.

The weight of the controller of approx. 1,8kg should be absolutely considered with the choice of the mounting.

9.2 Enclosure dimensions

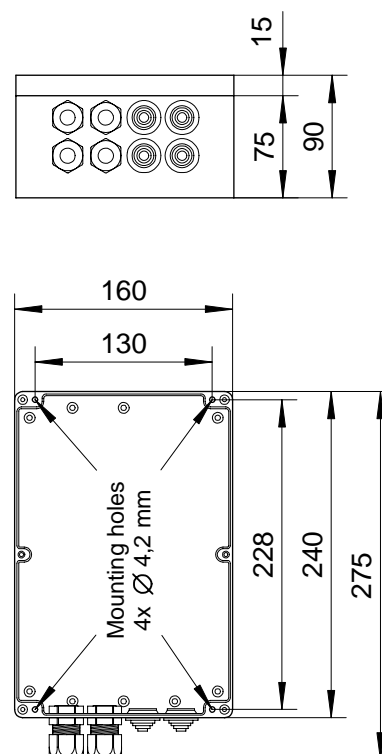

10. Technical data

• Supply voltage

U_E 3 x 400 V 50/60Hz main power supply for three-phase drives

U_E 230 V 50/60Hz main power supply for one-phase drives

$I_E / I_{E\max}$ 65 mA / 107 mA current consumption

P / P_{\max} 15 VA / 24,5 VA power consumption

The maximum values are valid for the maximum configuration of the controller and the maximum supply of external 24V components.

• External safeguarding

F_B max. 10A

• Internal safeguarding

F_i T 2A / 250 V glass tube fuse
5x20mm

• Supply outputs 24 V DC

$U_{\text{Out}24V}$ 24 V DC \pm 15%

$I_{\text{Outmax}24V}$ 250 mA

$P_{\text{Outmax}24V}$ 6 W

To guarantee the correct function of the controller the listed maximum values may not be exceeded in any case.

• Motor reversing contactor

$P_{\text{Smax}230V}$ 2,2 KW max. contactor output with 230 V one-phase drives

$P_{\text{Smax}400V}$ 4KW with 400 V three-phase drives

• Relays

U_{REL} 250 V~ max. switching voltage

I_{REL} 2,5 A~ max. switching current

• Switching times Safety device

T_A \leq 25 ms STOP initiated \rightarrow contactor open

T_A \leq 30 ms ISK initiated \rightarrow contactor open

• Protection class

IP 54 Enclosure with cable glands/stagenipples

• **Weight** 1,8 kg

• **Temperature range** -10° to +55° C

• **Store temperature** -20° to +70° C

• Approvals

EN 12453 - "Safety in use of power operated doors/gates"

EN 12978 - "Safety devices for power operated gates"





Antriebs- und Steuerungstechnik
Am Garock 8 • D-33154 Salzkotten
Tel.: 0 52 58/93 27-0 • Fax: 0 52 58/34 48
www.asogmbh.de • e-mail: info@asogmbh.de

Technical Data Version 1.5:
Stand 26.08.2005

Subject to change without prior notice