

GB

TECHNICAL SPECIFICATIONS

Four-channel AM 433.92 MHz frequency **Rolling Code Receiver**, to be mounted on the edge of the automation's control board. May be paired with **ATOMO** series CAME transmitters with up to 500 units. ABS outdoor container with IP54 protection level.

Equipped with an internal display. Together with Rolling Code technology, it allows quick transmitter memorisation (max 500) and an enduring, easy system maintenance (deleting/re-setting, adding or modifying) It also includes a memory card (Memory Roll) to make a back-up copy of all the memorised transmitters.

N.B. All the operations of system programming and management may be carried out also by personal computer with the related software.

The memory roll works with 12 or 24V AC/DC
Output functions:

- OUT1 in single stable or bistable mode (see pg. 3)
- OUT2 in single stable mode with adjustable timing from 1 to 300 seconds (see pg. 3)
- OUT3 and 4 in normal single stable mode

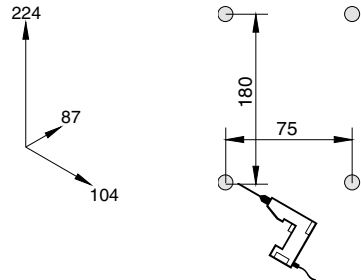
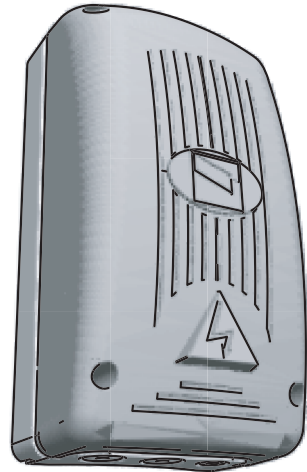

N.B. – The receiver must always be equipped with an aerial.

- Do not install more than one receiver at a distance of less than 4-5 m from each other to avoid function defects.

- **It is a good idea to set the aerial as high from the ground as possible and far from metallic structures and in reinforced concrete.**

RBE4RC MOTHERBOARD

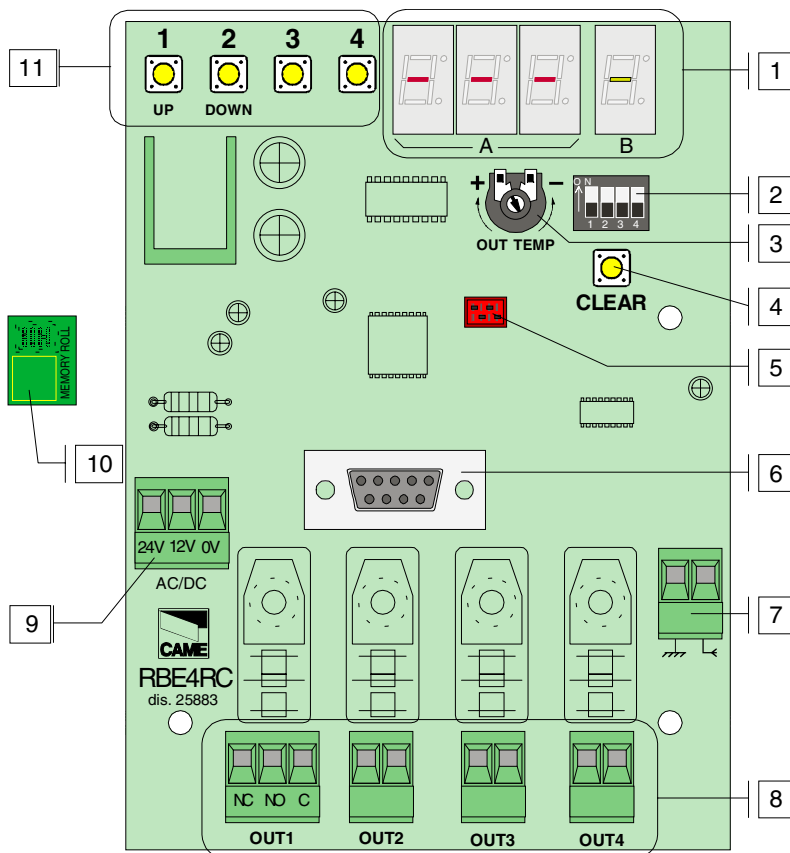

MAIN COMPONENTS

1. Programming display
2. 4-way dipswitch
3. OUT2 relay adjustment trimmer
4. Re-set key
5. Memory Roll card connector
6. RS232 connector for connection to the PC
7. Antenna-connection terminal block
8. Devices-connection terminal boards to command
9. Terminal boards for 12/24V AC/DC power supply.
10. Memory Roll
11. Programming keys

FUNCTION SELECTOR

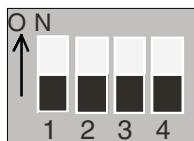

- 1 and 2 Pprogramming and maintenance dips.
See pages ...
- 3 ON **Bistable** OUT1 relay
3 OFF **Single stable** OUT1 relay
- 4 Not used

TRIMMER ADJUSTMENT

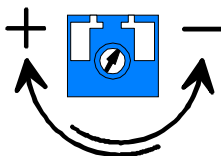

- MINIMUM single stable relay activation time adjustment on output OUT2: **1 second**
- MAXIMUM single stable relay activation time adjustment on output OUT2: **300 seconds**

PROGRAMMING/MAINTENANCE INDEX

- General notes - <i>read carefully</i>	pag. 4
PROG A - Memorises the 1 st transmitter (TX Master)	pag. 5
PROG B - Memorises subsequent transmitters	pag. 6
PROG C - Controls various outputs simultaneously	pag. 7
PROG D - Prepares a 2 nd TX Master	pag. 8
PROG E - Changes password	pag. 9
PROG F - Saves the program on the Memory Roll	pag. 10
MANU A - Adds transmitters	pag. 11
MANU B - Deletes transmitters	pag. 12
MANU C - Inhibits a transmitter's keys	pag. 13
MANU D - Deletes the entire programming	pag. 14
MANU E - Retrieves programming from the Memory Roll	pag. 15

GENERAL NOTES

The first memorised transmitter will be automatically recognised by the card as the Master transmitter (and inserted in the memory's first location).

The TX Master will be the system's main programming and maintenance "agent". It is therefore necessary that it be kept by the person in charge of the management of the automation connected to the receiver.

To this purpose, the receiver set includes a red four-channel transmitter for the TX Master's use.

To facilitate the management of the system, at the end of the booklet there is a section called "USER'S FILE" with a grid in which to write down the name of the user for each transmitter; therefore please keep this booklet together with the TX Master.

Viewer A shows the transmitter's numerical location in the receiver's memory (500 transmitters can be memorised, including Masters); this location unequivocally identifies transmitters.

During maintenance/programming operations, **Viewer B** indicates one of the receiver's four OUT outputs. However, during normal operation it indicates the transmitter channel/key.

Flashing means that no transmitter has been memorised on that output.

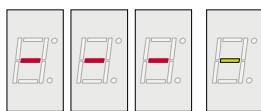

A B

Visors in stand by with
powered board

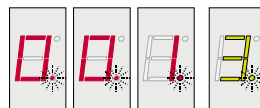
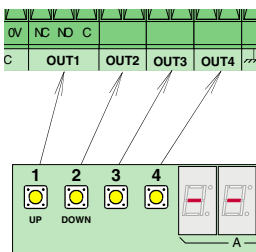

Flashing dots on the viewers means that the memory location has been reached for the TX Master (the 1st is in location 001).

Additionally, the viewers guide the operator during the execution of the procedures during programming/maintenance operations.

PROG A - Memorises the 1st transmitter (TX MASTER)

FIRST BASIC SYSTEM PROGRAMMING OPERATION. THIS PROCEDURE ACTIVATES THE BOARD, WHICH WOULD OTHERWISE REMAIN INACTIVE.

PROCEDURE

A Press the receiver's button 1 until /Sto/ appears on viewer A and output /1/ on viewer B;

B press the Master transmitter's P1 key until the messages disappear.

Repeat A and B for each of the receiver's buttons and corresponding TX Master buttons, that is, buttons 2, 3 and 4 respectively with keys P2, P3 and P4.

C Verify the TX Master's programming by pressing its keys in sequence: the succession of displays should coincide with the one illustrated.

A

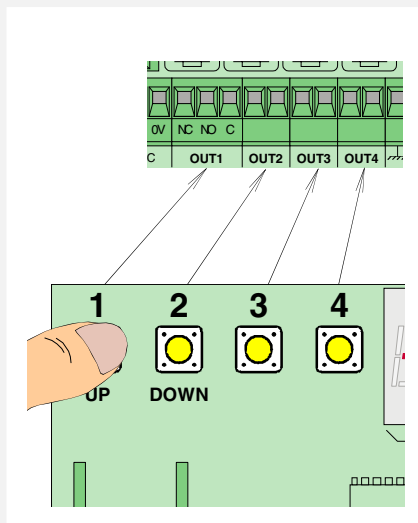

ENGLISH

C

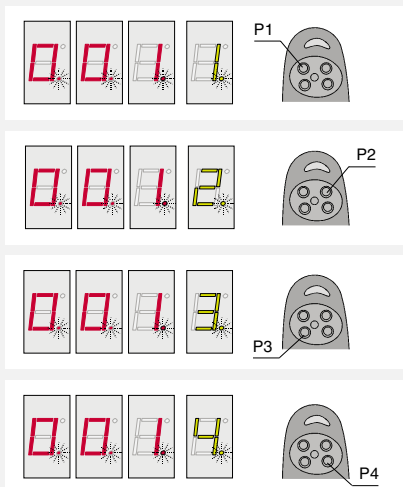

B

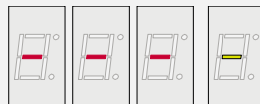
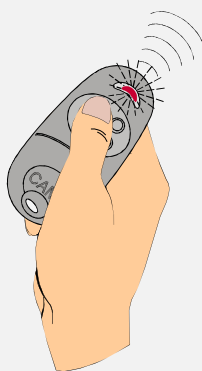

PROG B - Memorises subsequent transmitters

AFTER MEMORISING THE TX MASTER, PREPARE ALL THE AVAILABLE SYSTEM TRANSMITTERS FOR QUICK MEMORISATION. THE FOLLOWING PROCEDURE IS ALSO VALID FOR SUBSEQUENT TRANSMITTER ADDITIONS*

PROCEDURE

A Press the TX Master key for the output that is to be activated (10") until /Sto/ + [linked output number] appears on the viewers and (after another 5") the transmitter's LED indicator remains with its light on;

B within 20", press the corresponding key on the memory transmitter: the messages on the viewers flash. Proceed this way with all the memory transmitters for that output.

C Press (within 20") a new TX Master key: the message changes, indicating the new key/output on viewer B;

D repeat step B with the corresponding transmitter key.

* N.B. see also pg. 11 of the USER'S FILE

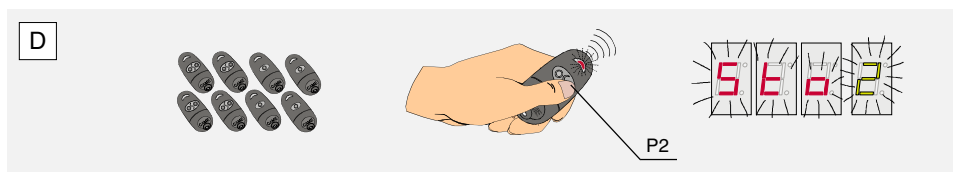
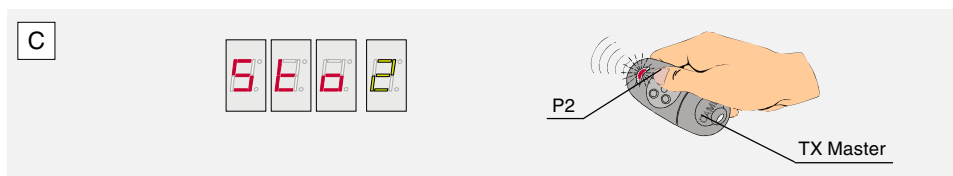
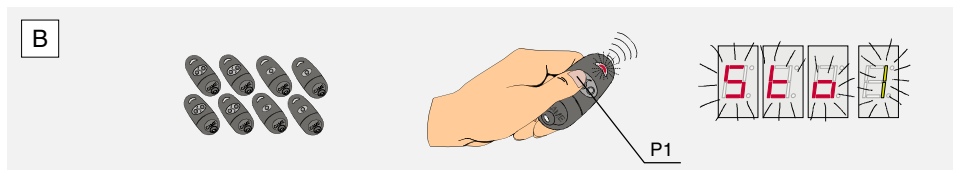
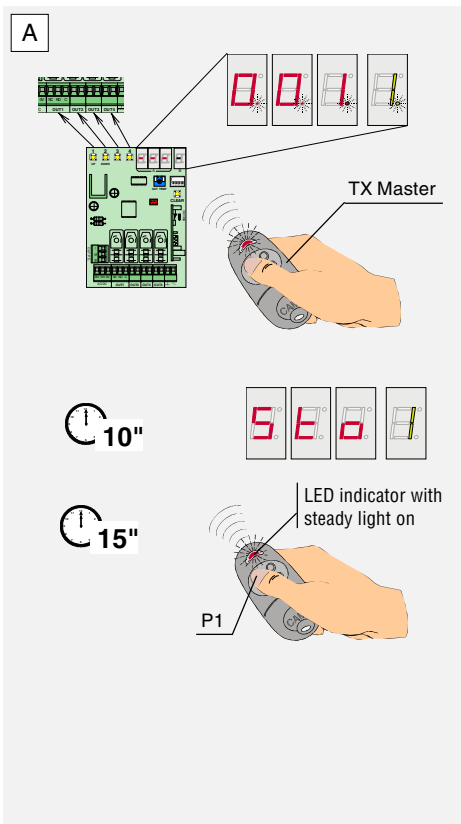

PROG C - Controls various outputs simultaneously

IF, FOR EXAMPLE, YOU WISH TO LINK THE SIMULTANEOUS ACTIVATION OF THE FACILITIES CONNECTED TO OUT1 AND OUT2 (LINKED SEPARATELY ON THE TX MASTER'S P1 AND P2 KEYS) TO A TRANSMITTER'S P1 KEY, PLEASE PROCEED IN THE FOLLOWING MANNER:

PROCEDURE

A Press the TX Master P1 key (10") until /Sto/ + /1/ appears on the viewer and (after another 5") the transmitter's LED indicator remains with its light on;

B within 20", press the P1 key of the transmitter to be memorised: the message on the viewer flashes. Proceed this way with all the transmitters to be memorised for that output.

C Press (within 20") the TX Master P2 key: the message changes, indicating the /2/ key/output on viewer B.

D repeat step B using the P1 key.

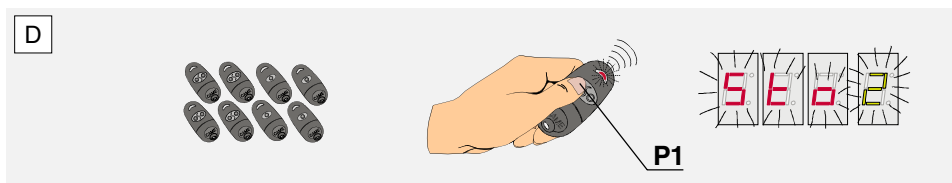
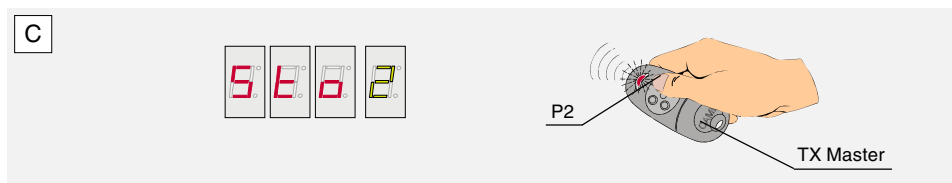
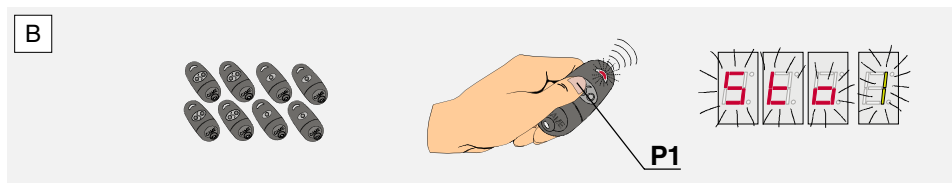
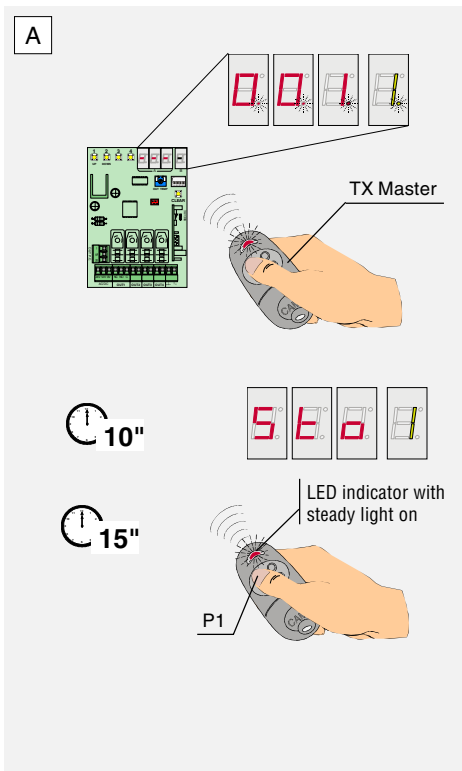

PROG D - Prepares a 2nd TX MASTER

IF NECESSARY, IT IS POSSIBLE TO CONFIGURE ANY OF THE ALREADY MEMORISED TRANSMITTERS AS A SECOND TX MASTER.

PROCEDURE

A Press any key of the transmitter to be configured as a second Master and read the memory location occupied on viewer A;

B set dip 2 to ON (viewer A shows the first free memory location, viewer B a flashing /S/);

C select the transmitter location as shown from point A with the UP and DOWN keys;

D press any of the first TX Master's keys, (10") until the /M/ message, including periods, appears and flashes on viewer B;

E re-set dip 2 to OFF.

N.B. It is possible to configure a single TX Master in addition to the first one; if the procedure is repeated with another TX, it will automatically substitute the previous one.

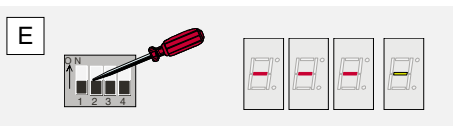
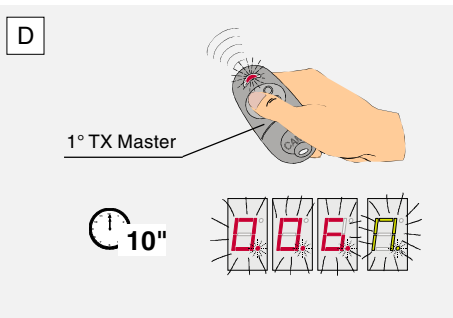
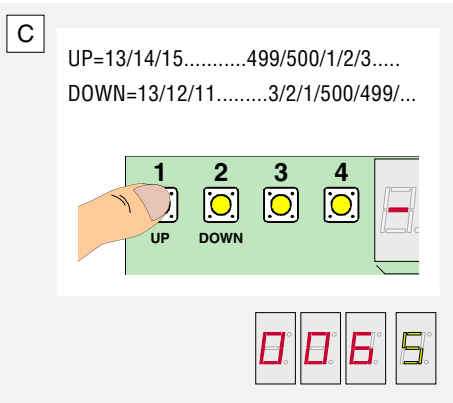
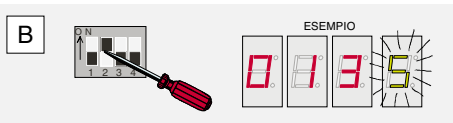
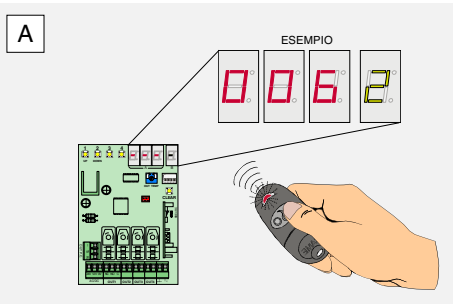

PROG E - Changes password

IF FOR ANY REASON IT BECOMES NECESSARY TO RE-SET THE PROGRAMMING DONE (SEE MANU D), THERE IS A SECURITY **PASSWORD PRE-SET TO 123** BY CAME THAT CAN BE CUSTOMISED.

PROCEDURE

A Set dip 1 and 2 to ON: $|001| + |c|$ appears on the viewers

B press the CLEAR key: the writing changes to $|000| + |c|$ and the "c" flashes);

C select the existing password (the one pre-set , for example) with the UP and DOWN keys;

D press the CLEAR key (the entire message $|123| + |c|$ flashes) and then, within 5", press key 4 (the message changes to $|000| + |c|$ and the "c" flashes);

E set the new password with the UP and DOWN keys;

F press the CLEAR Key (the letter $|m|$ appears without flashing on viewer B), and re-set the dip 1 and 2 to OFF.

N.B. The new password can be made up of a single digit. Copy it in the appropriate space in the USER'S FILE

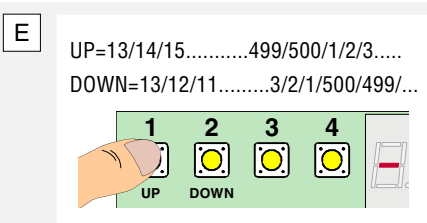
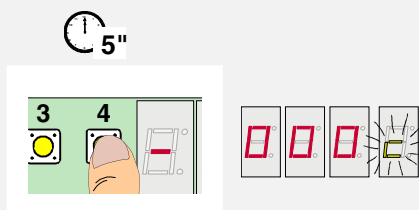
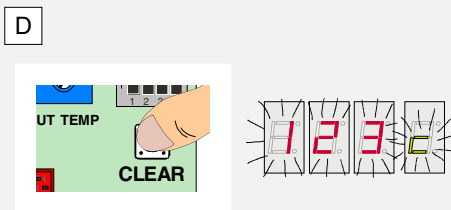
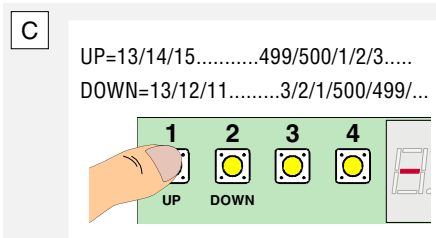
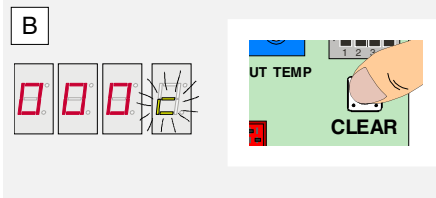
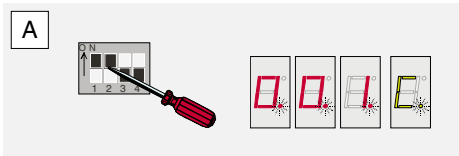

select a new password (a number from 1 to 500)

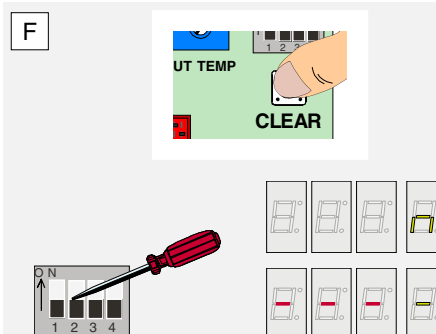
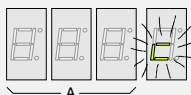

PROG F - Saves the program on the Memory Roll

UPON COMPLETION OF THE SYSTEM'S INSTALLATION, USE THE MEMORY ROLL TO SAVE PROGRAMMING DONE ON THE RECEIVER.

PROCEDURE

- A Insert (*) the Memory Roll in the corresponding connector;
- B first press and keep pressed any TX Master key and then key 2 on the receiver; release both only when (10^m) the /U/ message appears on viewer B;
- C remove (*) the Memory Roll and file it.

 *** WARNING!** Prior to any board connecting or disconnecting operation, turn off the power to the system.

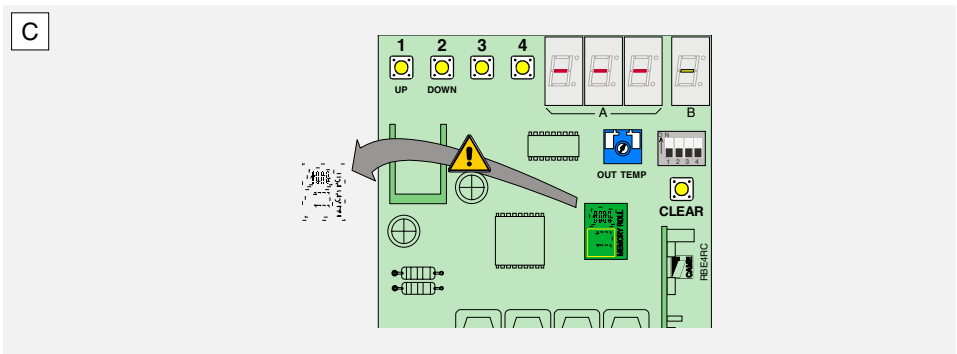
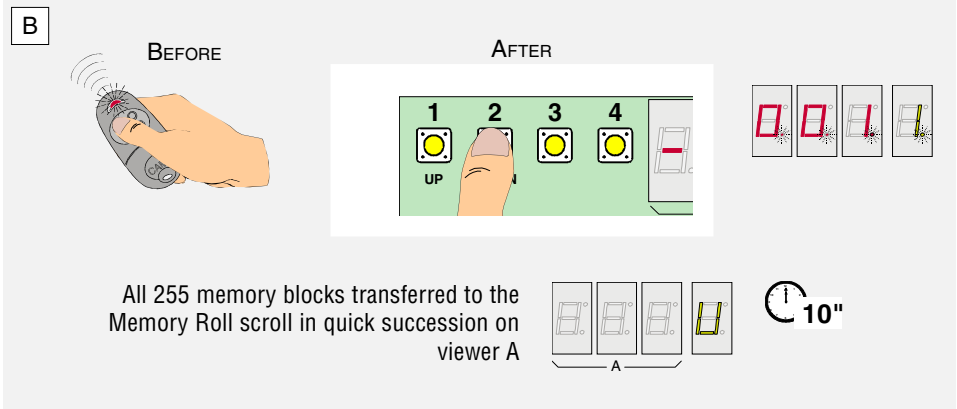
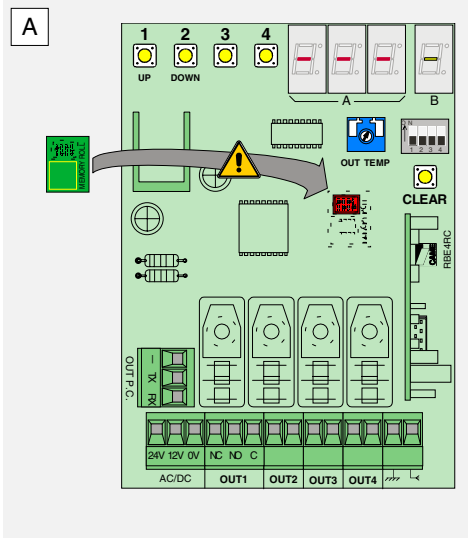

MANU A - Adds transmitters

THERE ARE TWO WAYS TO ADD TRANSMITTERS:
 - ADD THEM IN SEQUENCE, THAT IS, MEMORISE THEM ON THE FIRST FREE* MEMORY LOCATION (SEE PROG B)
 - OR (THIS PROCEDURE) ADD THEM IN A CHOSEN FREE LOCATION.

PROCEDURE

A Set dip 2 to ON: the viewers indicate a flashing |1st free location| + |S|;

B select another free location where to add the transmitter with the UP and DOWN keys;

C press the TX Master key corresponding to the output on which the transmitter is to be added: the selected location now flashes on the viewer;

D press (within 20") the new transmitter's key: the writing on the viewer will remain fixed after a few seconds;

E re-set dip 2 to OFF.

* The first free location could be the location following the last memorised transmitter or an intermediate location previously occupied by a transmitter that has been eliminated (see MANU B)

N.B. see also pg. II of the USER'S FILE

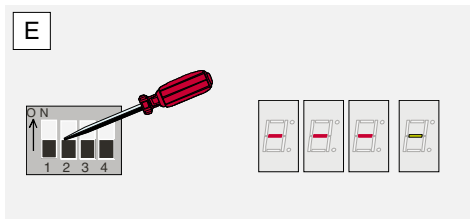
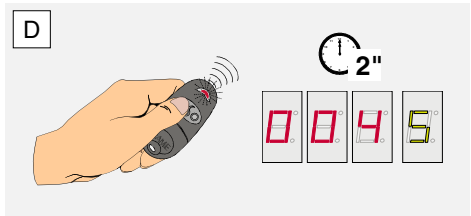
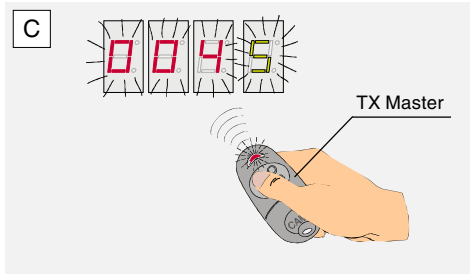
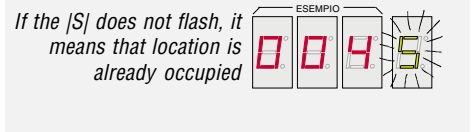
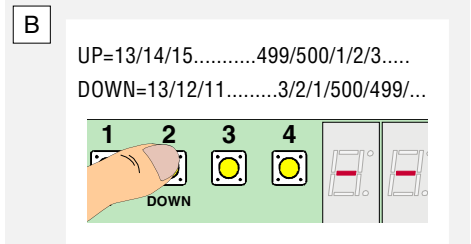
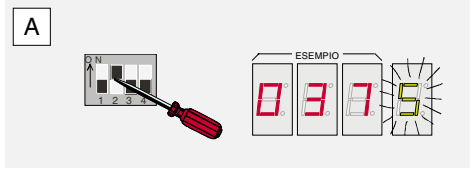

ENGLISH

MANU B - Deletes transmitters

IT IS POSSIBLE TO ELIMINATE ONE OR MORE TRANSMITTERS FROM THE SYSTEM (TO ELIMINATE THEM ALL IT IS NECESSARY TO RE-SET THE ENTIRE PROGRAMMING, SEE MANU D). LOCATIONS EMPTIED IN THIS MANNER CAN BE SUBSEQUENTLY OCCUPIED BY OTHER TRANSMITTERS (SEE MANU A)

PROCEDURE

A Press any key from the transmitter to be deleted and read the memory location occupied on viewer A;

B Set dip 1 to ON: the message `/001/` + `/C/` appear lighted up without flashing on the viewers;

C with the UP and DOWN keys select the location of the transmitter to be deleted with the UP and DOWN keys;

D press any key in the TX Master: `/C/` flashes on viewer B;

E re-set dip 1 to OFF.

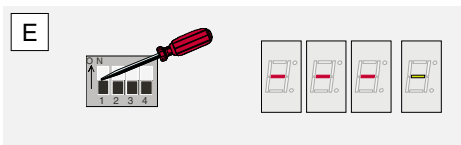
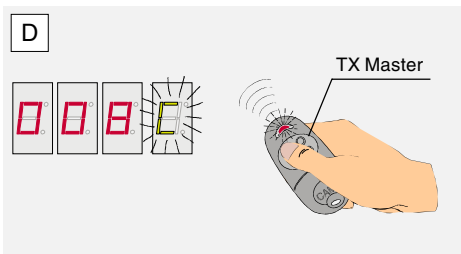
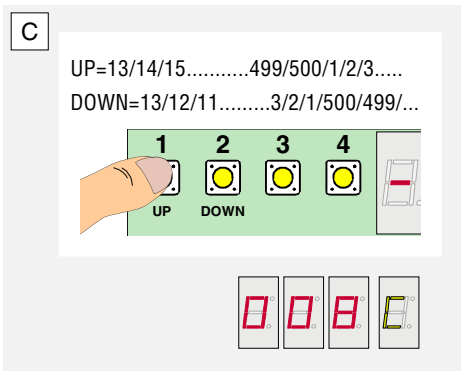
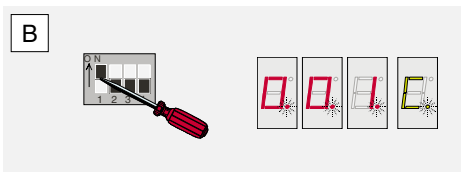
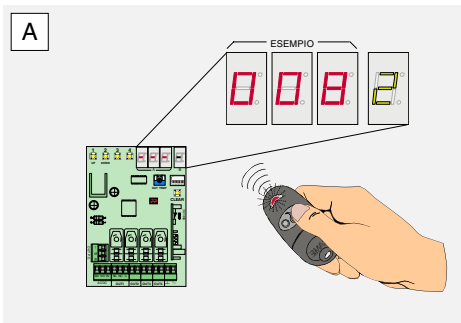

MANU C - Inhibits a transmitter's keys

IT IS ALSO POSSIBLE TO INHIBIT ONE OR MORE TRANSMITTER KEYS (BUT NOT ALL ITS KEYS) INSTEAD OF COMPLETELY ELIMINATING IT.

PROCEDURE

A Press a transmitter key to read the memory location occupied on viewer A;

B set dip 2 to ON (viewer A displays the first free memory location, viewer B displays a flashing /S/);

C select the transmitter's location with the UP and DOWN keys: the /S/ stops flashing but remains lighted;

D press the key in the TX Master corresponding to the key that must be inhibited in the transmitter: the writing flashes;

E press (within 10") the CLEAR key: the writing stops flashing and remains lighted;

F re-set dip 2 to OFF.

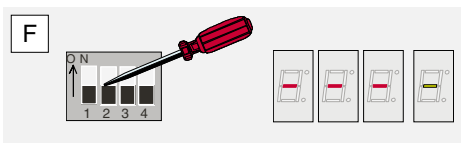
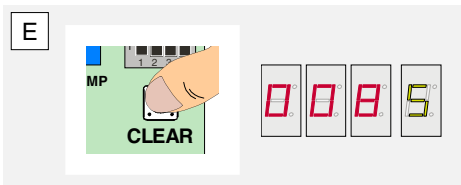
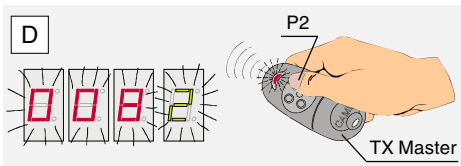
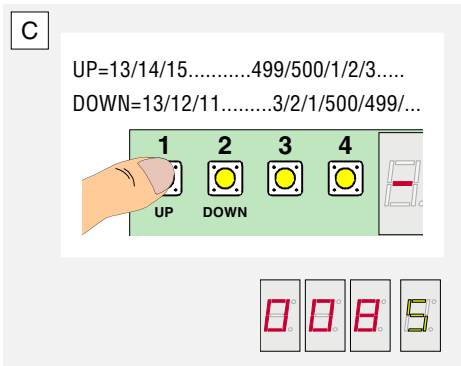
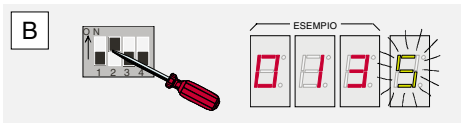
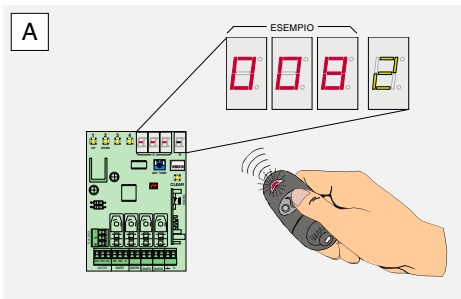

MANU D - Deletes the entire programming

Upon COMPLETION OF THIS PROCEDURE, THE MEMORY WILL BE COMPLETELY FREE AND THE BOARD INACTIVE.

TO RE-SET PROGRAMMING FROM THE MEMORY ROLL, FIRST RE-MEMORISE THE TX MASTER WITH THE PROG A PROCEDURE

*PLEASE NOTE! THE TX MASTER **MUST** BE THE SAME ONE USED FOR THE PROGRAMMING SAVED ON THE MEMORY ROLL.*

PROCEDURE

A First set dip 1 and then 2 to ON: the message *|001| + |C|* appears on the viewers;

B press the CLEAR key: the *|c|* flashes on viewer B;

C select the password using the UP and DOWN keys;

D press the CLEAR key (the entire */password| + |c|* message flashes) and then within 5", press key 3 (the writing changes to *CLr| + |A|* and then to *|001| + |C|* with the C flashing);

E re-set dips 1 and 2 to OFF.

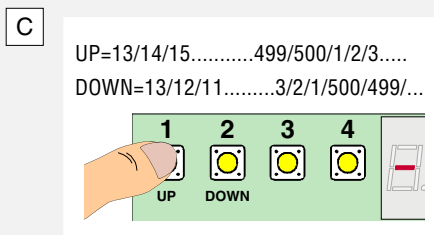
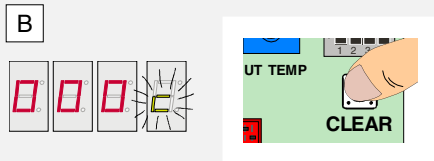

1,2,3 is the password pre-set by GAME

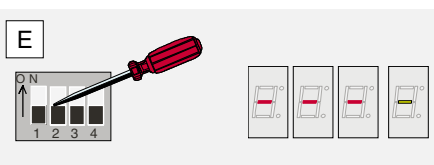
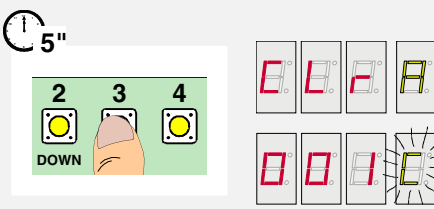
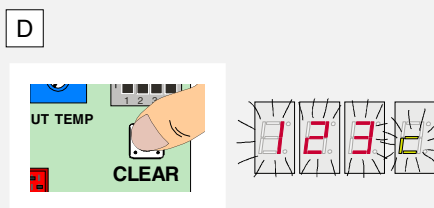

MANU E - Retrieves programming from the Memory Roll

IT IS POSSIBLE TO RETRIEVE THE PROGRAMMING PREVIOUSLY SAVED ON THE MEMORY ROLL AT ANY TIME (SEE PROG F).

PLEASE NOTE! THE TX MASTER MUST BE THE SAME ONE USED FOR THE PROGRAMMING SAVED ON THE MEMORY ROLL.

PROCEDURE

A Insert (*) the Memory Roll in its appropriate connector;

B first press and keep pressed any TX Master key and then key 1 on the receiver; Release both only when (10") /P/ appears on viewer B;

C remove (*) the Memory Roll and file it

! * **WARNING!** Prior to any board connecting or disconnecting operation, turn off the power to the system.

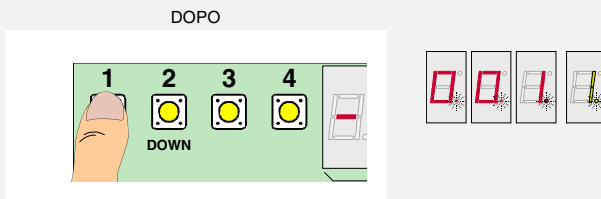
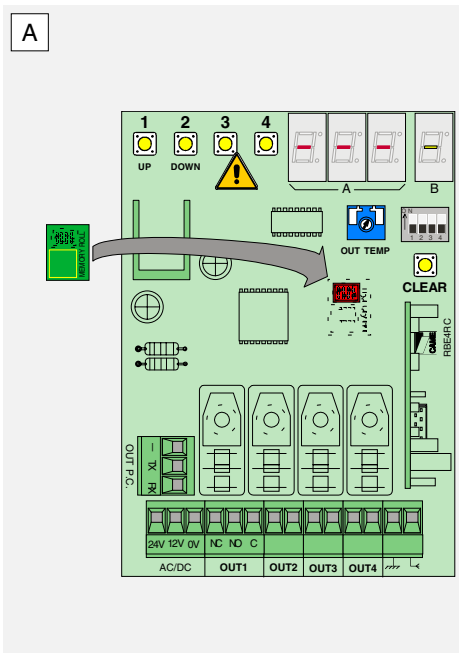

All 255 memory blocks transferred to the receiver scroll in quick succession on viewer A

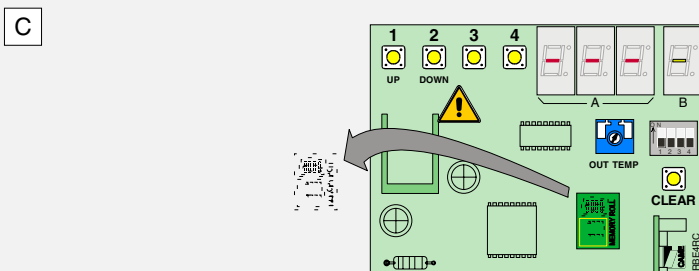



ASSISTENZA TECNICA
NUMERO VERDE
☎ 800 295830

Web
www.came.it
E-MAIL
info@came.it



CAME CANCELLI AUTOMATICI S.P.A.

Dossón di Casier (TREVISO)

☎ (+39) 0422 4940 ☎ (+39) 0422 4941

CAME LOMBARDIA S.R.L. COLOGNO M. (MI)
☎ (+39) 02 26708293 ☎ (+39) 02 25490288

CAME SUD S.R.L. NAPOLI
☎ (+39) 081 7524455 ☎ (+39) 081 7529109

CAME (AMERICA) L.L.C. MIAMI (FL)
☎ (+1) 305 5930227 ☎ (+1) 305 5939823

CAME AUTOMATISMOS S.A. MADRID
☎ (+34) 091 5285009 ☎ (+34) 091 4685442

CAME BELGIUM LESSINES
☎ (+32) 068 333014 ☎ (+32) 068 338019

CAME FRANCE S.A. NANTERRE CEDEX (PARIS)
☎ (+33) 01 46130505 ☎ (+33) 01 46130500

CAME GMBH KORNTAL BEI (STUTT GART)
☎ (+49) 07 11839590 ☎ (+49) 07 118395925

CAME GMBH SEEFELD BEI (BERLIN)
☎ (+49) 03 33988390 ☎ (+49) 03 339885508

CAME PL SP.ZO.O. WARSZAWA
☎ (+48) 022 8365076 ☎ (+48) 022 8369920

CAME UNITED KINGDOM LTD NOTTINGHAM
☎ (+44) 01159 387200 ☎ (+44) 01159 382694