

Action

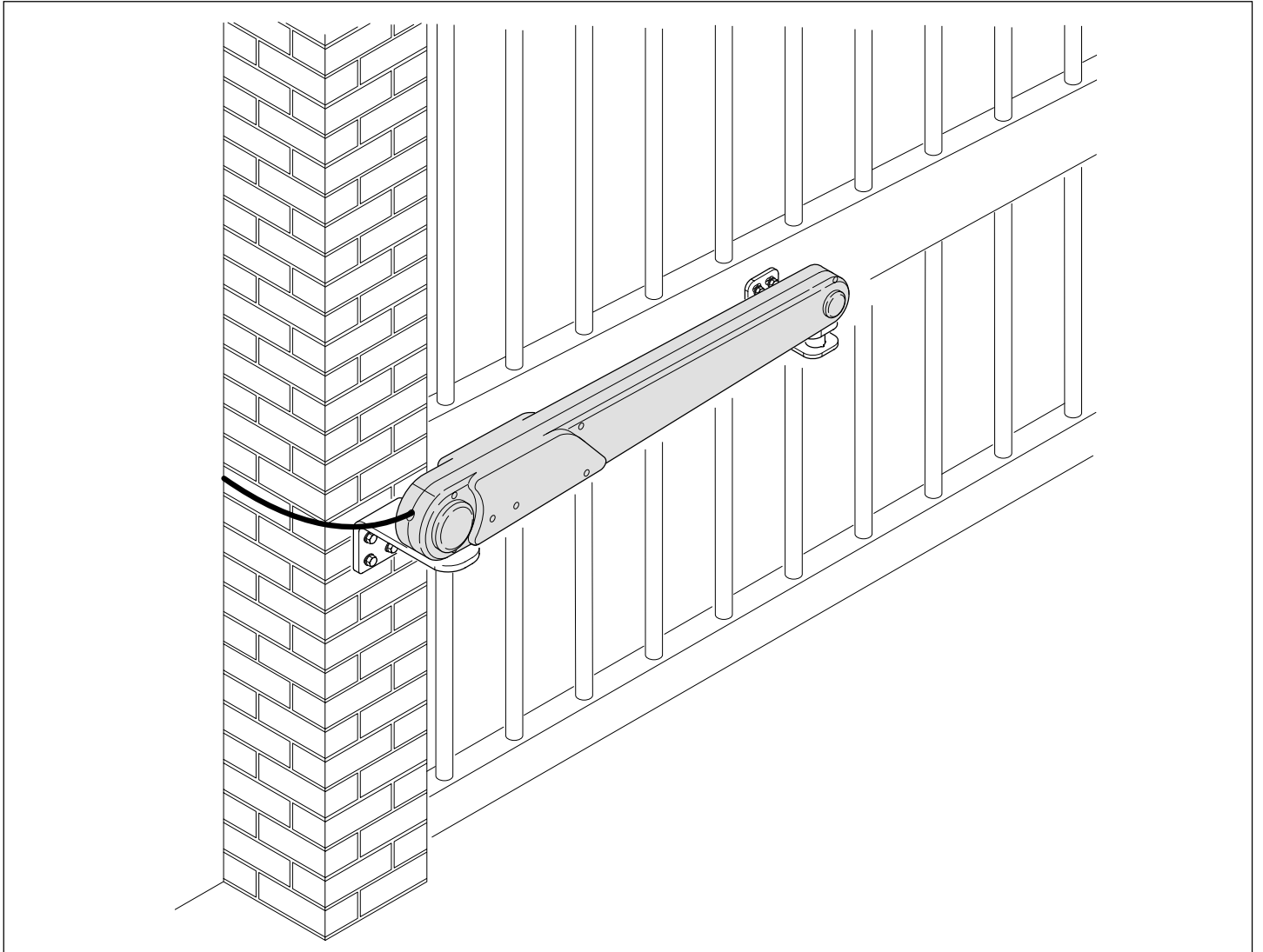

GENIUS®

COMPANY
WITH QUALITY SYSTEM
CERTIFIED BY DNV
=ISO 9001/2000=

CE

AVVERTENZE PER L'INSTALLATORE

OBBLIGHI GENERALI PER LA SICUREZZA

- ATTENZIONE! È importante per la sicurezza delle persone seguire attentamente tutta l'istruzione. Una errata installazione o un errato uso del prodotto può portare a gravi danni alle persone.**
 - Leggere attentamente le istruzioni prima di iniziare l'installazione del prodotto.
 - I materiali dell'imballaggio (plastica, polistirolo, ecc.) non devono essere lasciati alla portata dei bambini in quanto potenziali fonti di pericolo.
 - Conservare le istruzioni per riferimenti futuri.
 - Questo prodotto è stato progettato e costruito esclusivamente per l'utilizzo indicato in questa documentazione. Qualsiasi altro utilizzo non espressamente indicato potrebbe pregiudicare l'integrità del prodotto e/o rappresentare fonte di pericolo.
 - GENIUS declina qualsiasi responsabilità derivata dall'uso improprio o diverso da quello per cui l'automatismo è destinato.
 - Non installare l'apparecchio in atmosfera esplosiva: la presenza di gas o fumi infiammabili costituisce un grave pericolo per la sicurezza.
 - Gli elementi costruttivi meccanici devono essere in accordo con quanto stabilito dalle Norme EN 12604 e EN 12605.
Per i Paesi extra-CEE, oltre ai riferimenti normativi nazionali, per ottenere un livello di sicurezza adeguato, devono essere seguite le Norme sopra riportate.
 - GENIUS non è responsabile dell'inosservanza della Buona Tecnica nella costruzione delle chiusure da motorizzare, nonché delle deformazioni che dovessero intervenire nell'utilizzo.
 - L'installazione deve essere effettuata nell'osservanza delle Norme EN 12453 e EN 12445. Il livello di sicurezza dell'automazione deve essere C+D.
 - Prima di effettuare qualsiasi intervento sull'impianto, togliere l'alimentazione elettrica e scollegare le batterie.
 - Prevedere sulla rete di alimentazione dell'automazione un interruttore onnipolare con distanza d'apertura dei contatti uguale o superiore a 3 mm. È consigliabile l'uso di un magnetotermico da 6A con interruzione onnipolare.
 - Verificare che a monte dell'impianto vi sia un interruttore differenziale con soglia da 0,03 A.
 - Verificare che l'impianto di terra sia realizzato a regola d'arte e collegarvi le parti metalliche della chiusura.
 - L'automazione dispone di una sicurezza intrinseca antischiacciamento costituita da un controllo di coppia. E' comunque necessario verificarne la soglia di intervento secondo quanto previsto dalle Norme indicate al punto 10.
 - I dispositivi di sicurezza (norma EN 12978) permettono di proteggere eventuali aree di pericolo da **Rischi meccanici di movimento**, come ad Es. schiacciamento, coinvolgimento, cesoimento.
 - Per ogni impianto è consigliato l'utilizzo di almeno una segnalazione luminosa nonché di un cartello di segnalazione fissato adeguatamente sulla struttura dell'infixo, oltre ai dispositivi citati al punto "16".
 - GENIUS declina ogni responsabilità ai fini della sicurezza e del buon funzionamento dell'automazione, in caso vengano utilizzati componenti dell'impianto non di produzione GENIUS.
 - Per la manutenzione utilizzare esclusivamente parti originali GENIUS.
 - Non eseguire alcuna modifica sui componenti facenti parte del sistema d'automazione.
 - L'installatore deve fornire tutte le informazioni relative al funzionamento manuale del sistema in caso di emergenza e consegnare all'Utente utilizzatore dell'impianto il libretto d'avvertenze allegato al prodotto.
 - Non permettere ai bambini o persone di sostare nelle vicinanze del prodotto durante il funzionamento.
 - Tenere fuori dalla portata dei bambini radiocomandi o qualsiasi altro datore di impulso, per evitare che l'automazione possa essere azionata involontariamente.
 - Il transito tra le ante deve avvenire solo a cancello completamente aperto.
 - L'Utente utilizzatore deve astenersi da qualsiasi tentativo di riparazione o d'intervento diretto e rivolgersi solo a personale qualificato.
 - Non mettere in corto circuito i poli delle batterie e non tentare di ricaricarle con alimentatori diversi dalle schede Master o Slave.
 - Non gettare le batterie esauste nei rifiuti ma smaltirle utilizzando gli appositi contenitori per consentirne il riciclaggio. I costi di smaltimento sono già stati pagati dalla casa costruttrice.
- 28) Tutto quello che non è previsto espressamente in queste istruzioni non è permesso**

IMPORTANT NOTICE FOR THE INSTALLER

GENERAL SAFETY REGULATIONS

- ATTENTION! To ensure the safety of people, it is important that you read all the following instructions. Incorrect installation or incorrect use of the product could cause serious harm to people.**
- Carefully read the instructions before beginning to install the product.
- Do not leave packing materials (plastic, polystyrene, etc.) within reach of children as such materials are potential sources of danger.
- Store these instructions for future reference.
- This product was designed and built strictly for the use indicated in this documentation. Any other use, not expressly indicated here, could compromise the good condition/operation of the product and/or be a source of danger.
- GENIUS declines all liability caused by improper use or use other than that for which the automated system was intended.
- Do not install the equipment in an explosive atmosphere: the presence of inflammable gas or fumes is a serious danger to safety.
- The mechanical parts must conform to the provisions of Standards EN 12604 and EN 12605. For non-EU countries, to obtain an adequate level of safety, the Standards mentioned above must be observed, in addition to national legal regulations.
- GENIUS is not responsible for failure to observe Good Technique in the construction of the closing elements to be motorised, or for any deformation that may occur during use.
- The installation must conform to Standards EN 12453 and EN 12445. The safety level of the automated system must be C+D.
- Before attempting any job on the system, cut out electrical power and disconnect the batteries.
- The mains power supply of the automated system must be fitted with an all-pole switch with contact opening distance of 3mm or greater. Use of a 6A thermal breaker with all-pole circuit break is recommended.
- Make sure that a differential switch with threshold of 0.03 A is fitted upstream of the system.
- Make sure that the earthing system is perfectly constructed, and connect metal parts of the means of the closure to it.

- The automated system is supplied with an intrinsic anti-crushing safety device consisting of a torque control. Nevertheless, its tripping threshold must be checked as specified in the Standards indicated at point 10.
 - The safety devices (EN 12978 standard) protect any danger areas against **mechanical movement Risks**, such as crushing, dragging, and shearing.
 - Use of at least one indicator-light is recommended for every system, as well as a warning sign adequately secured to the frame structure, in addition to the devices mentioned at point "16".
 - GENIUS declines all liability as concerns safety and efficient operation of the automated system, if system components not produced by GENIUS are used.
 - For maintenance, strictly use original parts by GENIUS.
 - Do not in any way modify the components of the automated system.
 - The installer shall supply all information concerning manual operation of the system in case of an emergency, and shall hand over to the user the warnings handbook supplied with the product.
 - Do not allow children or adults to stay near the product while it is operating.
 - Keep remote controls or other pulse generators away from children, to prevent the automated system from being activated involuntarily.
 - Transit through the leaves is allowed only when the gate is fully open.
 - The user must not attempt any kind of repair or direct action whatever and contact qualified personnel only.
 - Do not short-circuit the poles of the batteries and do not try to recharge the batteries with power supply units other than Master or Slave cards.
 - Do not throw exhausted batteries into containers for other waste but dispose of them in the appropriate containers to enable them to be recycled. Disposal costs have already been paid for by the manufacturer.
- 28) Anything not expressly specified in these instructions is not permitted.**

CONSIGNES POUR L'INSTALLATEUR

RÈGLES DE SÉCURITÉ

- ATTENTION! Il est important, pour la sécurité des personnes, de suivre à la lettre toutes les instructions. Une installation erronée ou un usage erroné du produit peut entraîner de graves conséquences pour les personnes.**
 - Lire attentivement les instructions avant d'installer le produit.
 - Les matériaux d'emballage (matière plastique, polystyrène, etc.) ne doivent pas être laissés à la portée des enfants car ils constituent des sources potentielles de danger.
 - Conserver les instructions pour les références futures.
 - Ce produit a été conçu et construit exclusivement pour l'usage indiqué dans cette documentation. Toute autre utilisation non expressément indiquée pourrait compromettre l'intégrité du produit et/ou représenter une source de danger.
 - GENIUS décline toute responsabilité qui dériverait d'usage impropre ou différent de celui auquel l'automatisme est destiné.
 - Ne pas installer l'appareil dans une atmosphère explosive: la présence de gaz ou de fumées inflammables constitue un grave danger pour la sécurité.
 - Les composants mécaniques doivent répondre aux prescriptions des Normes EN 12604 et EN 12605.
Pour les Pays extra-CEE, l'obtention d'un niveau de sécurité approprié exige non seulement le respect des normes nationales, mais également le respect des Normes susmentionnées.
 - GENIUS n'est pas responsable du non-respect de la Bonne Technique dans la construction des fermetures à motoriser, ni des déformations qui pourraient intervenir lors de l'utilisation.
 - L'installation doit être effectuée conformément aux Normes EN 12453 et EN 12445. Le niveau de sécurité de l'automatisme doit être C+D.
 - Couper l'alimentation électrique et déconnecter la batterie avant toute intervention sur l'installation.
 - Prévoir, sur le secteur d'alimentation de l'automatisme, un interrupteur onnipolaire avec une distance d'ouverture des contacts égale ou supérieure à 3 mm. On recommande d'utiliser un magnétothermique de 6A avec interruption onnipolaire.
 - Vérifier qu'il y ait, en amont de l'installation, un interrupteur différentiel avec un seuil de 0,03 A.
 - Vérifier que la mise à terre est réalisée selon les règles de l'art et y connecter les pièces métalliques de la fermeture.
 - L'automatisme dispose d'une sécurité intrinsèque anti-écrasement, formée d'un contrôle du couple. Il est toutefois nécessaire d'en vérifier le seuil d'intervention suivant les prescriptions des Normes indiquées au point 10.
 - Les dispositifs de sécurité (norme EN 12978) permettent de protéger des zones éventuellement dangereuses contre les **Risques mécaniques du mouvement**, comme l'écrasement, l'acheminement, le cisaillement.
 - On recommande que toute installation soit dotée au moins d'une signalisation lumineuse, d'un panneau de signalisation fixé, de manière appropriée, sur la structure de la fermeture, ainsi que des dispositifs cités au point "16".
 - GENIUS décline toute responsabilité quant à la sécurité et au bon fonctionnement de l'automatisme si les composants utilisés dans l'installation n'appartiennent pas à la production GENIUS.
 - Utiliser exclusivement, pour l'entretien, des pièces GENIUS originales.
 - Ne jamais modifier les composants faisant partie du système d'automatisme.
 - L'installateur doit fournir toutes les informations relatives au fonctionnement manuel du système en cas d'urgence et remettre à l'Usager qui utilise l'installation les "Instructions pour l'Usager" fournies avec le produit.
 - Interdire aux enfants ou aux tiers de stationner près du produit durant le fonctionnement.
 - Éloigner de la portée des enfants les radiocommandes ou tout autre générateur d'impulsions, pour éviter tout actionnement involontaire de l'automatisme.
 - Le transit entre les vantaux ne doit avoir lieu que lorsque le portail est complètement ouvert.
 - L'Usager qui utilise l'installation doit éviter toute tentative de réparation ou d'intervention directe et s'adresser uniquement à un personnel qualifié.
 - Ne pas mettre en court-circuit les pôles des batteries et ne pas tenter de les recharger avec d'autres platines d'alimentation que les platines Maître ou Esclave.
 - Ne pas jeter les batteries épuisées à la poubelle, mais les éliminer dans les conteneurs spécifiques pour le recyclage. Les coûts d'élimination des déchets ont déjà été payés par le constructeur.
- 28) Tout ce qui n'est pas prévu expressément dans ces instructions est interdit.**

ACTION Automated system

These instructions apply to the following model:

ACTION

The ACTION automated system automates residential swing-leaf gates with leaves of up to 1.8 m in length.

It consists of non-reversing electro-mechanical linear operators, powered by a 12 Vdc battery, each coupled to a control board recharging the battery. The SLAVE equipment (required on 2-leaf gates only) is controlled by the MASTER equipment to which all accessories and pulse generators are connected. The MASTER card can be programmed and is used to set the following: function logics, work times (by self-learning) and pause times, leaf speed, and the sensitivity of the anti-crushing device.

The non-reversing system guarantees the gate will automatically lock when the motor is not operating. A release system enables the gate to be moved by hand in case of trouble.

The ACTION automated system was designed and built for controlling vehicle access. Do not use for any other purpose.

TAB. 1 TECHNICAL SPECIFICATIONS OF ACTION OPERATOR

MODEL	ACTION
Power supply	12Vdc
Rated absorbed power (W)	48
Max static force (N)	1700
Load-free linear speed (cm./sec.)	3,2
Rod effective stroke	280 mm
Use frequency (cycles/hour)	5
Consecutive cycles on charged battery	max. 15
Battery recharge time	10' for each completed cycle
Operating ambient temperature	-20 ÷ +55 °C
Operator Weight (kg)	2,2
Protection class	IP 44
Leaf maximum length (m)	1.80
Leaf max weight (kg)	250
Operator overall dimensions LxHxD (mm)	see fig. 2
Length of operator power cable	0,7 m

1. DESCRIPTION AND TECHNICAL SPECIFICATIONS

2. DIMENSIONS

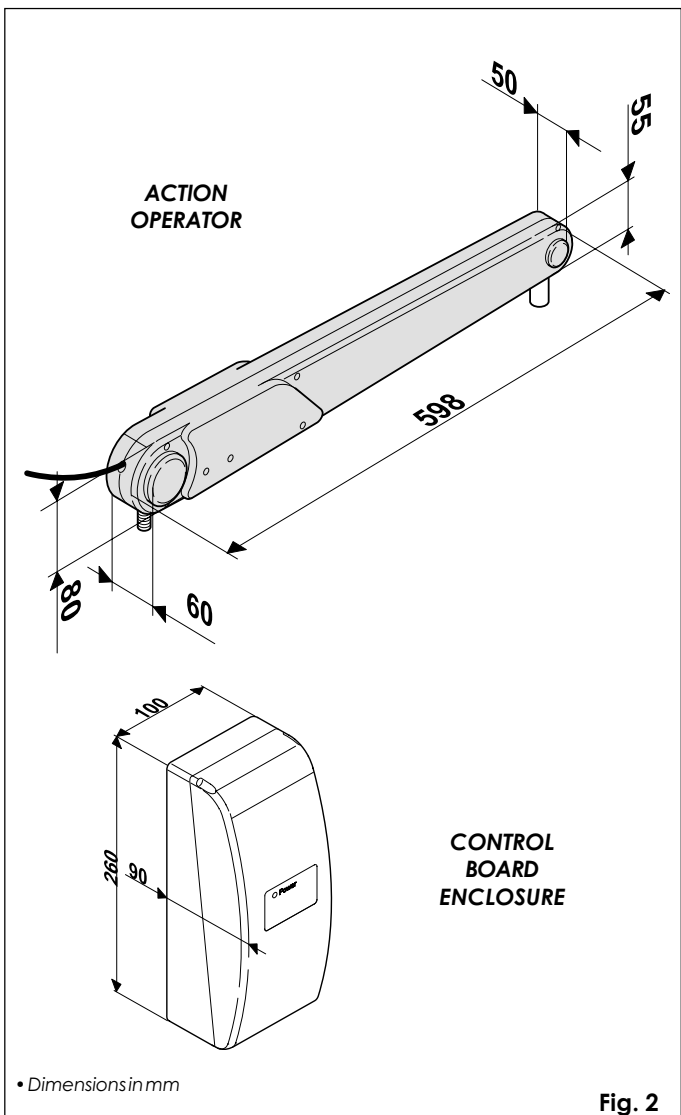
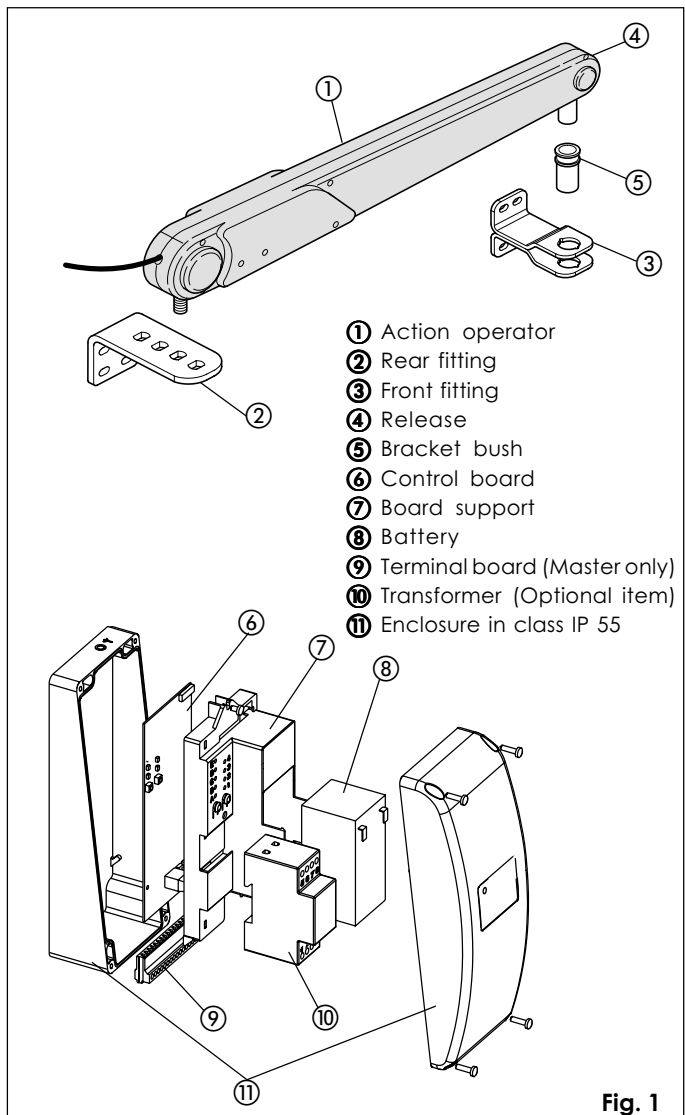

3. ELECTRONIC EQUIPMENT (standard system)

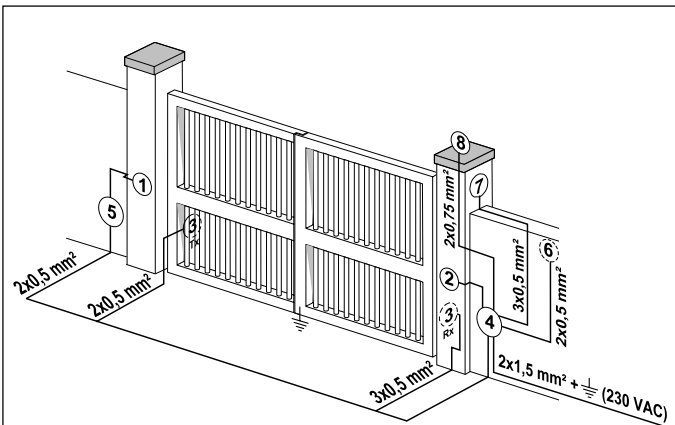

- ① Action operator
- ② Action operator
- ③ Photocells
- ④ MASTER control board (controls all accessories)
- ⑤ SLAVE control board (for 2nd leaf only)
- ⑥ Key operated push-button
- ⑦ Receiver
- ⑧ 12 Vdc flashing lamp

Notes: 1) Do not extend the operator connecting cables

- 2) To lay electric cables, use adequate rigid and/or flexible tubes.
- 3) Always separate low voltage connection cables from those operating at 230 Vac. To prevent any interference whatever, use separate sheaths.

Fig. 3

to those indicated in the technical specifications.

- Make sure that the leaves move uniformly and correctly, without any irregular friction during their entire travel.
- Make sure that the hinges are in good condition.
- Check if the mechanical stops of the limit-switches are fitted.

We advise you to have any metalwork carried out before the automated system is installed.

4.2. INSTALLATION DIMENSIONS

There are 4 possible installation dimensions Z as shown in figure 5. There is no need to cut the rear bracket to obtain dimension A. Establish the installation position of the operator by referring to Fig. 6 and to table 2.

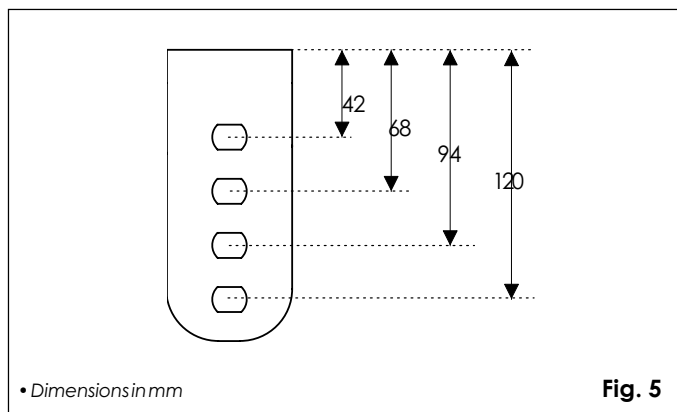

• Dimensions in mm

Fig. 5

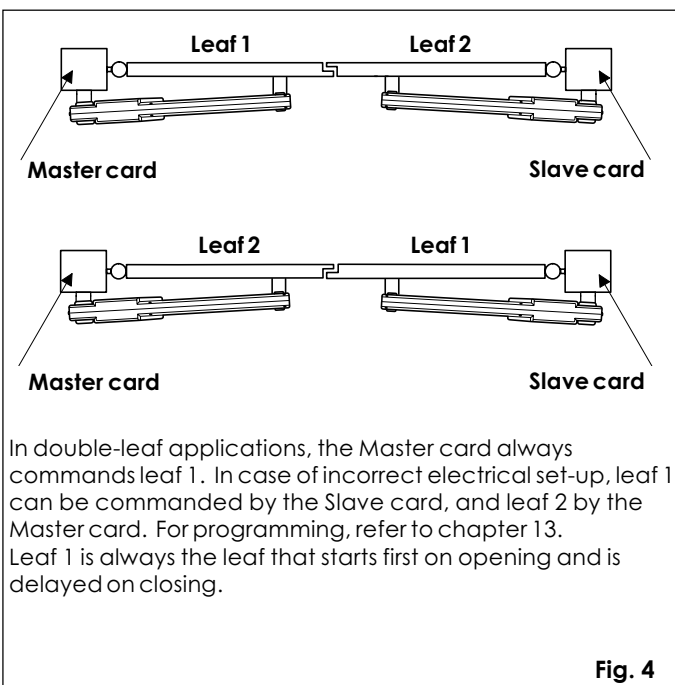

In double-leaf applications, the Master card always commands leaf 1. In case of incorrect electrical set-up, leaf 1 can be commanded by the Slave card, and leaf 2 by the Master card. For programming, refer to chapter 13. Leaf 1 is always the leaf that starts first on opening and is delayed on closing.

Fig. 4

4. INSTALLING THE AUTOMATED SYSTEM

4.1. PRELIMINARY CHECKS

To ensure safety and an efficiently operating automated system, make sure the following conditions are observed:

- The structure of the gate must be suitable for being automated. In particular, check that the structure is sufficiently strong and rigid, and that its dimensions and weight conform

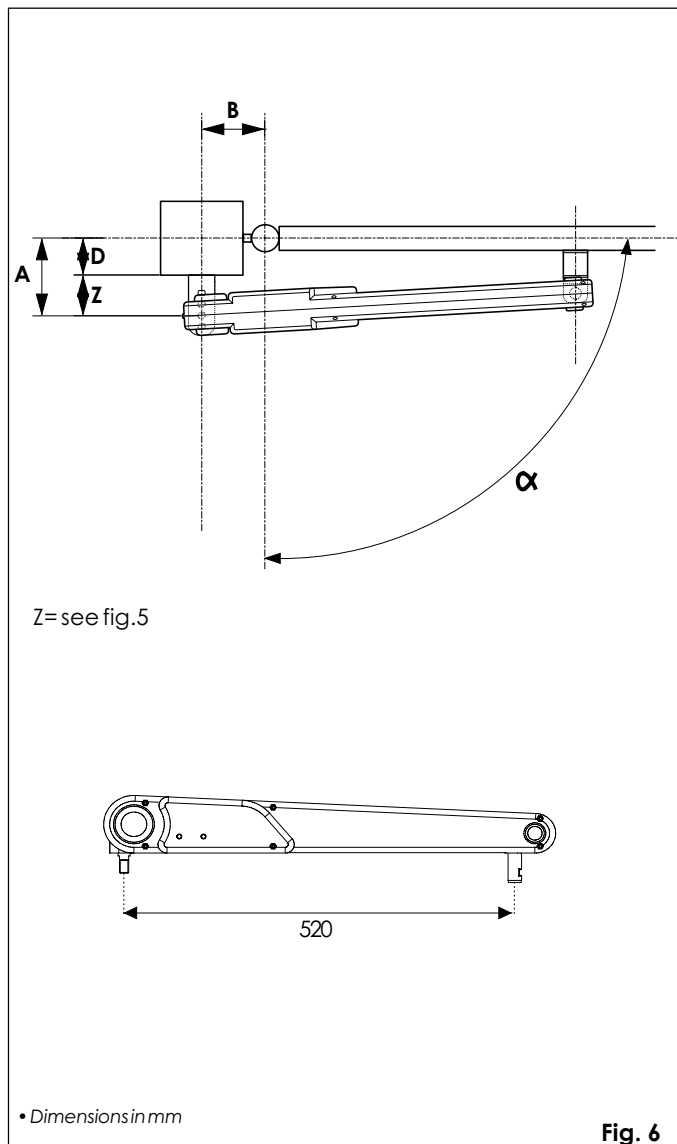







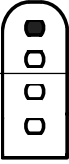
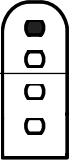
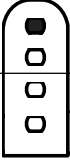
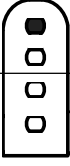
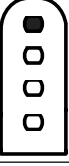

Z = see fig.5

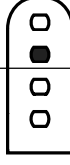
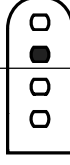
• Dimensions in mm

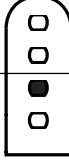
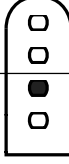
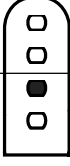
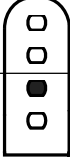
Fig. 6

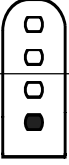
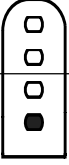
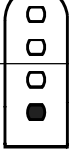
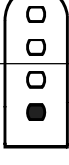
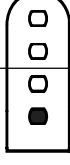
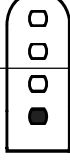
Tab.2

B							
	88 ÷ 91	92 ÷ 97	98 ÷ 102	103 ÷ 107	108 ÷ 113	114 ÷ 119	120 ÷ 126
30 ÷ 39					100° 	 90°	
40 ÷ 49			100° 	 90°			
50 ÷ 59		90°					
60 ÷ 69				100° 	 90°		
70 ÷ 79		100° 	 90°				
80 ÷ 89		90°			100° 	 90°	
90 ÷ 99			100° 	 90°			
100 ÷ 109			90°			100° 	 90°
110 ÷ 119				100° 	 90°		
120 ÷ 129		100° 	 90°				
130 ÷ 140		90°					

D

To select the dimensions, we advise you to measure dimension D and then, referring to table 2, determine dimension B. The hole for the rear fitting (dimension Z) to be used is the one obtained from the intersection of dimensions B and D, as shown in bold in table 2. The table shows all combinations of the B, D and Z dimensions that can be used, with the relevant opening angles. The white boxes indicate the non permissible dimensions.

4.3. INSTALLATION STEPS

- Secure the rear fitting to the pillar by welding or using suitable expansion plugs (Fig. 7) and ensuring it is perfectly horizontal.

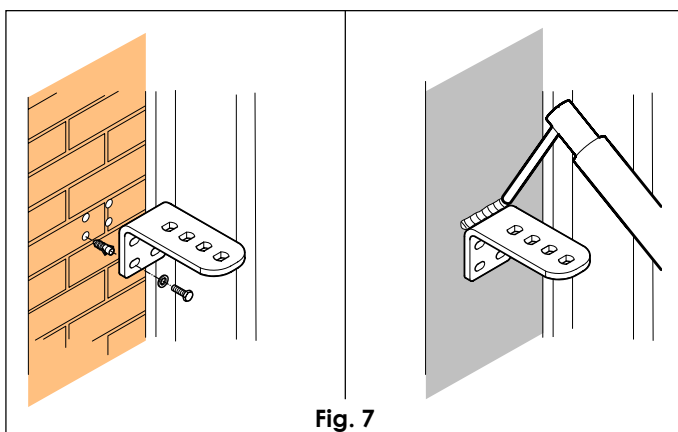

Fig. 7

- Secure the operator to the rear fitting, with the nut and washer (Fig.8), taking care to correctly fit the chamfered part of the pin in the hole of the rear fitting.

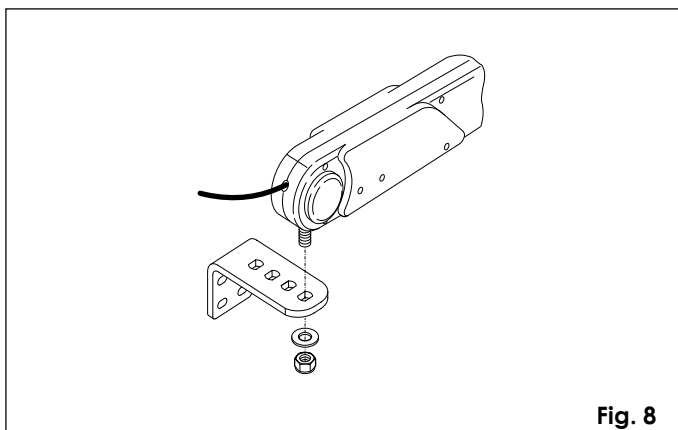

Fig. 8

- **NB.:** the operator is supplied with a travel limit pin on the closed leaf position. If necessary, use the manual release (see chpt. 16), to take the operator pin to the closed position (the pin must be on the stop position on the front of the operator) - see fig.9.
- Turn the release key anti-clockwise for 5 turns as shown in figure 9.
- Insert the bracket bush (fig.9 ref. 1) in the front fitting (fig.9). Insert the operator so that the groove of the pin coincides with the mechanical stop on the bush (fig. 10).
- Turn the release key clockwise until the pin returns to the closing stop position.
- Turn the release key anti-clockwise for 3 turns.
- Find the securing position of the front fitting on the leaf; make sure that the operator and fitting are perfectly horizontal (fig.11).

- The fitting can be either welded directly on the leaf, or screwed on, using the threaded inserts (Fig. 12).

IMPORTANT: the operator is non-reversing, so do not, on any account, try to move the leaves by hand.

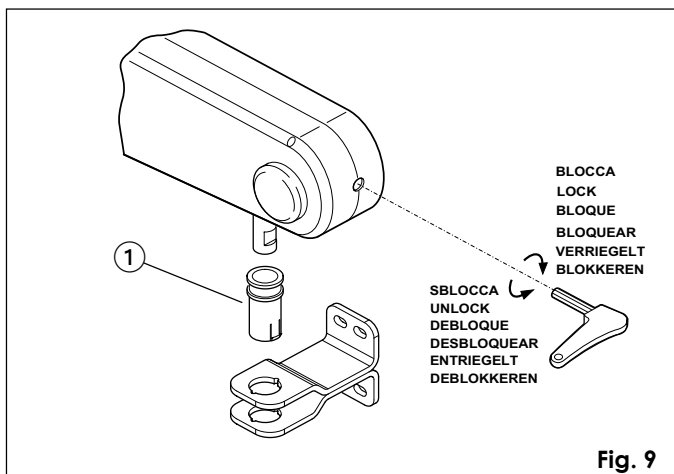

Fig. 9

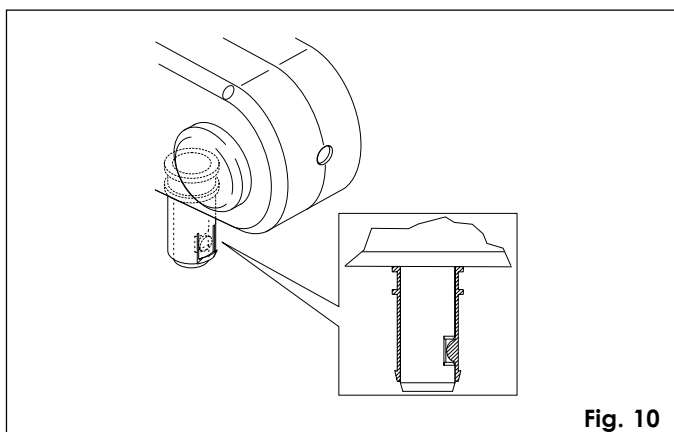

Fig. 10

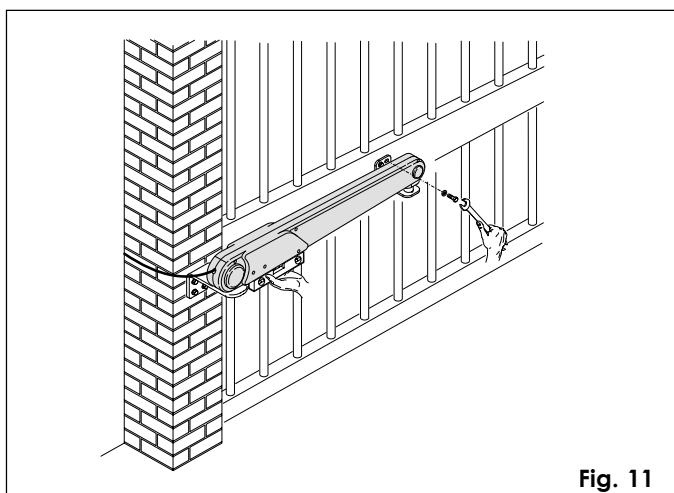

Fig. 11

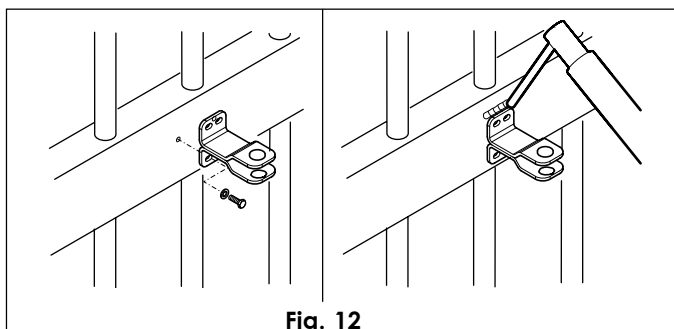

Fig. 12

MIND MASTER AND MIND SLAVE CONTROL BOARDS

5. WARNINGS

Important: Before attempting any job on the control boards (connections, maintenance), cut out electrical power and the support batteries.

- Install, upstream of the system, a differential thermal breaker with adequate tripping threshold.
- Always separate 230VAC power cable from control and safety cables (push-buttons receiver, photocells, etc.). To avoid any electrical noise, use separate sheaths or a shielded cable (with earthed shield).

6. LAY-OUT OF MASTER CARD COMPONENTS

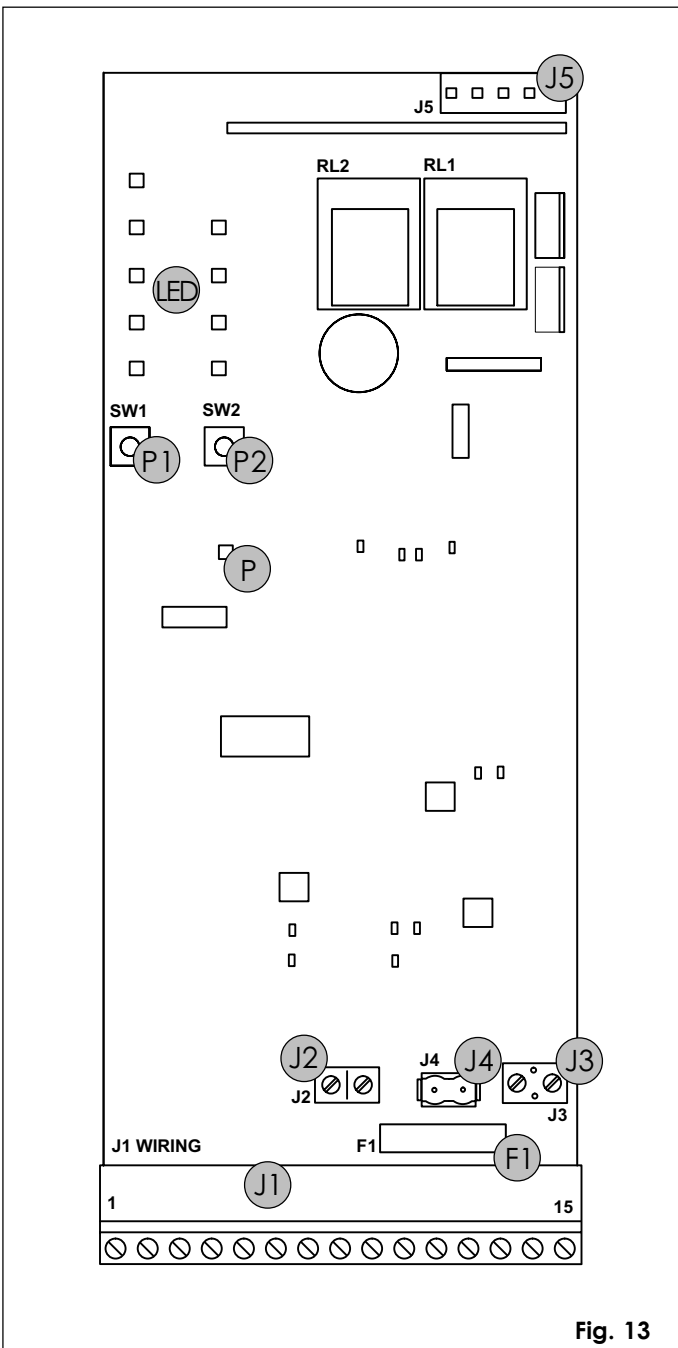

Fig. 13

7. LAY-OUT OF SLAVE CARD COMPONENTS

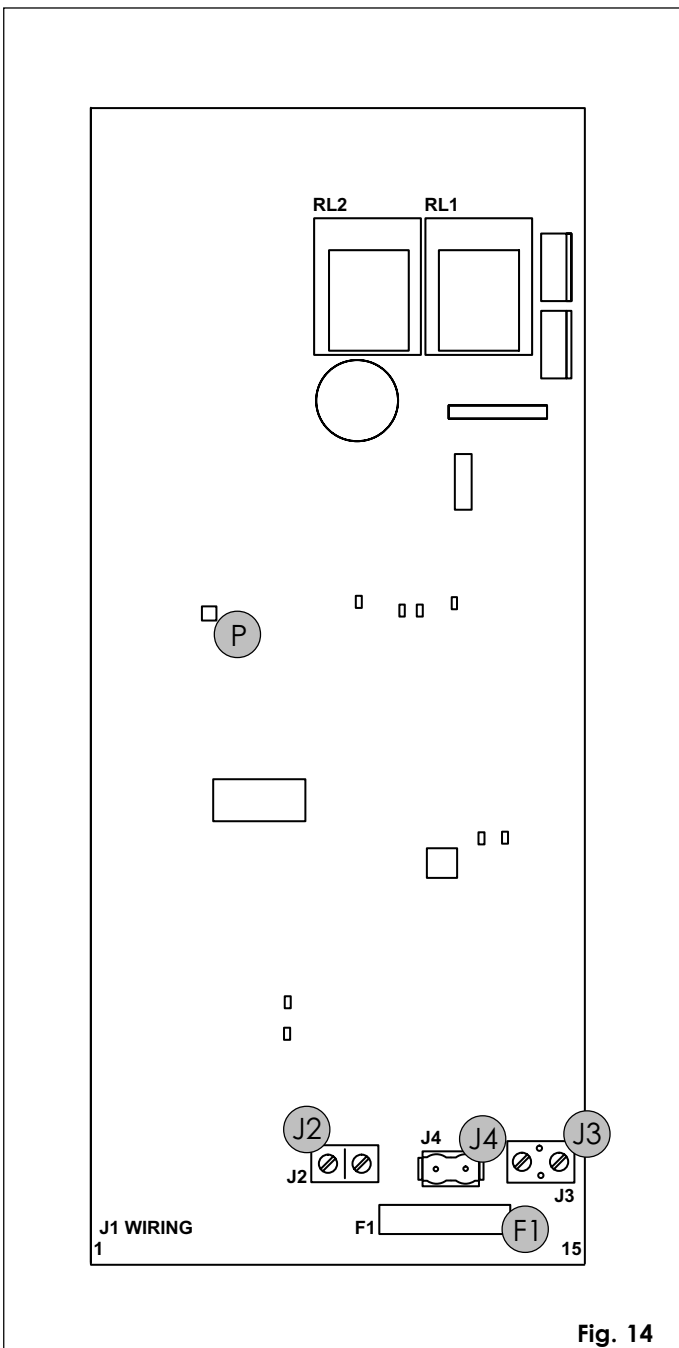

Fig. 14

LED	Programming LEDs
P	Power ON and diagnostics LED
P1	"Function" programming push-button
P2	"Value" programming push-button
F1	Battery and motor fuse - F15A
J1	Accessories Terminal board
J2	Transformer Terminal board
J3	Motor connection terminal board
J4	Battery connector
J5	Minidec connector/RP Receiver

P	Power ON and diagnostics LED
F1	Battery and motor fuse - F15A
J2	Bus connection terminal board
J3	Motor connection terminal board
J4	Battery connector

8. MASTER AND SLAVE CARDS COMMON CHARACTERISTICS

Batteries	hermetic Pb 12Vdc 1.2Ah - dimensions 96x46x50
Enclosure protection class	IP 55
Absorbed power	16 VA
Motor max current	15A
Operating ambient temperature	-20° +55°
Protection fuses	N° 1 (see fig. 13 and 14)
Anti-crushing function	Encoder - Current control

9. SLAVE CARD TECHNICAL SPECIFICATIONS

Power supply	from Master
Terminal board outputs	Motor - Battery - Bus

11. ELECTRIC CONNECTIONS

10. MASTER CARD TECHNICAL SPECIFICATIONS

Power supply	12Vac
Transformer characteristics	Primary 230 Vac - Secondary 12 Vac - 16VA
Accessories max. load at 24 Vdc	150 mA
Rapid connector max load	50 mA
Function logics	Automatic / "Stepped" Automatic / Safety device / "Stepped" semi-automatic
Opening/closing time	By self-learning
Pause time	Programmable: 5, 10, 20, 30 sec.
Leaf delay time when opening and closing	(op 0s, cl 0s) - (op 2s, cl 2s) - (op 2s, cl 4s) - (op 2s, cl 8s)
Speed	Selectable on 4 levels
Static force adjustment	Selectable on 4 levels
Terminal board inputs	Open - Open released leaf Stop - Safety devices at opng. - Safety devices at clsng.
Terminal board outputs	Flashing lamp - Motor - Bus - indicator-light - Accessories 24 Vdc - 12 Vdc power supply
Rapid connector	Minidec cards - RP cards
Programmable functions	Logic - pause time - leaf opening and closing delay - anti-crushing force - operators speed

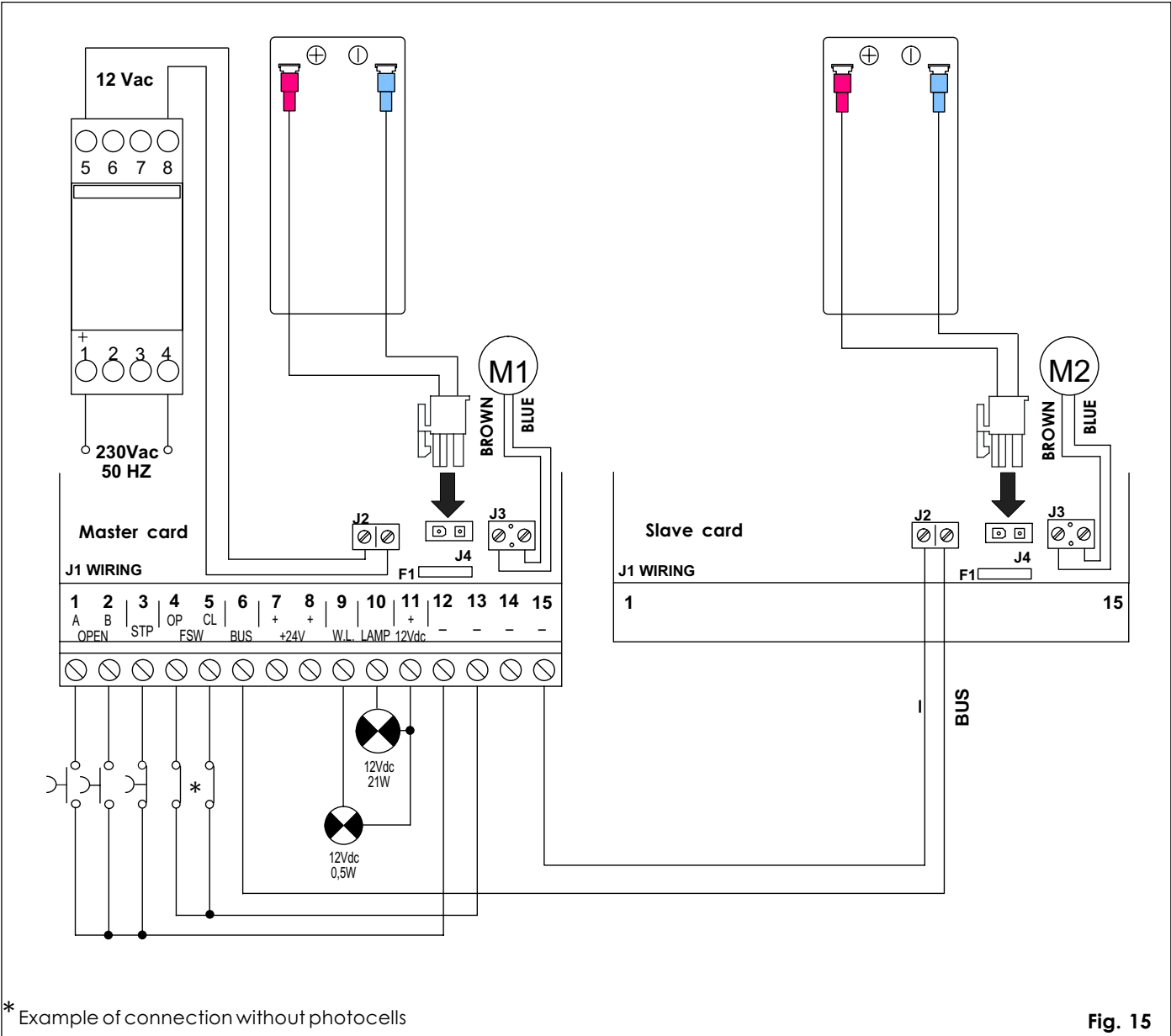

* Example of connection without photocells

Fig. 15

11.1. Connection of photocells and safety devices

Before connecting the photocells (or other devices) we advise you to select the type of operation according to the movement zone to be protected (see fig.16).

Opening safety devices: they operate only during the gate opening movement and, therefore, they are suitable for protecting the zone between the opening leaves and fixed obstacles (walls, etc) against the risk of impact and crushing.

Closing safety devices: they operate only during the gate closing movement and, therefore, are suitable for protecting the closing zone against the risk of impact.

Opening/closing safety devices: they operate during the gate opening and closing movements and, therefore, they are suitable for protecting the opening and closing zones against the risk of impact.

N.B.: If one or more devices have the same function (opening or closing), they must be connected to each other in series.
N.C. contacts must be used.

Application examples

Commonly used wiring lay-outs:

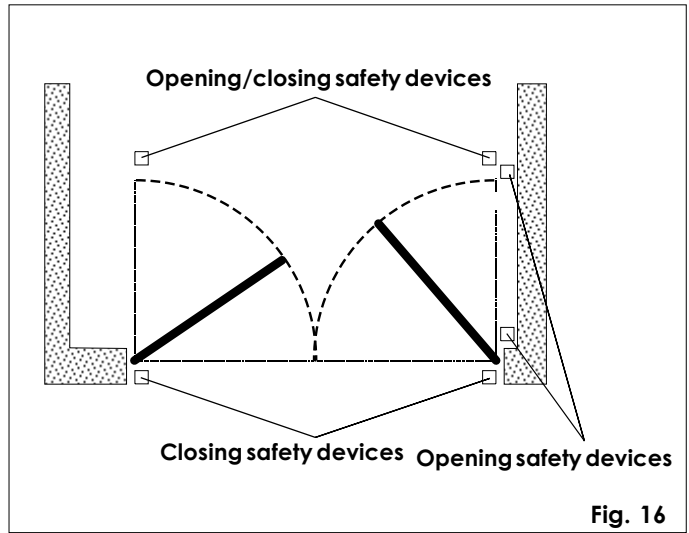

Fig. 16

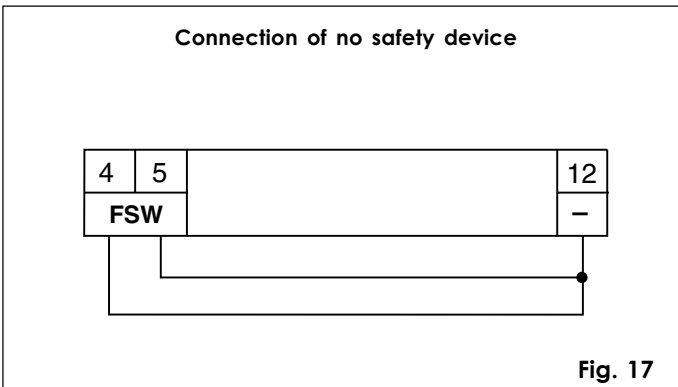

Fig. 17

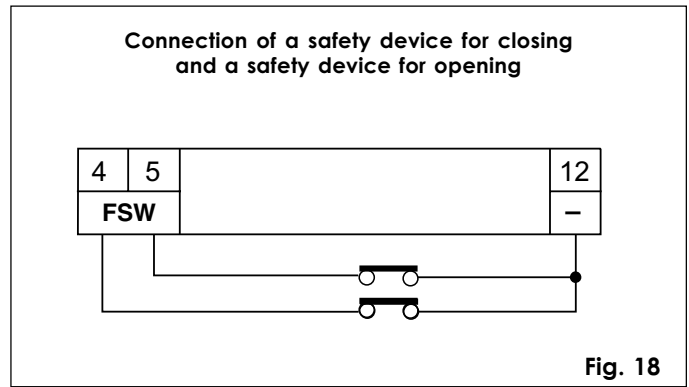

Fig. 18

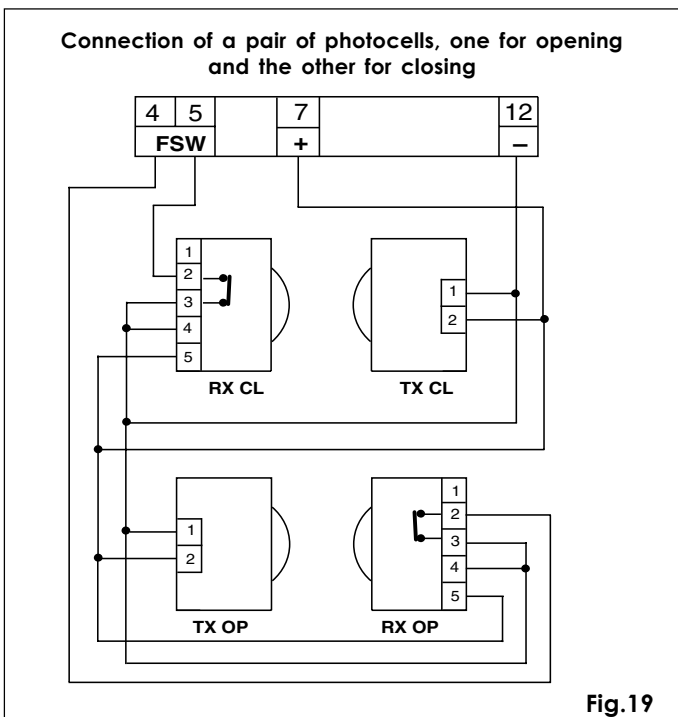

Fig.19

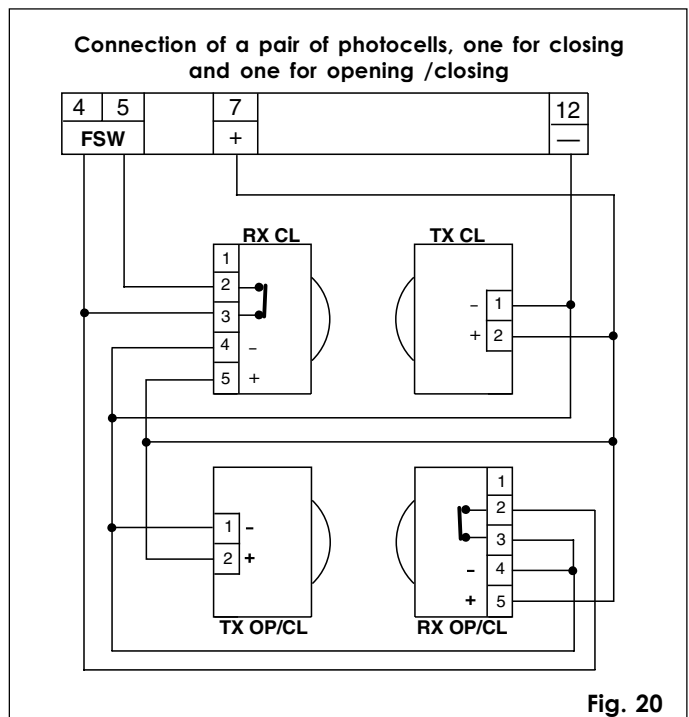
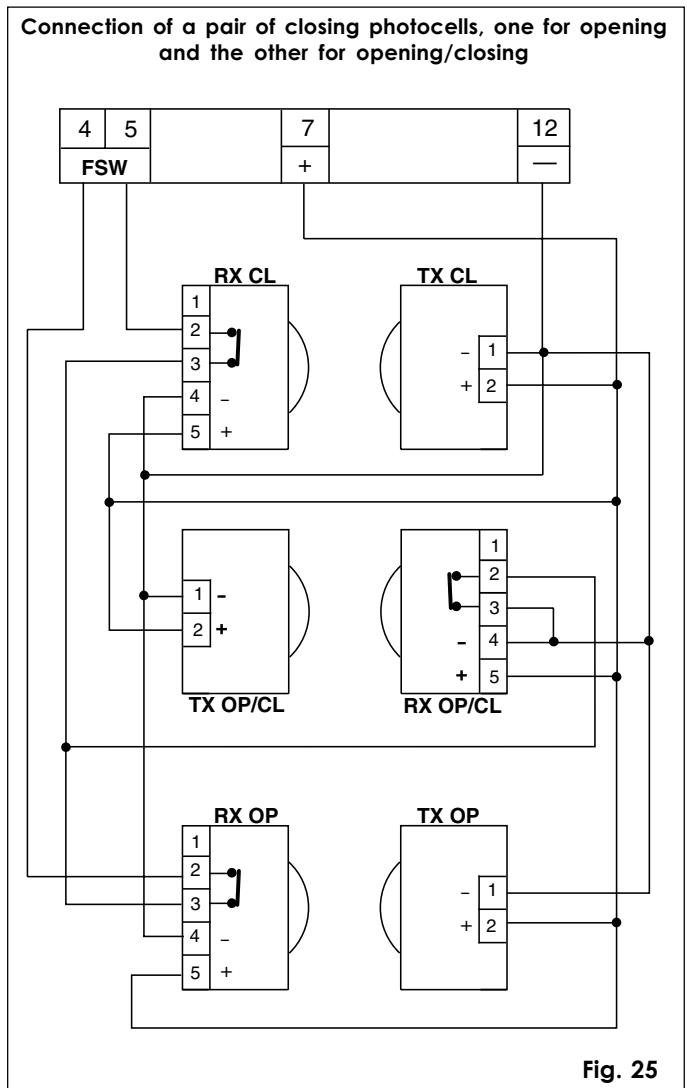
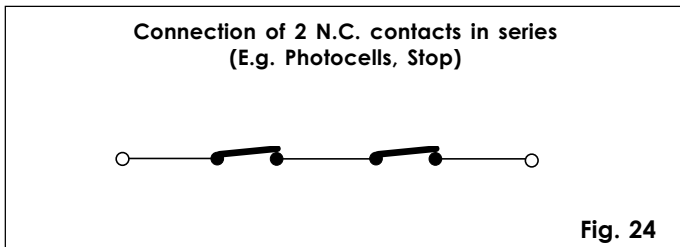
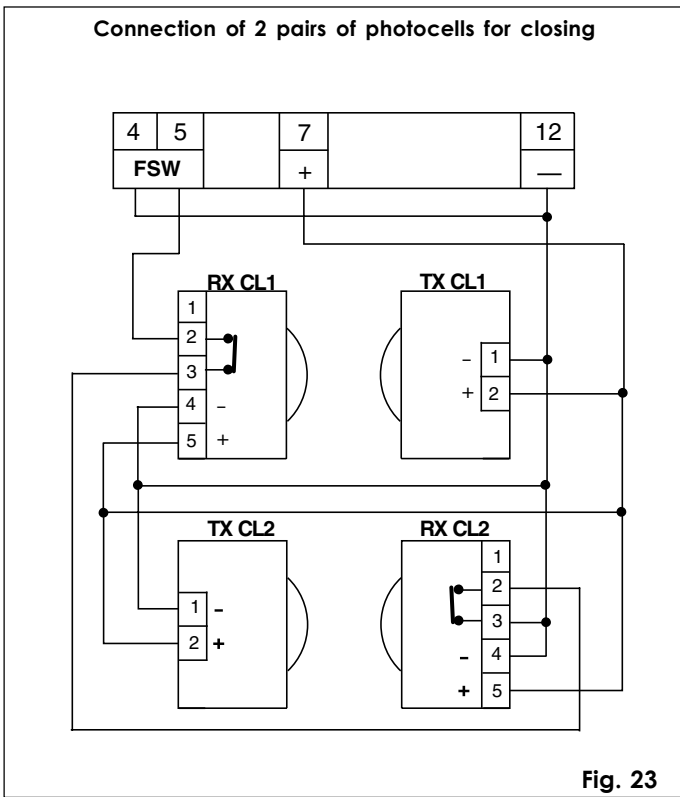
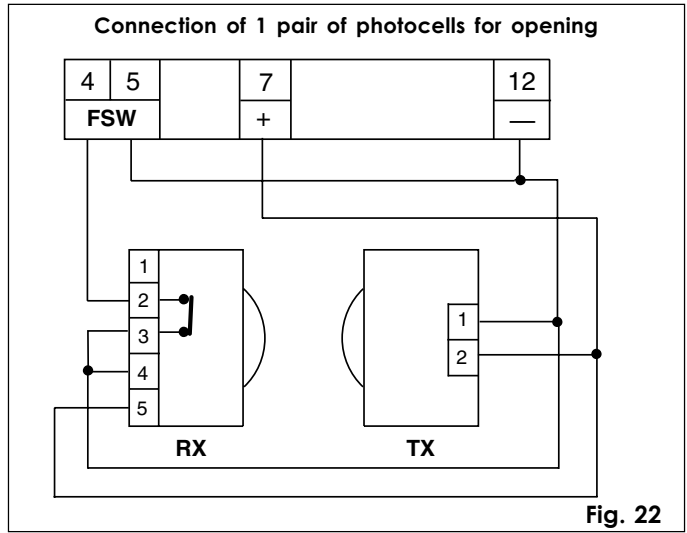
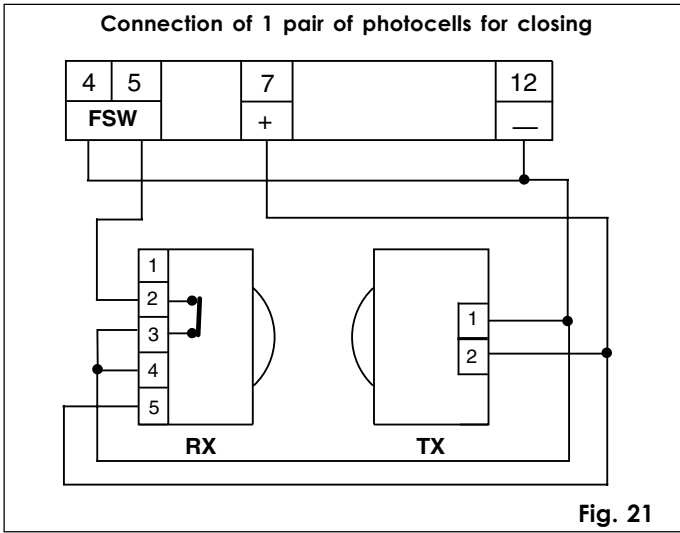

Fig. 20



11.2. J1 TERMINAL BOARD - ACCESSORIES

J1 Terminal board for Master Card - Accessories (fig. 15)
Low voltage terminal board used for connecting all accessories.

24 Vdc

- Negative for powering accessories (terminals 12, 13, 14, 15)
- + Positive for powering accessories + 24 Vdc (terminals 7 and 8)

Important: The maximum load of the accessories powered at

24 Vdc is 150 mA. When the automated system is idle, the accessories are not powered. To calculate absorption values, refer to the instructions for individual accessories.

OPEN A - "TOTAL OPENING" (terminal 1) OPEN command: any device (e.g. push-button) which, by closing a contact, provides an opening and/or closing pulse for both gate leaves.

To install several opening pulse generators, connect the N.O. contacts in parallel (see fig. 26).

OPEN B - "RELEASED LEAF OPENING" (terminal 2) OPEN command: any device (e.g. push-button) which, by closing a contact, provides an opening and/or closing pulse for the gate leaf activated by the Master Card.
To install several opening pulse generators, connect the N.O. contacts in parallel (fig. 26).

STP - STOP Command (terminal 3): any device (e.g.: push-button) which, by opening a contact, stops gate movement.
To install several stop devices, connect the N.C. contacts in series (fig.24).
NB.: If STOP devices are not connected, jumper connect the inputs **STP** and -.

FSW
All devices (photocells, sensitive edges, magnetic loops) with **N.C.** (normally closed) contact, which, if there is an obstacle in the area they protect, operate to interrupt gate leaf movement (fig. 16).

FSW OP. - Opening safety devices contact (terminal 4): during opening, the safety devices reverse motion to closing. They do not operate during closing.
If the **Opening safety devices** are tripped when the gate is closed, they prevent the leaf opening movement.
NB.: If no opening safety devices are connected, jumper connect inputs **OP** and - (fig. 17).
The purpose of the opening safety devices is to safeguard the zone behind the gate leaves (fig. 16).

FSW CL. - Closing safety devices contact (terminal 5): during closing, the safety devices reverse motion to opening. They do not operate during opening.
If the **Closing safety devices** are tripped when the gate is open, they prevent the leaf closing movement.
NB.: If no closing safety devices are connected, jumper connect inputs **CL** and - (fig. 17).
The purpose of the closing safety devices is to safeguard the leaf movement area during closing (fig. 16).

BUS - (terminal 6): Connection between the master and slave equipment. The Bus connection supplies the current for charging the slave card battery and enables communication between the two equipment (terminals 6 and 15 of the master card - connector J2 of the slave card).
To connect, use 2 wires with diameter of 0.5 mm² or greater.

W. LIGHT - (terminals 9 and 11): Power supply for the indicator-light, 12 Vdc 0.5 W max. (terminals 9 and 11). To avoid compromising correct operation of the system, **do not exceed** the indicated power. For instructions on operation of the indicator-light, consult table 3.

LAMP - (terminals 10 and 11): Flashing lamp output, 12 Vdc 21 W. BA15S lamp. To avoid compromising correct operation of the system, **do not exceed** the indicated power.

11.3. J2 Terminal board

It is used for connecting the transformer (optional item), 12 Vac 16 VA. Place the transformer in its compartment, as shown in figure 29, and make the connection as shown in figure 15. Alternatively, the transformer can be remotely located up to a distance of 100mt from the equipment, using wires with a diameter of 0.5 mm².

11.4. J3 Terminal board - Motor Connection

This terminal board is used for connecting the motor (see fig. 15). For wire colours, refer to fig. 15.

11.5. J4 Connector - Battery connection

Connect the operator support battery (fig. 15) to this connector. The battery is housed as shown in figure 29.
N.B.: The batteries are not supplied fully charged; however, the charge is sufficient for programming and setting-up the system.

11.6. J5 Connector - Quick-fit for Minidec and Rp - 12 Vdc

This is used for rapid connection of the Minidec cards and RP receivers.
IMPORTANT: do not use Decoder cards on the quick-fit connection.
In case of a mains power cut, this connector is powered for twelve hours - after this time, the opening push-buttons (terminals 1 and 2) are the only active commands.
The connector is powered down to store sufficient energy for running some emergency manoeuvres in the space of 30 days.

Tab. 3

Gate status	Indicator-light status
Closed	Light Off
Open - Open in pause status	Lighted
Closing	Flashing
Opening	Lighted
Blocked	Lighted

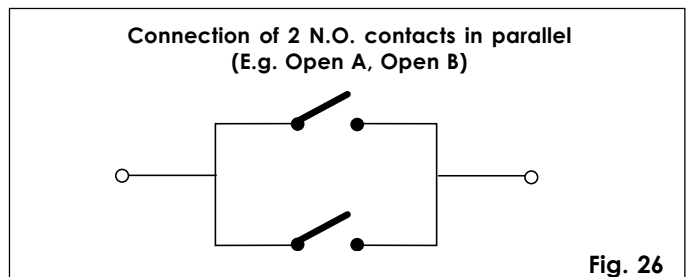

Fig. 26

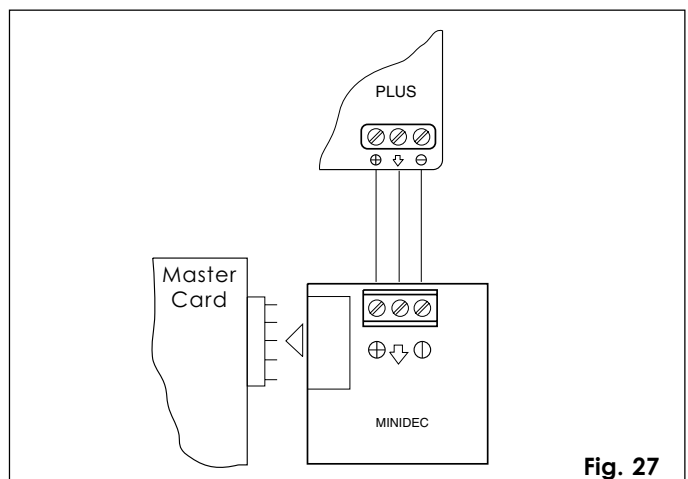

Fig. 27

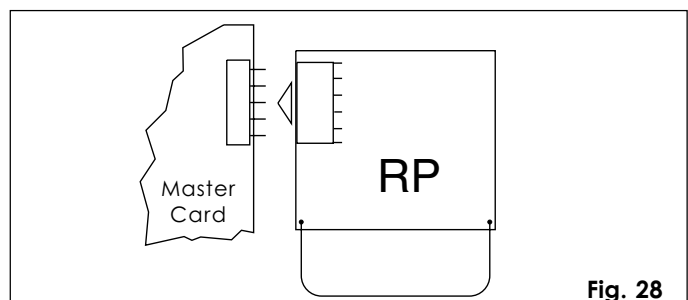

Fig. 28

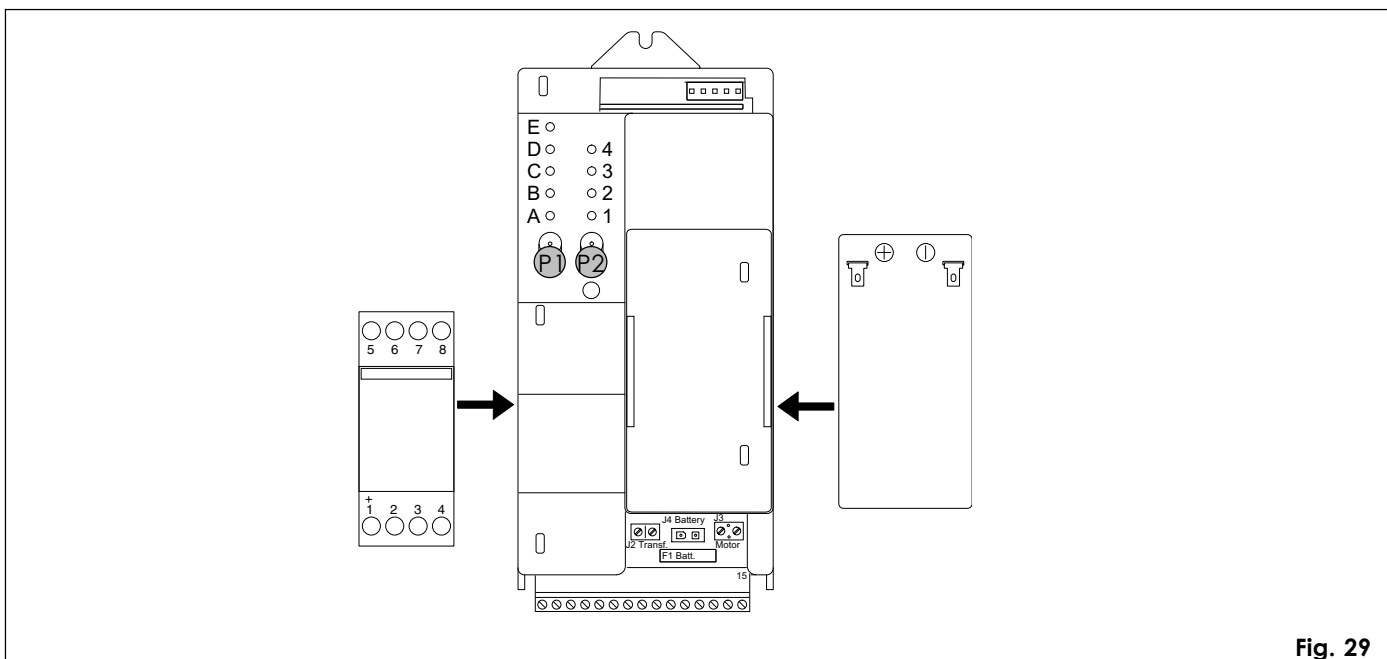

Fig. 29

12. Diagnostics

The "P" LED (see fig. 21) has a diagnostic function. There are 4 LED statuses.

- Steady light indicating mains power ON and battery charged.
- Flashing slowly (lights every second), indicates no mains power but battery charged
- Flashing quickly (lights every 250 msec.) indicates mains power ON but discharged battery
- Light OFF indicates no mains power and discharged battery.

13. Status of inputs

The equipment has a function for checking the status of the inputs on the terminal board.

This is how to access the function:

In the all LEDs OFF status (both LEDs with letters and numbers), press push-button P2 – the status of the inputs will be shown in the LED columns with letters and numbers, as shown in table 4.

Tab.4

Led	ON	OFF
A = Open A	Command active	Command inactive
B = Open B	Command active	Command inactive
C = Stop	Command inactive	Command active
D = Fsw op	Safety devices disabled	Safety devices enabled
E = Fsw cl	Safety devices disabled	Safety devices enabled

When you have finished checking, press push-button P2 again to exit the inputs status function.

N.B.: The LEDs status check function stays active for 5 minutes and then the board returns to all LEDs OFF status.

WARNING : When you access the inputs status function, all accessories are powered, even with the gate idle. Push-button P1 is active and can be used as Open A.

14. PROGRAMMING

To access the "PROGRAMMING" mode, press push-buttons P1 and P2 (fig. 29). The 5 programming functions are indicated by LEDs with letters, whereas the modifiable values are indicated by numbered LEDs.

Push-button P1 is used to select the function to be programmed.

Push-button P2 is used to modify the value of the selected function.

- If you press push-button P1, LED A lights up; use push-button P2 to select the required logic as shown in table 5.
- If you press push-button P1 again, LED B lights up; use push-button P2 to select the required pause times (for logics A, AP and S only) as shown in table 5.
- If you press push-button P1 again, LED C lights up; use push-button P2 to select the required leaf delays as shown in table 5.
- If you press push-button P1 again, LED D lights up; use push-button P2 to select the static force of the operators as shown in table 5.
- If you press push-button P1 again, LED E lights up; use push-button P2 to select the speed of the operators as shown in table 5.
- If you press push-button P1 again, the five LEDs light up steadily to indicate access to the learning function. There are two learning modes: simple and complete. The travel limit stops are essential for simple learning.

•Simple learning

By using just one command, this procedure enables self-learning of work times and decelerations. Make sure that the leaves are closed.

While the 5 function LEDs are lighted steadily, briefly press (about 1 second) the P2 push-button - the operators start the opening manoeuvre, and the function LEDs begin flashing; Wait for the operators to reach the opening stops. The learning procedure has finished.

•Complete learning

This procedure is used to define the deceleration and stop points of the operators. The procedure differs depending on whether the gate is single leaf or double leaf. Make sure that the leaves are closed.

Procedure for double-leaf gate

While the 5 function LEDs are lighted steadily, hold down push-button P2 for about 3 seconds - operator 1 (master) starts the opening manoeuvre; the following functions are commanded either by open pulses A (e.g. key-operated push-button, radio control) or by the P2 push-button:

- 1st OPEN - Leaf 1 opening deceleration start.
- 2nd OPEN - Leaf 1 opening stop and start of leaf 2 opening movement.

As an alternative to the open, allow the leaf to reach its opening stop point.
 3rd OPEN - Leaf 2 opening deceleration start.
 4th OPEN - Leaf 2 opening stop and immediate start of leaf 2 closing movement. As an alternative to the open, allow the leaf to reach its opening stop point.
 5th OPEN - Leaf 2 closing deceleration stop.
 When the leaf has reached its closing stop point, the closing movement of leaf 1 starts immediately.
 6th OPEN - Leaf 1 closing deceleration start. Allow the leaf to reach its closing stop point.
 The learning procedure has finished.

Procedure for single-leaf gate

While the function 5 LEDs are lighted steadily, hold down push-button P2 for about 3 seconds - operator 1 (master) starts the opening manoeuvre; the following functions are commanded either by open pulses A (e.g. key-operated push-button, radio control) or by the P2 push-button:
 1st OPEN - Leaf deceleration start.
 2nd OPEN - Leaf opening stop (alternatively, allow the leaf to reach its opening stop point) and immediate closing reverse.
 3rd OPEN - Leaf deceleration start. Allow the leaf to reach its closing stop point.
 The learning procedure has finished.

Controlling leaf 1 with either Master or Slave card

With this function, you can select the leaf you wish to move with the Master card.
 Press and hold down push-button P1, then press push-button P2. LED A starts flashing. Using push-button P2, move from LED 1 to LED2 according to the type of leaf control you require, as described below:
 -LED 1 lighted: the Master card commands leaf 1 (Default).
 LED 2 lighted: the Master card commands leaf 2.
 NOTE: the operation of the Slave card is automatically set, according to how the Master card was programmed.

Table 5

Programming	
LED	Function
A	Function logic (see tables 6/a, 6/b, 6/c and 6/d) 1 = A (automatic) 2 = S (safety) 3 = AP (stepped automatic) 4 = EP (stepped semi-automatic) (Default)
B	Pause times 1 = 5 seconds (Default) 2 = 10 seconds 3 = 20 seconds 4 = 30 seconds
C	Opening / Closing delays 1 = op 0 sec./cl 0 sec. 2 = op 2 sec./cl 2 sec. 3 = op 2 sec./cl 4 sec. (Default) 4 = op 2 sec./cl 8 sec.
D	Static force 1 = low 2 = medium low 3 = medium high (Default) 4 = high
E	Speed 1 = low 2 = medium low (Default) 3 = medium high 4 = high

15. AUTOMATION TEST

When installation has been completed, run a careful functional check of the automated system and all accessories connected to it, especially the safety devices. Hand the "User's guide" page to the Customer, and explain correct operation and use of the operator.

16. MANUAL OPERATION

If the gate has to be moved manually due to a fault of the automated system, use the release device as follows:

- Fit the supplied Allen wrench in the front part of the operator and turn it clockwise for 5 turns (fig. 30).
- Lift the operator by its front end, detaching it from the fitting.

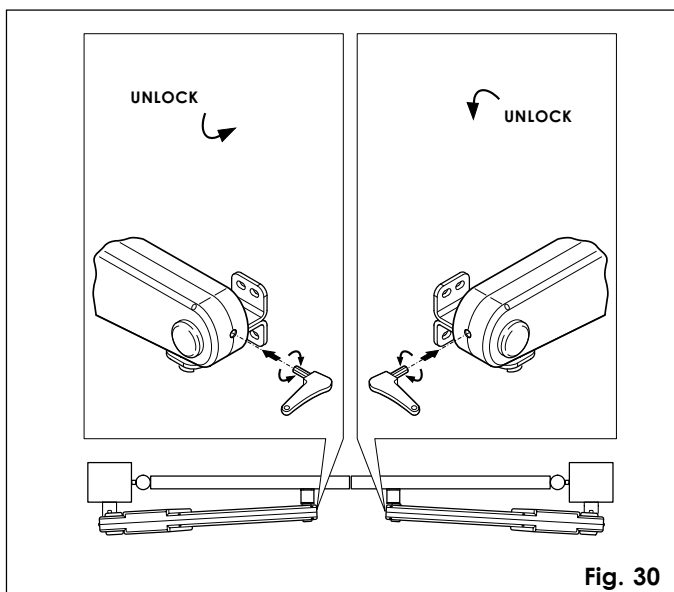

Fig. 30

17. RESTORING NORMAL OPERATION MODE

- Re-position the operator on the front fitting so that the groove of the pin coincides with the mechanical stop on the bush (fig. 31).

18. MAINTENANCE

- Carry out the following jobs at least every six months:
- Check if the anti-crushing device is correctly adjusted.
 - Check the efficiency of the release system.
 - Check the efficiency of safety devices and accessories.

19. REPAIRS

For any repairs, contact the authorised Repair Centres.

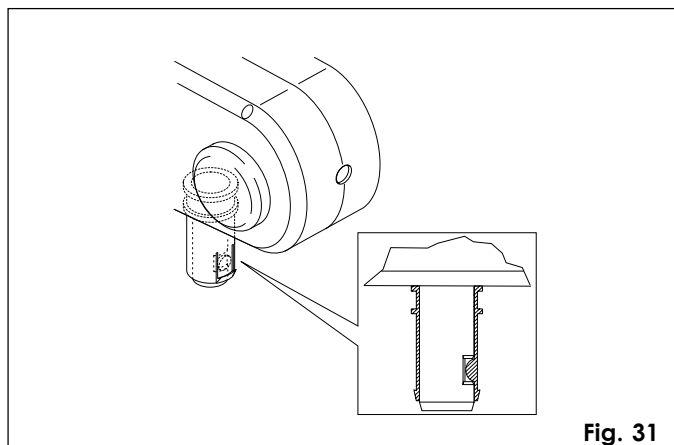

Fig. 31

Tab. 6/a

LOGIC "A"				PULSES			
GATE STATUS	OPEN-A	OPEN B	STOP	OPENING SAFETY DEVICES	CLOSING SAFETY DEVICES	OP/CLS. SAFETY DEVICE	
CLOSED	Opens leaf/ves and re-closes after pause time		No effect (OPEN disabled)	No effect (OPEN disabled)	No effect	No effect (OPEN disabled)	
OPEN on PAUSE	Re-loads pause time		Stops operation	No effect	Re-loads pause time		
AT CLOSING	Re-opens the leaf/ves immediately			No effect	Locks and, on release, reverses at opening		
AT OPENING	No effect		Inverts movement immediately	No effect	Inverts movement immediately		
LOCKED	Closes the leaf/ves		No effect	No effect	No effect (OPEN disabled)		

Tab. 6/b



LOGIC "S"				PULSES			
GATE STATUS	OPEN-A	OPEN B	STOP	OPENING SAFETY DEVICES	CLOSING SAFETY DEVICES	OP/CLS. SAFETY DEVICE	
CLOSED	Opens leaf/ves and re-closes after pause time		No effect (OPEN disabled)	No effect (OPEN disabled)	No effect	No effect (OPEN disabled)	
OPEN on PAUSE	Re-closes the leaf/ves immediately		Stops operation	No effect	Closes after 5" (OPEN disabled)		
AT CLOSING	Re-opens the leaf/ves immediately			No effect	Inverts movement immediately	Inverts movement immediately	
AT OPENING	Re-closes the leaf/ves immediately		Inverts movement immediately	No effect	Inverts movement immediately		
LOCKED	Closes the leaf/ves		No effect	No effect	No effect (OPEN disabled)		

Tab. 6/c

LOGIC "AP"				PULSES			
GATE STATUS	OPEN-A	OPEN B	STOP	OPENING SAFETY DEVICES	CLOSING SAFETY DEVICES	OP/CLS. SAFETY DEVICE	
CLOSED	Opens leaf/ves and re-closes after pause time		No effect (OPEN disabled)	No effect (OPEN disabled)	No effect (OPEN disabled)	No effect (OPEN disabled)	
OPEN on PAUSE	Stops operation		Stops operation	No effect	Re-loads pause time		
AT CLOSING	Re-opens the leaf/ves immediately			No effect	Inverts movement immediately		
AT OPENING	Stops operation		Locks and reverses to close at release	No effect	No effect	Inverts movement immediately	
LOCKED	Closes the leaf/ves		No effect	No effect	No effect (OPEN disabled)		

Tab. 6/d

LOGIC "EP"				PULSES			
GATE STATUS	OPEN-A	OPEN B	STOP	OPENING SAFETY DEVICES	CLOSING SAFETY DEVICES	OP/CLS. SAFETY DEVICE	
CLOSED	Opens leaf/ves		No effect (OPEN disabled)	No effect (OPEN disabled)	No effect	No effect (OPEN disabled)	
OPEN	Re-closes the leaf/ves immediately		Stops operation	No effect	No effect (OPEN disabled)		
AT CLOSING	Stops operation			Inverts movement immediately	Inverts movement immediately	Inverts movement immediately	
AT OPENING	Stops operation		Inverts movement immediately	No effect	No effect	Inverts movement immediately	
LOCKED	Restarts moving in reverse direction		No effect (OPEN disabled)	No effect (if it must open, it disables OPEN)	No effect	No effect (OPEN disabled)	

<p>DICHIARAZIONE CE DI CONFORMITÀ PER MACCHINE (DIRETTIVA 89/392 CEE, ALLEGATO II, PARTE B)</p> <p>Fabbricante: GENIUS s.r.l. Indirizzo: Via Padre Elzi, 32 24050 - Grassobbio BERGAMO - ITALIA</p> <p>Dichiara che: L'Attuatore mod. ACTION</p> <ul style="list-style-type: none"> è costruito per essere incorporato in una macchina o per essere assemblato con altri macchinari per costituire una macchina ai sensi della Direttiva 89/392/CEE, e successive modifiche 91/368/CEE, 93/44/CEE, 93/68/CEE; è conforme ai requisiti essenziali di sicurezza delle seguenti altre direttive CEE: 73/23/CEE e successiva modifica 93/68/CEE, 89/336 CEE e successiva modifica 92/31/CEE e 93/68/CEE <p>e inoltre dichiara che <u>non è consentito mettere in servizio il macchinario</u> fino a che la macchina in cui sarà incorporata o di cui diverrà componente sia stata identificata e ne sia stata dichiarata la conformità alle condizioni della Direttiva 89/392/CEE e successive modifiche trasposta nella legislazione nazionale dal DPR n° 459 del 24 Luglio 1996.</p> <p>Grassobbio, 1 Marzo 2002</p> <p>L'Amministratore Delegato D. Gianantoni </p>	<p>EC MACHINE DIRECTIVE COMPLIANCE DECLARATION (DIRECTIVE 89/392 EEC, APPENDIX II, PART B)</p> <p>Manufacturer: GENIUS s.r.l. Address: Via Padre Elzi, 32 24050 - Grassobbio BERGAMO - ITALY</p> <p>Hereby declares that: the ACTION</p> <ul style="list-style-type: none"> is intended to be incorporated into machinery, or to be assembled with other machinery to constitute machinery in compliance with the requirements of Directive 89/392 EEC, and subsequent amendments 91/368 EEC, 93/44 EEC and 93/68 EEC; complies with the essential safety requirements in the following EEC Directives: 73/23 EEC and subsequent amendment 93/68 EEC, 89/336 EEC and subsequent amendments 92/31 EEC and 93/68 EEC. <p>and furthermore declares that <u>unit must not be put into service</u> until the machinery into which it is incorporated or of which it is a component has been identified and declared to be in conformity with the provisions of Directive 89/392 EEC and subsequent amendments enacted by the national implementing legislation.</p> <p>Grassobbio, 1 March 2002</p> <p>Managing Director D. Gianantoni </p>	<p>DÉCLARATION CE DE CONFORMITÉ (DIRECTIVE EUROPÉENNE "MACHINES" 89/392/CEE, ANNEXE II, PARTIE B)</p> <p>Fabricant: GENIUS s.r.l. Adresse: Via Padre Elzi, 32 24050 - Grassobbio BERGAMO - ITALIE</p> <p>Déclare d'une part que l'automatisme mod. ACTION</p> <ul style="list-style-type: none"> est prévue soit pour être incorporée dans une machine, soit pour être assemblée avec d'autres composants ou parties en vue de former une machine selon la directive européenne "machines" 89/392 CEE, modifiée 91/368 CEE, 93/44 CEE, 93/68 CEE. satisfait les exigences essentielles de sécurité des directives CEE suivantes: 73/23 CEE, modifiée 93/68 CEE, 89/336 CEE, modifiée 92/31 CEE et 93/68 CEE. <p>et d'autre part qu'il est formellement interdit de mettre en fonction l'automatisme en question avant que la machine dans laquelle il sera intégrée ou dont il constituera un composant ait été identifiée et déclarée conforme aux exigences essentielles de la directive européenne "machines" 89/392/CEE, et décrets de transposition de la directive.</p> <p>Grassobbio, le 1 Mars 2002</p> <p>L'Administrateur Délégué D. Gianantoni </p>
<p>DECLARACIÓN DE CONFORMIDAD CE PARA MÁQUINAS (DIRECTIVA 89/392 CEE, ANEXO II, PARTE B)</p> <p>Fabrizante: GENIUS s.r.l. Dirección: Via Padre Elzi, 32 24050 - Grassobbio BERGAMO - ITALIA</p> <p>Declara que: El equipo automático mod. ACTION</p> <ul style="list-style-type: none"> Ha sido construido para ser incorporado en una máquina, o para ser ensamblado con otros mecanismos a fin de constituir una máquina con arreglo a la Directiva 89/392 CEE y a sus sucesivas modificaciones 91/368 CEE, 93/44 CEE y 93/68 CEE. Cumple los requisitos esenciales de seguridad establecidos por las siguientes directivas CEE: 73/23 CEE y sucesiva modificación 93/68 CEE, 89/336 CEE y sucesivas modificaciones 92/31 CEE y 93/68 CEE. <p>Asimismo, declara que <u>no está permitido poner en marcha el equipo</u> si la máquina en la cual será incorporado, o de la cual se convertirá en un componente, no ha sido identificada o no ha sido declarada su conformidad a lo establecido por la Directiva 89/392 CEE y sus sucesivas modificaciones, y a la ley que la incorpora en la legislación nacional.</p> <p>Grassobbio, 1º de Marzo de 2002.</p> <p>Administrador Delegado D. Gianantoni </p>	<p>EG-KONFORMITÄTserklärung zu MASCHINEN (gemäß EG-Richtlinie 89/392/EWG, Anhang II, Teil B)</p> <p>Hersteller: GENIUS s.r.l. Adresse: Via Padre Elzi, 32 24050 - Grassobbio BERGAMO - ITALIEN</p> <p>erklärt hiermit, daß: der Antrieb Mod. ACTION</p> <ul style="list-style-type: none"> zum Einbau in eine Maschine oder mit anderen Maschinen zu einer Maschine im Sinne der Richtlinie 89/392 EWG und deren Änderungen 91/368 EWG, 93/44 EWG, 93/68 EWG vorgesehen ist. den wesentlichen Sicherheitsbestimmungen folgender anderer EG-Richtlinien entspricht: 73/23 EWG und nachträgliche Änderung 93/68 EWG 89/336 EWG und nachträgliche Änderung 92/31 EWG sowie 93/68 EWG <p>und erklärt außerdem, daß die <u>Inbetriebnahme solange untersagt ist</u>, bis die Maschine, in welche diese Maschine eingebaut wird oder von der sie ein Bestandteil ist, den Bestimmungen der Richtlinie 89/392 EWG sowie deren nachträglichen Änderungen entspricht.</p> <p>Grassobbio, 1 März 2002</p> <p>Der Geschäftsführer D. Gianantoni </p>	<p>CE VERKLARING VAN OVEREENSTEMMING VOOR MACHINES (RICHTLIJN 89/392/EEG, BIJLAGE II, DEEL B)</p> <p>Fabrikant: GENIUS s.r.l. Adres: Via Padre Elzi, 32 24050 - Grassobbio BERGAMO - ITALIE</p> <p>verklaart dat: de aandrijving mod. ACTION</p> <ul style="list-style-type: none"> is gebouwd voor opname in een machine of voor assemblage met andere machines, met het doel een machine te vormen in de zin van de Richtlijn 89/392/EEG en latere wijzigingen 91/368/EEG, 93/44/EEG, 93/68/EEG; in overeenstemming is met de fundamentele veiligheidsisen van de volgende EEG-richtlijnen: 73/23/EEG en latere wijziging 93/68/EEG, 89/336/EEG en latere wijziging 92/31/EEG en 93/68/EEG <p>en verklaart bovendien dat het <u>niet is toegestaan de machine in bedrijf te stellen</u> voordat de machine waarin zij wordt opgenomen of waarvan zij onderdeel wordt, geïdentificeerd is, en de overeenkomstigheid ervan verklaard is volgens de voorwaarden van de Richtlijn 89/392/EEG en latere wijzigingen, die in de nationale wetgeving zijn omgezet door het Presidentieel Besluit nr. 459 van 24 juli 1996.</p> <p>Grassobbio, 1 Maart 2002</p> <p>President - directeur D. Gianantoni </p>

GENIUS®

GENIUS s.r.l.
Via Padre Elzi, 32
24050 - Grassobbio
BERGAMO-ITALY
tel. 0039.035.4242511
fax. 0039.035.4242600
info@geniusg.com
www.geniusg.com

Le descrizioni e le illustrazioni del presente manuale non sono impegnative. GENIUS si riserva il diritto, lasciando inalterate le caratteristiche essenziali dell'apparecchiatura, di apportare in qualunque momento e senza impegnarsi ad aggiornare la presente pubblicazione, le modifiche che essa ritiene convenienti per miglioramenti tecnici o per qualsiasi altra esigenza di carattere costruttivo o commerciale.

The descriptions and illustrations contained in the present manual are not binding. GENIUS reserves the right, while leaving the main features of the equipments unaltered, to undertake any modifications to hold necessary for either technical or commercial reasons, at any time and without revising the present publication.

Les descriptions et les illustrations du présent manuel sont fournies à titre indicatif. GENIUS se réserve le droit d'apporter à tout moment les modifications qu'elle jugera utiles sur ce produit tout en conservant les caractéristiques essentielles, sans devoir pour autant mettre à jour cette publication.

Las descripciones y las ilustraciones de este manual no comportan compromiso alguno. GENIUS se reserva el derecho, dejando inmutadas las características esenciales de los aparatos, de aportar, en cualquier momento y sin comprometerse a poner al día la presente publicación, todas las modificaciones que considere oportunas para el perfeccionamiento técnico o para cualquier otro tipo de exigencia de carácter constructivo o comercial.

Die Beschreibungen und Abbildungen in vorliegendem Handbuch sind unverbindlich. GENIUS behält sich das Recht vor, ohne die wesentlichen Eigenschaften dieses Gerätes zu verändern und ohne Verbindlichkeiten in Bezug auf die Neufassung der vorliegenden Anleitungen, technisch bzw. konstruktiv / kommerziell bedingte Verbesserungen vorzunehmen.

De beschrijvingen en illustraties in deze handleiding zijn niet bindend. GENIUS behoudt zich het recht voor om op elk willekeurig moment, en zonder verplicht te zijn deze publicatie bij te werken, de wijzigingen aan te brengen die wenselijk geacht worden met het oog op technische verbeteringen of om andere redenen van technische of commerciële aard, waarbij de essentiële eigenschappen van de apparatuur ongewijzigd blijven.

Timbro rivenditore:
Distributor's stamp:
Timbre de l'agent:
Sello del revendedor:
Fachhändlerstempel:
Stempel van de dealer:

