

1. Mount the alu carrier and drill holes at points spaced 300-500mm apart minimum.

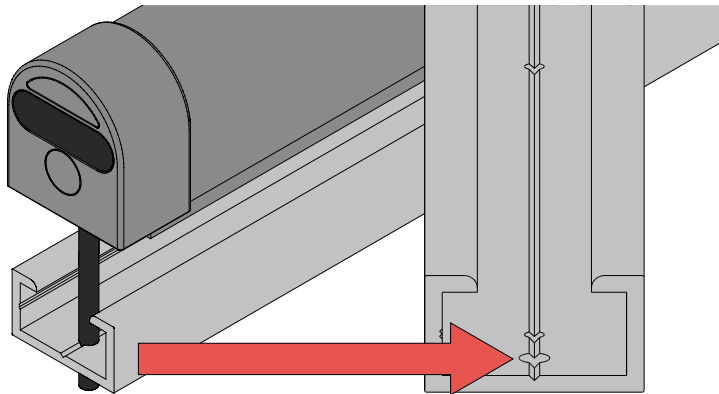

3. Drill an additional 8mm hole in the desired location to draw any cables through the alu carrier and frame of gate/door.

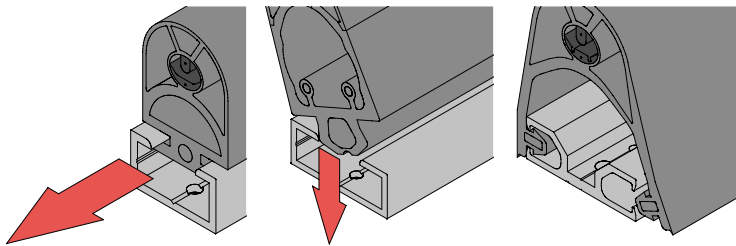

5. Fit the safety edge to the carrier as illustrated (edges with **T foot** slide in) (edges with a **C foot** clip in from above) (edges with a **Clip foot**, clip over from either side of the safety edge).

6. !WARNING! do not attempt to pull T foot or C foot edges in to the carrier using the attached cables, this can damage the edges assembly and will invalidate any warranty

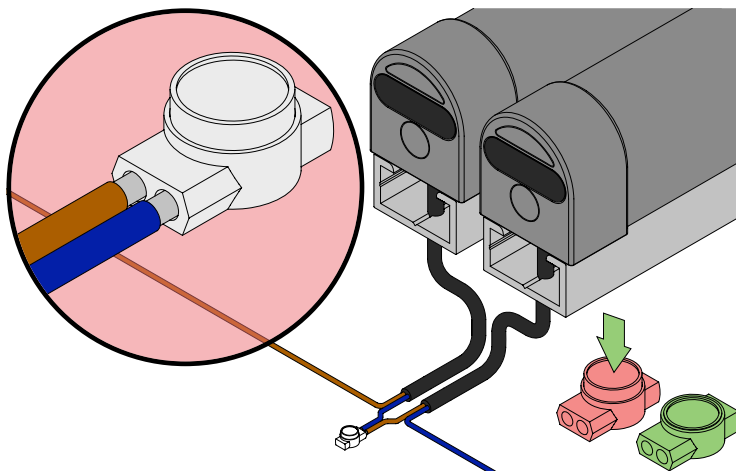

8. When joining cables between safety edges or junction boxes, be sure to use weather proof connectors such as gel crimps or properly soldered and heatshrunk connectors rated at IP 65 or above **!WARNING!** Failure to join cables properly will invalidate any warranty of the safety edge.

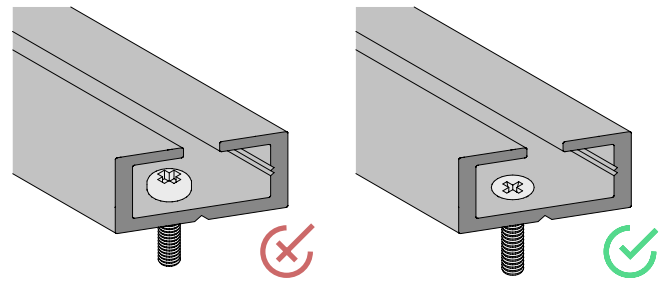

2. Use pan headed or counter sunk screws where possible to prevent snagging of the rubber edge profile on exposed screw heads.

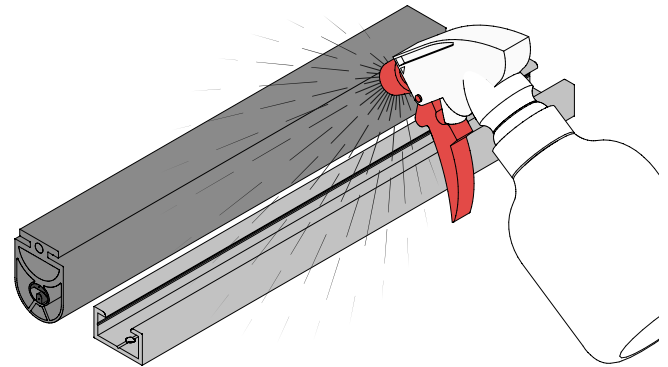

4. Use a soapy water spray solution to coat the rubber foot of the safety edge profile and the alu carrier before attempting to install the safety edge.

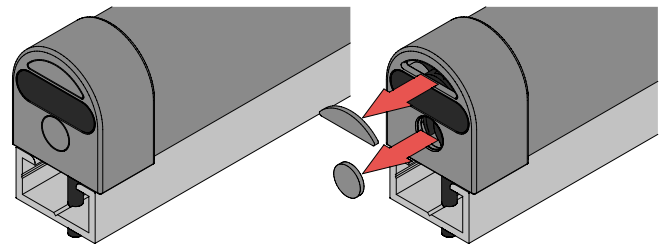

7. Finally ensure that water drains from the end caps have been removed as illustrated (for vertical installations remove only the lower water drain (for horizontal installations remove water drains from both ends of the safety edge) **!WARNING!** failure to remove water drains from the safety edge will invalidate any warranty.

STORAGE AND HANDLING METHODS

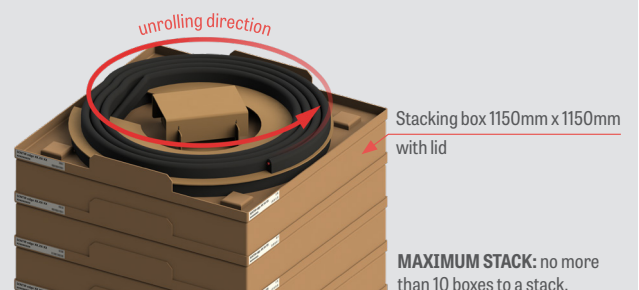

ASO edge material for self-assembly **MUST** be stored in a cool, dry environment away from sources of water or heavy contaminants. Before attempting to assemble contact edges the material should be checked thoroughly for moisture or contaminants and cleaned and dried appropriately.

DO NOT tightly coil or place heavy objects on top of the safety edge materials, this can cause damage to the profile and will invalidate any warranty.

MANUFACTURERS LIMITED WARRANTY

SENTIR
edge

WARRANTIES AND DISCLAIMERS

Easygates Ltd, Inc. ("Seller") warrants that the product will be free from substantial defects in material and workmanship, and will substantially perform in accordance with the technical specifications set forth in the description of the product for the duration of the warranty period specified below.

The warranty period is twenty four (24) months from the date of purchase. Proof of date of purchase must be provided when attempting to make any warranty claim.

The product (i) may be newly manufactured, (ii) may be assembled from new or serviceable used parts that are equivalent to new parts in performance, or (iii) may have been previously installed. During the warranty period, Seller will repair or replace any defective item of the product or parts or components of the product promptly reported to Seller by customer and which Seller determines was defective due to a warranty defect. In the event that Seller determines, in its reasonable discretion, that the defect in a product was not caused by customer or a third party, Seller shall, at its option, either provide customer with a refund or credit for the purchase price paid or provide a suitable replacement of the same (or similar) type to customer for the defective product.

Seller may, at its own discretion and costs, elect to first attempt to repair any defect at Seller's facilities in Halesowen, West Midlands and thereafter, at Seller's discretion, travel to customer's location. Labor costs of diagnosis are not included in this warranty. Under no circumstances shall the repair of any product result in an extension of the warranty period granted herein. Customer shall not attempt to repair or resolve any product without the prior consent of Seller. Any attempt by customer to repair or resolve any product without the prior consent of Seller shall void this warranty. Because the product requires on-going maintenance, the preceding warranty is not a substitute for maintenance services or other support service by Seller.

The warranty as to the product does not cover any defect under warranty attributable in whole or in part to (i) non-Seller products and services, and any interfaces or links of such to the products, alterations of out-of-specification supplies, (ii) accidents, misuse, negligence or failure of customer to follow instructions for proper use, care and cleaning of the product, (iii) external factors (e.g., failure or fluctuation of electrical power or air conditioning, fire, flood), or (iv) failure by customer to comply with Seller's specifications.

EXCEPT AS EXPRESSLY STATED AND SET FORTH HEREIN, THERE ARE NO WARRANTIES OR REPRESENTATIONS, EXPRESS OR IMPLIED, CONCERNING THE PRODUCT AND NO SUCH WARRANTIES OR REPRESENTATIONS SHALL BE IMPLIED UNDER ANY APPLICABLE LAW, IN EQUITY OR OTHERWISE, INCLUDING WITHOUT LIMITATION, A WARRANTY OF MERCHANTABILITY, A WARRANTY OF FITNESS FOR A PARTICULAR PURPOSE, OR ANY OTHER WARRANTY WHICH MAY BE IMPLIED UNDER COMMON LAW.

STORAGE & HANDLING

All rubber profile materials should be stored in a cool, dry place away

from moisture (e.g. not outdoors). Before assembly/fitting of the rubber profile, it should be checked thoroughly for any signs of damage or water ingress. If damage is present the rubber profile should not be used.

LIMITATION OF LIABILITY

Unless further limited elsewhere in this Agreement, the entire liability of Seller and customer's exclusive remedy for damages from any cause related to or arising out of a warranty defect, regardless of the form of action, whether in contract or in tort, will not exceed the amount of the purchase price for each purchase order for the product which is the subject matter or directly related to the causes of action asserted.

In no event will Seller, its agents, subcontractors, suppliers and employees be liable for (a) any incidental, indirect, special or consequential damages, including, but not limited to, loss of use, revenue, profits or savings, substitute rental or for any other reason, even if Seller knew or should have known of the possibility of such losses or damages, (b) claims, demands or actions against customer by any person, except as provided by applicable law.

CREDIT SUSPENSION / PAYMENT ACCELERATION

Seller may at will suspend performance of any order, declare a debt's entire balance due or require payment in cash, collateral as security or other adequate assurances satisfactory to seller including but not limited to payment in advance when, because of the financial condition the customer or otherwise seller deems its position regarding the prospect of payment insecure.

CUSTOMER'S CANCELLATION / RETURN OF PRODUCTS

Orders accepted by seller and subsequently canceled by customer for reasons beyond control of seller are subject to cancellation charges. As to products returned to seller, customer is limited to credit allowance or replacement if the returned item is deemed to contain defects as described in the previous section of this document. CASH REFUNDS WILL NOT BE GIVEN under any circumstances. No returns will be accepted without a "Return Authorization Number", this number must be clearly visible on all packages. Return numbers can be obtained by telephone, fax or e-mail form Easygates Ltd directly.

RISK OF LOSS

Deliveries of the products are made FOB place of shipment and risk of loss passes to customer upon delivery of the products to the carrier at the point of shipment. Transportation shall be at customer's sole risk and expense and any claim for loss or damage in transit shall be against the carrier only.

CLERICAL ERRORS

Seller has the right to correct any stenographic or clerical errors in any of the writings issued by it and is not responsible for the content of such error.