

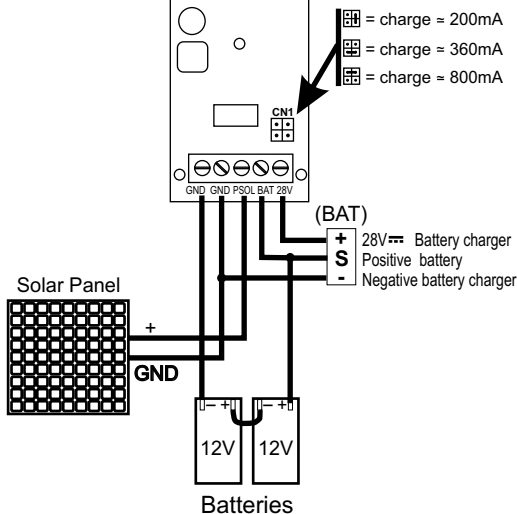

E SUN

Cod.23101105



E SUN Q

Cod.23101104

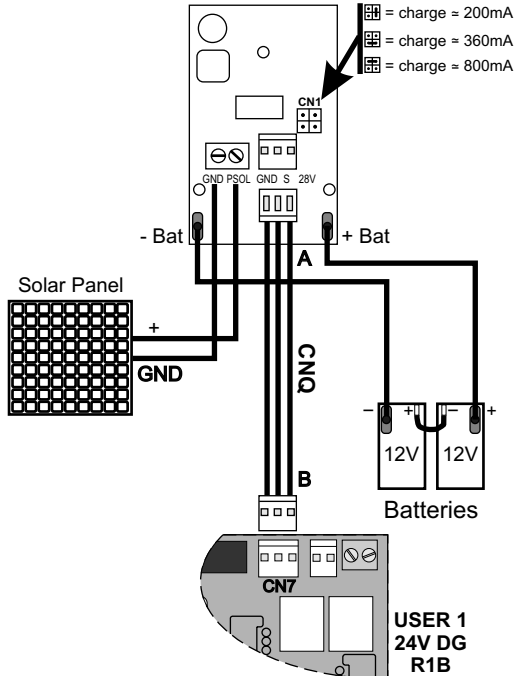

Caso 1: se si dispone della centrale USER 1 24V DG R1B e del precedente modello di caricabatterie (senza innesto rapido), è necessario utilizzare il cavo adattatore CNQ opportunamente tagliato in corrispondenza del punto A.

Caso 2: se si dispone di carica batterie con innesto rapido E SUN- Q e di centrali elettroniche non predisposte per innesto rapido, occorre tagliare il cavo adattatore CNQ in corrispondenza del punto B.

Case 1: if you have a USER 1 24V DG R1B control unit and the previous battery charger model (without quick connection) you must use the CNQ cable connector correctly cut at point A.

Case2: if you have a battery charger with quick connection E SUN-Q and control units which are not predisposed for quick connection, you must cut the CNQ connector cable at point B.



IMPORTANTE: per collegare le batterie utilizzare sempre il caricabatterie.

IMPORTANT: To connect the batteries, always use the battery charger.

Corrente di batteria (mA) Battery current (mA)	Batteria (Ah) Battery (Ah)
800	12 o/ or 16
360	7
200	2

Caratteristiche
batterie opzionali:
**Specifications of
optional batteries:**

24V Pb 1.2Ah min.

Inserire due batterie da 12V collegate in serie.
Insert two 12V batteries connected in series.