

GENERAL & OPERATIONAL INFORMATION

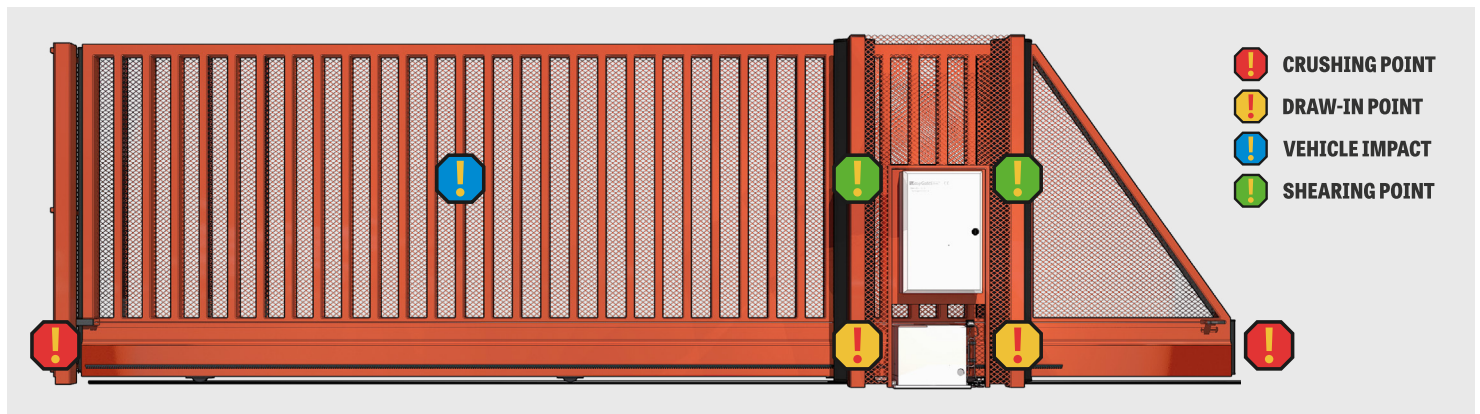

The **ELMON rail relay** is designed for use on sliding gates/doors & machine solutions. The relay evaluates pressure sensors fitted to the systems, including safety contact mats, safety contact strips and safety bumpers, reducing the risk of crush and shearing points.

Four separate sensor circuits can be connected to the **Rail 71-242/942** switching unit, whereby they are combined in to two directional switching outputs.

Monitoring of the standby current is made possible by an integrated terminating resistor in the sensor circuit. If the specified standby current is flowing, the output relay is activated and the switching contact is closed. If a sensor is actuated or a sensor circuit is interrupted, the relay switching contact opens.

The relay is designed in accordance with **EN ISO 13849-1:2008** for **Category 3 PI e**. To comply with Category 3 for compliance, the safety output is set up redundantly with two independent switching elements which are resilient to a single point of failure.

The monitoring state of the sensors and the applied operating voltage are indicated by LEDs on the front of the unit.

In the event of a fault alarm, all safety outputs are inactive.

PROPER USE

The **ELMON rail 71-242 (ELMON rail 71-942)** switching unit can only fulfill its safety-related task if used properly.

The ELMON rail **71-242 (ELMON rail 71-942)** safety transmission system is designed for evaluating stationary and traveling safety contact edges with constant **8.2 kΩ resistance**.

Any uses above and beyond these guidelines constitutes improper use. The manufacturer assumes no liability for damages arising from improper use.

The device may only be used in special applications with the manufacturer's express consent.

SYSTEM COMPONENTS FITTED TO THE GATE

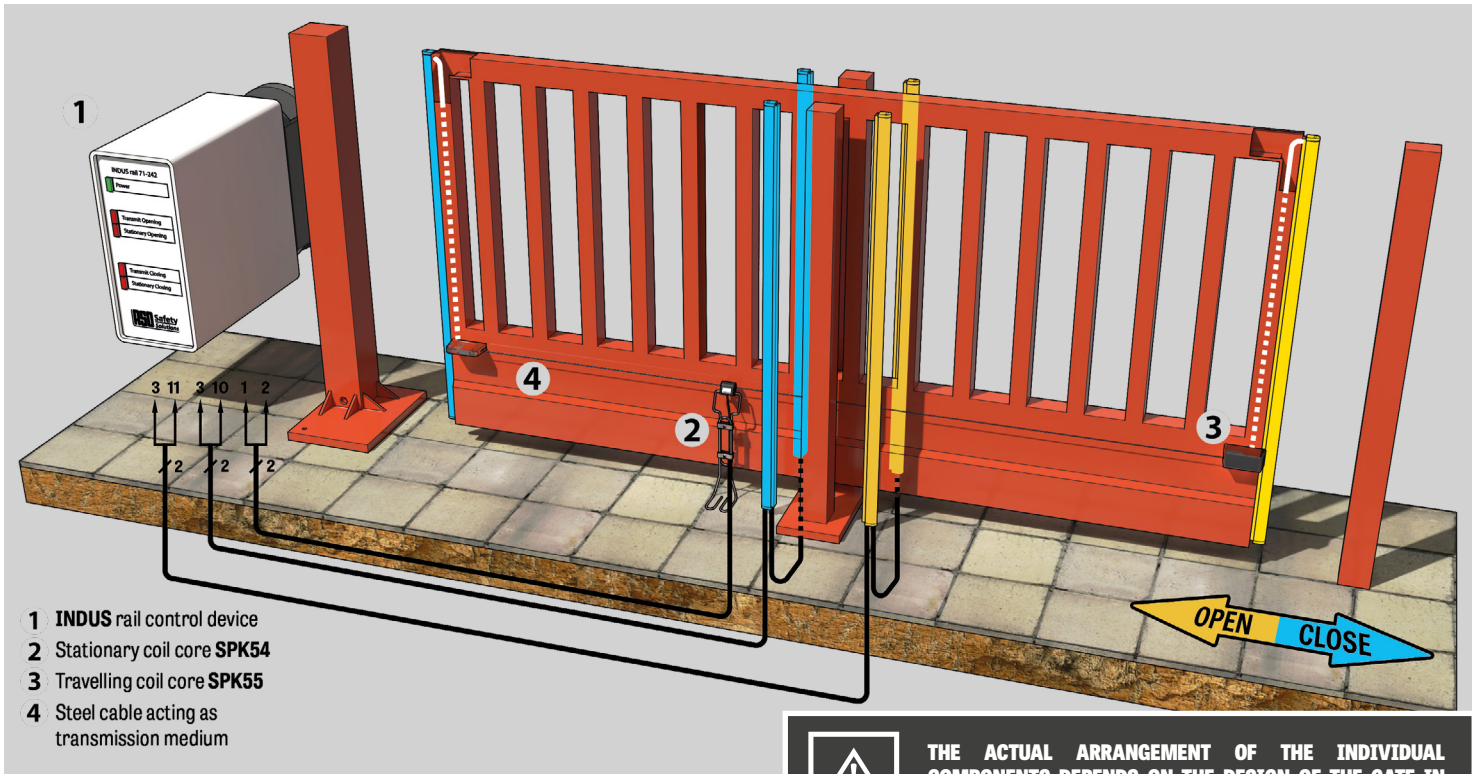

THE ACTUAL ARRANGEMENT OF THE INDIVIDUAL COMPONENTS DEPENDS ON THE DESIGN OF THE GATE IN QUESTION AND THE CONDITIONS AT THE INSTALLATION SITE.

DEVICE OVERVIEW

Signal Displays

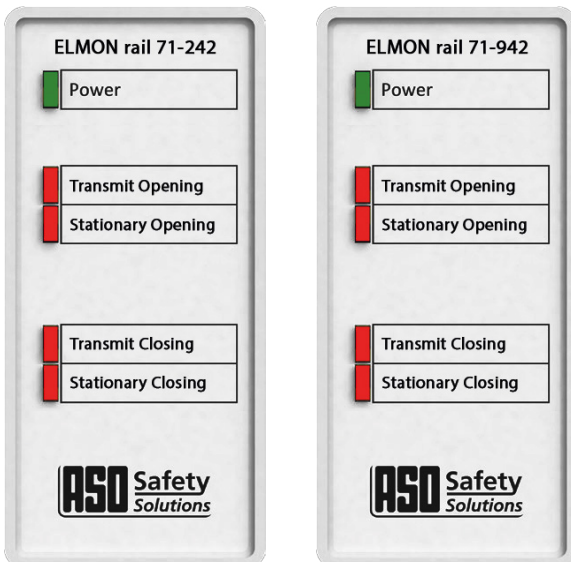

During the output of an error message, the number of output pulses indicates the error:

LED POWER (green)

Operation mode (on) - **OK**

Fault alarm (pulse) - **see error diagnostics**

LED TRANSMIT OPENING (red)

Fault, opening movement - **travelling edge(s)**

LED STATIONARY OPENING (red)

Fault, opening movement - **stationary edge(s)**

LED TRANSMIT CLOSING (red)

Fault, closing movement - **travelling edge(s)**

LED STATIONARY CLOSING (red)

Fault, closing movement - **stationary edge(s)**



V3.1> If no error is present, then LED Power shows the function control (briefly off).

V4.0 and later: If no error is present, then LED Power shows the operating state (on).

Pulse	Error message diagnostics
1	Voltage supply outside of the valid value range (24V AC/DC +/- 10%)
2	ELMON coils/wire transmission error (see troubleshooting page)
3	Output control Open faulty (replace unit)
4	Output control Close faulty (replace unit)
5	Data transmission with micro-controller faulty (replace unit)
6	Error in testing signal input (see troubleshooting page 9)

FITTING GUIDE

So far, the cable of the contact edge (**OPEN/CLOSE**) had to be installed along the gates entire length to connect it to the travelling coil core (**SPK 54**).

A new steel cable with an **additional 2 cores** is now included in each kit, which helps reduce fitting time. One end is pre-assembled with connectors for the travelling coil. An extra pair of waterproof connectors is included at the tensioner to connect the rear travelling safety edge.

This allows safety edges at each end of the gate to be connected to the travelling coil easily, without the need to run a long connecting cable through or along the gate.

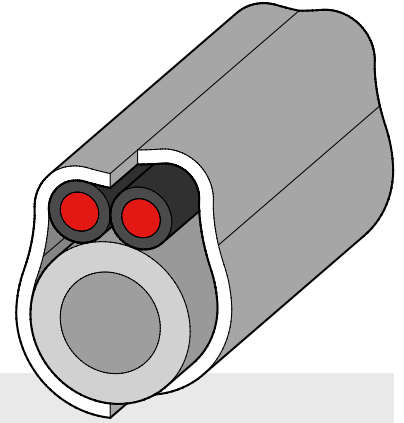

COMPONENTS

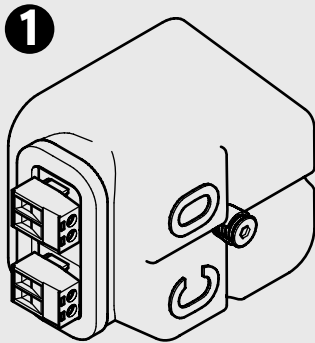

SPK 54 S Mount

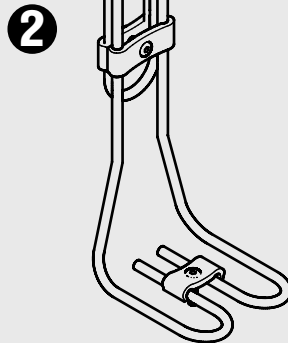

SPK 55 Coil Core

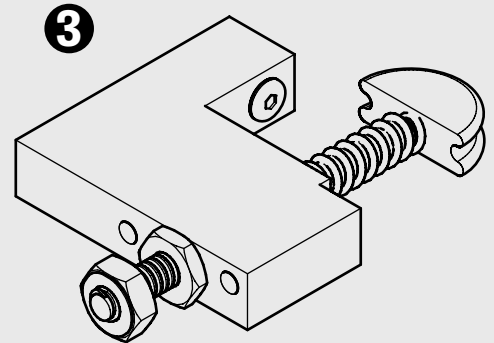

Tension Bracket Mount

REQUIRED TOOLS

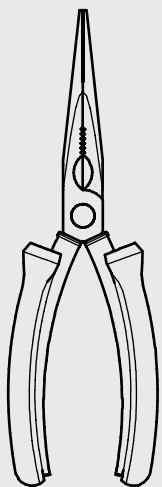

Cutters

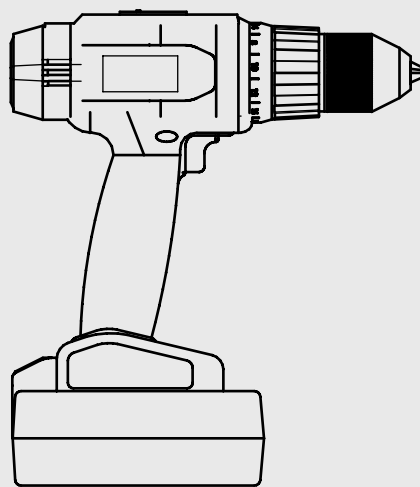

Drill



M4 & M6 Tap bits

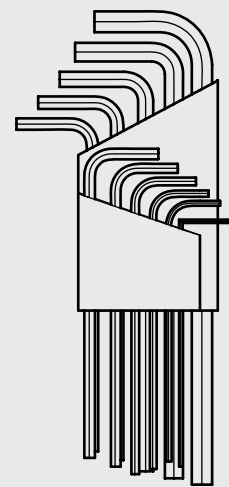

Allen Keys

FITTING GUIDE

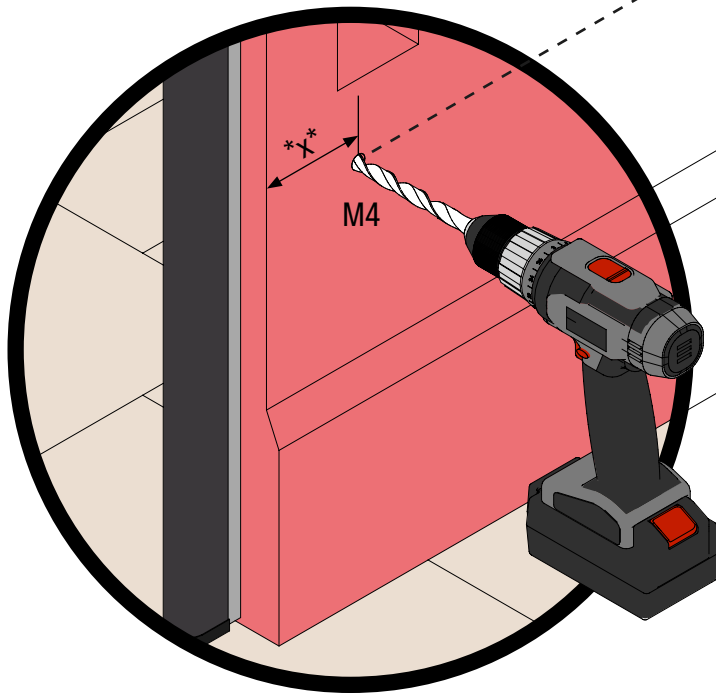
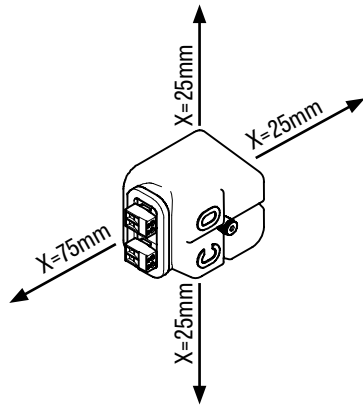

1A Drill and tap M4 Hole

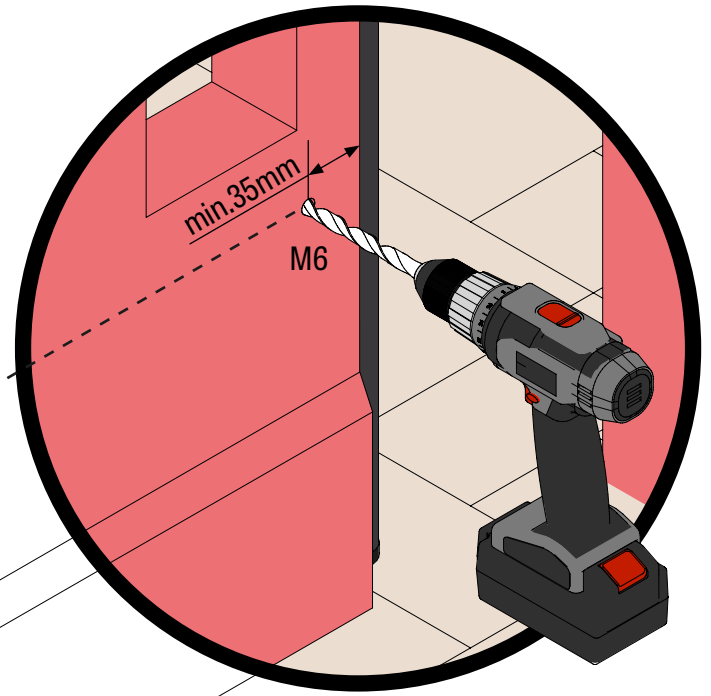

3A Drill and tap M6 Hole or bolt/tek screw

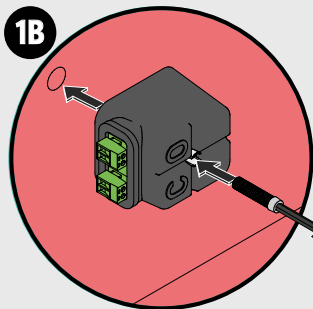

Screw in the provided allen head bolt.
!DO NOT OVER TIGHTEN!
1,5-2 Nm

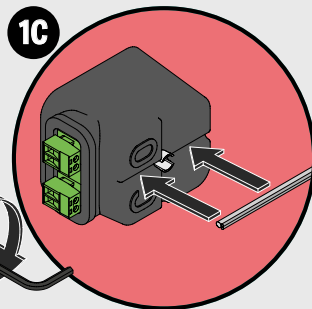

Place the transmission cable in slot gap.

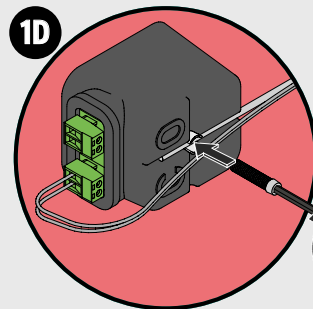

Strip back the insulation and plug cable cores into plug terminals.
!ONLY CLAMP THE STEEL CABLE!
1,5-2 Nm

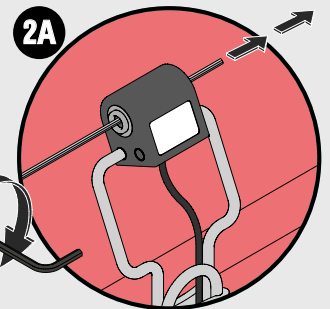

Pass the cable through the stationary SPK coil.

FITTING GUIDE

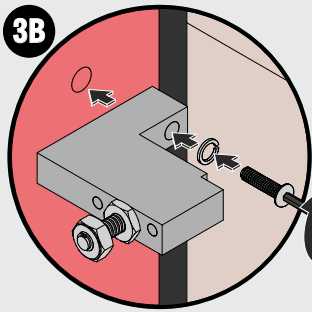

Fix tension bracket with an M6 or a similar bolt.
1,5-2 Nm

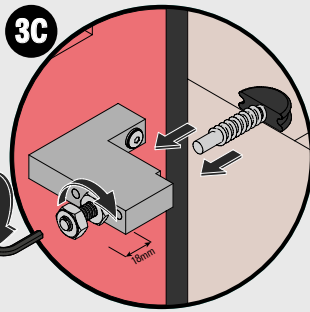

Fit the clamping unit into the tension bracket

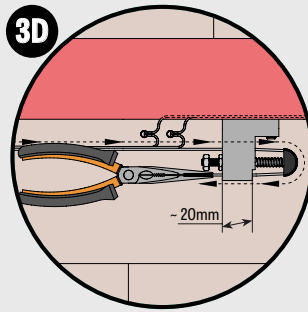

Pull the Cable through the tension bracket and clamp.
!CABLE SHOULD NOT BE LOOSE!

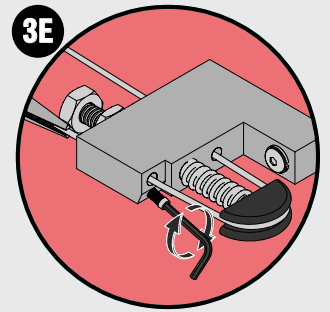

Clamp down the allen head screw.
**!DO NOT OVER TIGHTEN!
1,5 Nm**

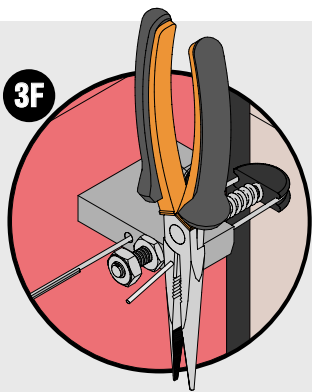

Trim away excess steel cable.

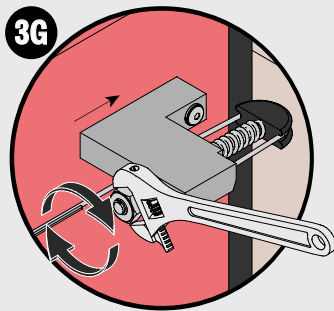

Adjust the clamp unit.

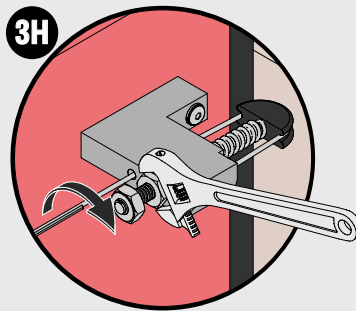

Tighten the clamp unit to hold everything in place.
1,5-2 Nm

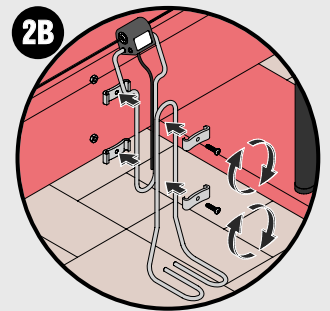

Secure SPK coil bracket appropriately.

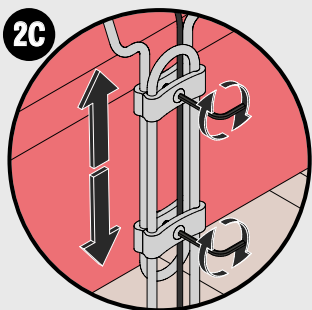

Adjust for height.
1,5 Nm

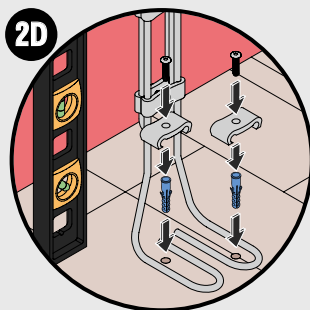

Adjust for position and secure to the ground.

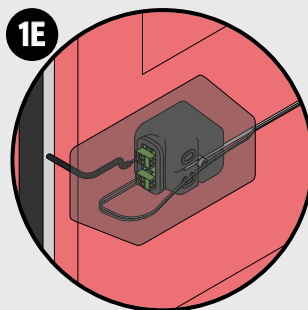

Cover the components for protection.

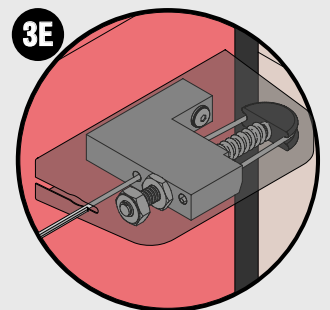

Cover the tension bracket for protection.

CONNECTION TERMINALS

ELMON rail 71-242

Pin 12	Stationary coil, SPK54/5
Pin 3 11	SCE - Leading pillar - Opening
Pin 3 10	SCE - Leading pillar - Closing
Pin 4 5	Relay output for controller - stop opening
Pin 6 7	Relay output for controller - stop closing
Pin 8 9	Supply voltage, 24V 24V +/- 10%

ELMON rail 71-942

Pin 4 5	Transmit
Pin 6 7	Stationary open
Pin 8 9	Stationary close

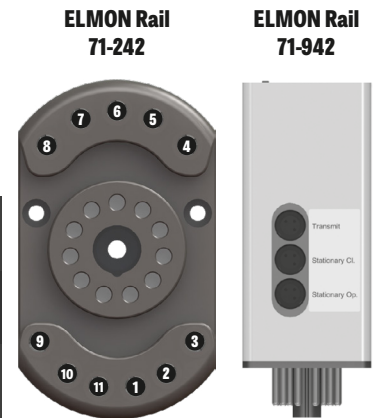

CONNECTING THE DEVICE

Prerequisites

- The supply voltage used for the ELMON rail 71-242 and the ELMON rail 71-942 must comply with the requirements for safety low voltage (SELV).
- Cables installed outdoors or outside of the switching cabinet must be protected appropriately.
- The protection class specified for this device is only ensured if the supply lines have been properly clamped to the screw connections.

ELMON Rail 71-242

Supply Voltage

With the **ISK 71-242** and **ISK 71-942**, 24 V AC/DC is to be connected to terminal pair **8, 9** as voltage supply. The supply line to the switching unit must be protected with an appropriate fuse.

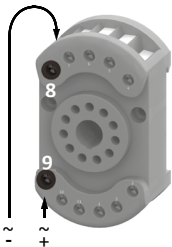

Connecting the stationary coil core - SPK54/5

ELMON rail 71-242: Connect the stationary coil core to terminal pair **1, 2**; no special attention is required for polarity.

ELMON rail 71-942: The stationary coil core is to be connected to the **Transmit** slot. The cable for the coil core is connected using the supplied crimp connectors or by directly soldering the wire to the connectors.

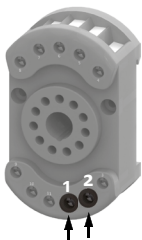

Connecting the stationary contact edges

ELMON rail 71-242: The stationary safety contact edge(s) (SCE) on the leading pillar for the opening movement is (are) connected to terminal pair **3, 11**.

ELMON rail 71-942: The stationary SCE(s) for the opening movement is (are) connected to the **Stationary Opening** slot. If several SCEs are being used, they must be connected in series and the end edge must be terminated using an 8.2 kΩ resistor.

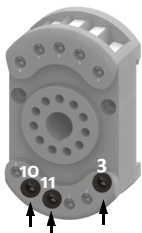

ELMON rail 71-242: The stationary SCE(s) for the closing movement is (are) connected to terminal pair **3, 10**.

ELMON rail 71-942: The stationary SCE(s) for the closing movement is (are) connected to the **Stationary Closing** slot.

If one or both channels for the stationary SCE are not used, the supplied 8.2 kΩ resistors are to be connected to the respective channels.

ELMON Rail 71-942

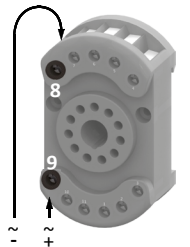



Connecting the control circuits

The control circuit to be monitored for the opening movement (stop-opening movement) is to be connected to terminal pair **4, 5**; for the closing movement (stop-closing movement), the appropriate control circuit is to be connected to terminal pair **6, 7**. The control circuits are dependent on the rated current to protect with an appropriate fuse or the rated current to the control circuits must be limited by other measures to the maximum value.



CONNECTING THE SENSORS

Connecting to the coil core SPK 54 (figure 1)

The traveling edges (SCE) are connected to the traveling coil core.

For this purpose, the traveling SCE CLOSING movement is connected to connection C of the traveling coil core and the optional SCE OPENING movement is connected to connection O.

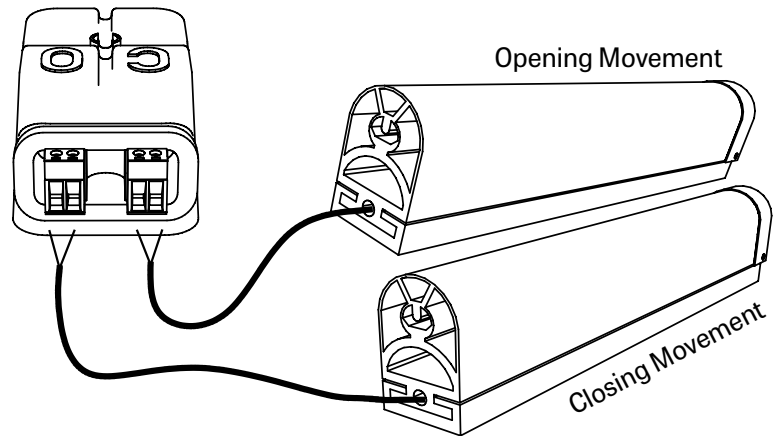

Figure 1: connection at the coil core



If a channel is not used, it must be connected to an 8,2 kΩ resistor.

CONNECTING THE SENSORS

Connecting multiple sensors per sensor circuit (figure 2)

One or more sensors can be connected to sensor input **O** or **C**. For this purpose, the individual sensors are connected in series according to figure 2.

Up to five sensors may be connected in series, whereby the total cable length must not exceed 25 m. The length of one sensor may be up to 25 m.

Before connecting the sensors that are connected in series, it is recommended that the resistance value of the arrangement be measured.

The resistance must be $8.2\text{ k}\Omega \pm 500\ \Omega$ when the SCE is inactive and must not exceed $500\ \Omega$ when it is active.



ASO sensors must not be connected in parallel.

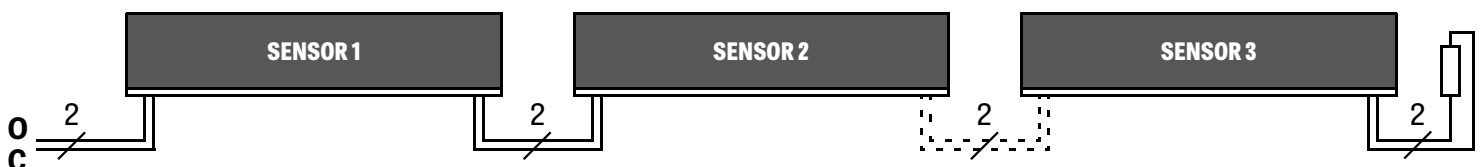
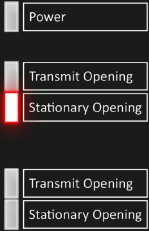
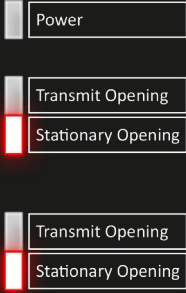

Figure 2: Wiring of multiple sensors; in this example: safety contact edge

The gate system must be tested for proper function after all of the electrical connections have been established and the supply voltage has been turned on. To do this, activate each of the safety contact edges one after another and check the corresponding reactions of the switching unit.

ERROR DIAGNOSIS

Only the **green** LED may illuminate if the supply voltage has been correctly connected. If one of the red LEDs illuminate, there is an error in the system which can be pinpointed with the aid of the LED.

LED	Error	Error correction
LEDs are not illuminated	The supply voltage is missing, too low or has been connected incorrectly	Test connections and supply voltage: - 24 V AC/DC to terminals 8 & 9, tolerance range: ±10%
<p>A single Red LED is illuminated</p> 	<p>Contact edge(s) not connected, connected incorrectly or faulty</p> <p>One of the contact edge connections is not being used</p>	<ul style="list-style-type: none"> Check connections of the relevant sensors (pinched wiring, brittle wiring etc.) Check safety contact edge(s) * <p>Any contact edge connections that are not being used must be permanently bridged using one of the supplied 8.2 kΩ resistors</p>
<p>Both Stationary RED LEDs are illuminated</p> 	<p>Sensor circuit broken, sensor not connected, connected incorrectly or faulty</p>	<ul style="list-style-type: none"> 8.2KOhms on input Before making any other checks, the first task required for you to do is meter the Ohms measured at the relay inputs across terminals 3 & 10 (Close edge input) and 3 & 11 (Opening edge input). These should be reading around 8K2Ohms. If they are reading significantly more or less than this value, then this will indicate the reason for the LED to be lit on the relay. The acceptable switching tolerances of this relay measure from 5Kohms up to 12Kohms. Anything outside of these values will result in the inputs relay opening and the relative LED showing lit on the front of the ISK71-242. If you are not reading 8K2Ohms and you have a series of safety edges wired into that circuit, then you will need to deduce which edge is causing the problem. The quickest fault finding means to achieve this is by testing each edge in series until you find 8K2. If you do not find this value at all, then you know that there is an issue with the end of line edge which will need to be addressed. Water within a safety edge Check all drainage holes have been cut at the bottom of the vertical edges and either side of the horizontal edges. Damaged edge / earthed connections Check to ensure no cables have been wearing on joints where movement may incur or in junction boxes which may have other wiring in place. Carry out a full inspection of each edge to ensure no signs of obvious damage. Cuts / Rips on the edge Check that all edges have no obvious visible signs of damage / vandalism. If the safety edge has any short or broken contact, the relay will read 0.0 Ohms and the corresponding input LED will be lit.

LED	Error	Error correction
<p>Both Transmit RED LEDs are illuminated</p> <div style="display: flex; flex-direction: column; gap: 10px;"> <div style="display: flex; align-items: center;"> <div style="width: 15px; height: 15px; background-color: #ccc; border: 1px solid #ccc; margin-right: 5px;"></div> <div style="border: 1px solid #ccc; padding: 2px;">Power</div> </div> <div style="display: flex; align-items: center;"> <div style="width: 15px; height: 15px; background-color: #f00; border: 1px solid #f00; margin-right: 5px;"></div> <div style="border: 1px solid #ccc; padding: 2px;">Transmit Opening</div> </div> <div style="display: flex; align-items: center;"> <div style="width: 15px; height: 15px; background-color: #ccc; border: 1px solid #ccc; margin-right: 5px;"></div> <div style="border: 1px solid #ccc; padding: 2px;">Stationary Opening</div> </div> <div style="display: flex; align-items: center; margin-top: 10px;"> <div style="width: 15px; height: 15px; background-color: #f00; border: 1px solid #f00; margin-right: 5px;"></div> <div style="border: 1px solid #ccc; padding: 2px;">Transmit Opening</div> </div> <div style="display: flex; align-items: center;"> <div style="width: 15px; height: 15px; background-color: #ccc; border: 1px solid #ccc; margin-right: 5px;"></div> <div style="border: 1px solid #ccc; padding: 2px;">Stationary Opening</div> </div> </div>	<p>The transmission line is faulty or has been installed incorrectly</p> <p>Contact edge(s) not connected, connected incorrectly or faulty</p>	<ul style="list-style-type: none"> • Observe the mechanical assembly instructions on page 2,3 & 4. • Check transmission coil cores for abrasion. • Check cable loop; make certain that both transmission coil cores are in the cable loop • Check cable / gate leaf contact points. • Check supply voltage** • Check for earth to the gate The ELMON kit fundamentally uses inductive technology. This requires the use of a coil and cable which MUST be earthed to the frame of the steel gate. At the one end of the gate you will have a coil which the leading and trailing edge both must wire in to. If you do not have a trailing edge, then you will need to link out the other input by means of an 8.2KOhm resistor supplied on the side of the ISK71-242. At the other end you will have a tensioning unit which keeps the cable taut so as no slack will wear away a groove in the stationary coil, or even worse, catch on any moving parts. Both the tensioning unit and the travelling coil must be making contact with the frame of the gate. Any paint or galvanization will need to be stripped back for this contact to be true. You will also need to ensure that the wire which runs the length of the gate is also earthed to the gate by means of the little grub screws on the travelling coil and the tensioning unit. They must pierce the plastic sheathing to make contact in the eventuality you find yourself with a wooden gate that you wish to apply the ELMON kit to, the best means of doing this will be to create a 'false loop' on the gate. To do this you will need to run a separate cable down the back of the gate and run this from the SPK54S (travelling coil) and attach it to the tensioning unit via whichever way is best possible according to the design of the gate. • Check for any obvious signs of damage to the SPK55 (Static coil) If the bracket for the SPK55 has not been mounted in a way where the cable that runs through it is level, then this may cause the cable to have a 'sawing' effect in the hole that it runs through. To easily prevent this, make sure that the bracket is attached to a fixed level ground using two bolts to prevent the likelihood of it pulling to one side. • Check for any obvious signs of damage to the cable running the length of the gate On many installations, the cable which is earthed to the gate will be mounted fairly low to accommodate the stationary coil which more often than not it mounted to the floor. If the gates are located somewhere where vandalism is likely to occur, then one of the most susceptible parts of the ELMON is the exposed cable. Any signs of damage should be obvious and may affect the inductive circuit. To get around this problem, you may wish to relocate the cable to a less obvious position. This can be anywhere on the gate which may offer less incentive to damage. You will need to relocate the coil however and thus make some alterations to the bracket it houses into. • Check for 8.2KOhms on the edge inputs on SPK54S travelling coil The travelling coil has two inputs. One which monitors the edge on the opening direction and one which monitors the edge for the closing direction. Both of these inputs must see 8.2KOhms. If one of the inputs has not been used, then this should be linked out with an 8.2KOhm resistor supplied on the side of the ISK relay.

LED	Error	Error correction
<p>Power Green LED flashes cyclically (pulse)</p>	<p>6 pulses from power LED - this code can be caused by a number of issues</p>	<ul style="list-style-type: none"> • Water within a safety edge Check all drainage holes have been cut at the bottom of the vertical edges and either side of the horizontal edges. • Damaged edge / earthed connections Check to ensure no cables have been wearing on joints where movement may incur or in junction boxes which may have other wiring in place. Carry out a full inspection of each edge to ensure no signs of obvious damage. • ISK relay has been housed / positioned next to high EMF I.E. large transformer. In some installations, a separate cabinet may not have been fitted to house other electrical components. This may result in the ISK relay sharing the same housing as the mains transformer for the motor. In some cases this has caused the circuitry of the relay to fail. Remove the relay from the motors housing and reset the power to check for improvement. • Cabling has been shared with DC voltage apparatus which is causing interference. Check that the safety edges are not sharing the same cabling / conduits with anything which may be carrying a DC mains or pulse voltage. This may result in the static edge inputs (3,10 & 3,11) having a back feed of interference which the controller identifies as a fault.

* If the error is not in the wiring, the function of the electronics can be tested by connecting an 8.2 kΩ resistor to all SCE inputs on the ELMON rail 71-242 (ELMON rail 71-942) electronic evaluation system (terminals **3, 10** and terminals **3, 11**) and to the traveling coil core (connections **O** and **C**). If the electronics work perfectly after performing the test, the safety contact edges must be checked using an ohmmeter. To do this, the respective connection on the SCE for the electronic evaluation system or for the traveling coil core must be disconnected and connected to an ohmmeter.

** The resistance must be 8.2 kΩ ±500 Ω when the safety contact edge is inactive and must not exceed 500 Ω when it is active.

If both of the LEDs for the traveling SCEs (**Transmit Opening** and **Transmit Closing**) illuminate, there is an error in the inductive signal transmission system. The most frequent causes of these errors are bad coil core connections, incorrectly installed cable system components (see ELMON rail safety transmission system assembly instructions) or an impermissible low supply voltage.

The maximum resistance value of the cable loop must not exceed 3 Ω . The resistance value can be measured by disconnecting the steel cable from the ground

TECHNICAL DATA



EC type-examination no.:
44 205 12 399386

Certificate no.:
44 780 12 399386

Test report no.:
12 205 399386-000

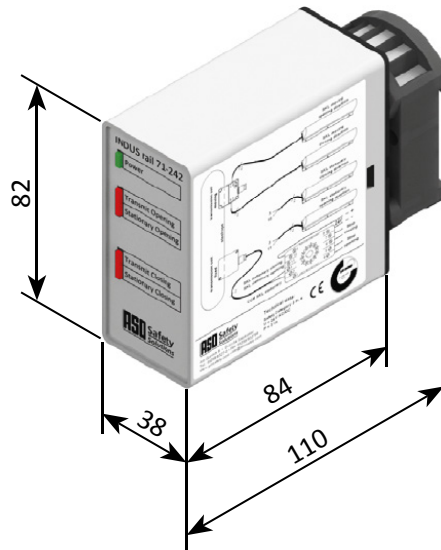

ELMON RAIL 71-242

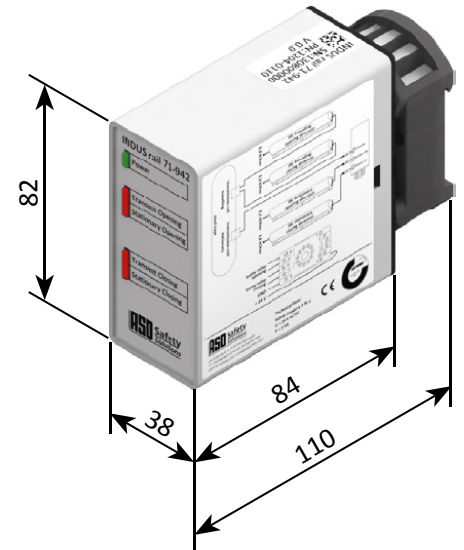

ELMON RAIL 71-942

Supply Voltage

Low Voltage:	U_E	24V AC/DC \pm 10%
	I_E	85mA
	I_{max}	180mA (100ms)

Terminal Resistance of the SCEs

		Stationary SCE	Travelling SCE
nominal value	R_{nom}	= 8,2 k Ω	= 8,2 k Ω
upper switching point	R_{AO}	> 12,0 k Ω	> 20,0 k Ω
lower switching point	R_{AU}	< 5,0 k Ω	< 2,5 k Ω

Relay Stages

Nominal current DC	3 A (30 V DC)
Nominal current AC	3 A (30 V AC)
Mechanical life-time	>10 ⁶ actuations

Safety Relay Switching Times

	Stationary SCE	Travelling SCE
Switching off delay	<10 ms	<30 ms
Switching on delay	500 ms (Power on 700 ms)	

Assembly	Plug base for 35 mm DIN snap-on rail mounting
Housing	11-pin DIN plug-base housing with plug base for 35 mm mounting rail (DIN rail)
Dimensions (HxWxD)	
Housing	82 x 38 x 84 mm
Housing (incl. plug in socket)	82 x 38 x 110 mm
Protection Class	IP20
Weight	225g
Temperature Range	-25°C to + 55°C
Connection Cable cross-section	Single or fine-stranded cable 0.75 -1.5mm ²
Certifications	DIN EN ISO 3849-1:2008 Category 3 PL e
	MTTFd 170 years, DC 91%
Electronics	MTTFd 1616 years, DC 99 %
Electromechanics	B10d 1000000
	MTTFd 190 years (Nop 52560)
Safety device acc. to	DIN EN 12978

All voltages connected to the switching unit must be safely isolated