

INDEX

1	BOX LAYOUT.....	2
2	WARNINGS.....	3
3	LAYOUT AND CONNECTIONS.....	3
4	TECHNICAL SPECIFICATIONS	4
4.1	DESCRIPTION OF COMPONENTS.....	4
4.2	DESCRIPTION OF TERMINAL-BOARDS.....	4
5	PROGRAMMING THE LOGIC.....	4
6	PROGRAMMING THE SPEED.....	4
7.	START-UP.....	5
7.1	LEDS CHECK.....	5
7.2	DIPS-SWITCH PROGRAMMING.....	5
7.3	PRE-FLASHING.....	5
7.4	TIME LEARNING - SET-UP.....	5
7.4.1	AUTOMATIC SET-UP.....	5
7.4.2	MANUAL SET-UP.....	5
8	INSTALLATION OF BUS ACCESSORIES.....	6
8.1	ADDRESSING BUS ENCODER.....	6
8.2	ADDRESSING THE BUS PHOTOCELLS.....	6
8.3	MEMORY STORAGE OF BUS ACCESSORIES.....	7
9	MEMORY STORING THE RADIO CODE.....	7
9.1	MEMORY STORAGE OF DS RADIO CONTROLS.....	8
9.2	MEMORY STORAGE OF SLH RADIO CONTROLS.....	8
9.3	MEMORY STORAGE OF LC RADIO CONTROLS (for some markets only).....	8
9.3.1	REMOTE MEMORY STORAGE OF LC RADIO CONTROLS.....	9
9.4	RADIO CONTROLS DELETION PROCEDURE.....	9
10	CONNECTION OF BUFFER BATTERIES (OPTIONAL).....	9
10.1	BATTERY KIT.....	9
11	AUTOMATED SYSTEM TEST.....	9
12	LOGIC TABLES.....	10

CE DECLARATION OF CONFORMITY

Manufacturer: FAAC S.p.A.
Address: Via Benini, 1 - 40069 Zola Predosa BOLOGNA - ITALY
Declares that: Control board mod. E 700,



- conforms to the essential safety requirements of the following EEC directives:
 73/23/EEC and subsequent amendment 93/68/EEC.
 89/336/EEC and subsequent amendment 92/31/EEC and 93/68/EEC

Additional information:
 This product underwent a test in a typical, uniform configuration
 (all products made by FAAC S.p.A)

Bologna, 01 January 2007.

 The Managing Director
A. Bassi

WARNINGS

- Important! For the safety of people, it is important that all the instructions be carefully observed.
- Incorrect installation or incorrect use of the product could cause serious harm to people.
- Carefully read the instructions before beginning to install the product and keep them for future reference.
- The symbol  indicates notes that are important for the safety of persons and for the good condition of the automated system.
- The symbol  draws your attention to the notes on the characteristics and operation of the product.

ELECTRICAL BOX E700

1 BOX LAYOUT

⚠ The box contains the E700 electronic unit and the devices to power it. It must therefore be handled with care during all installation stages, to avoid damaging its components.

The dimensions of the box are shown in Fig.1:

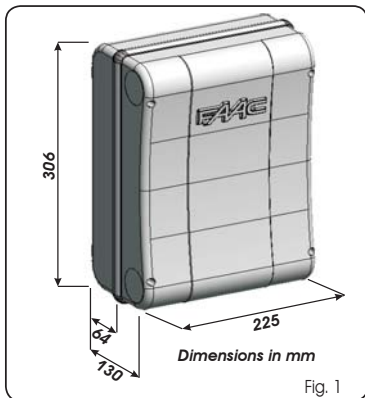
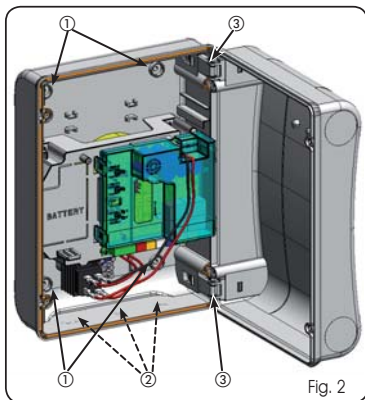
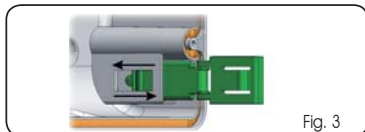

Fig. 2 shows the four 5 mm diam. holes for securing the box (ref.①) to the wall, the three fittings M16/M20/M25 for installing the cable grippers (ref.②) and the two lid hinges (ref.③).



The lid hinges can be moved upward to allow opening the box housing (Fig. 3); they can also be removed and re-positioned in order to enable the lid to open to the right or left.



When you have secured the box in the selected position, cover the securing holes (ref.① Fig.2) and the screws with the supplied plugs as shown in Fig.4.

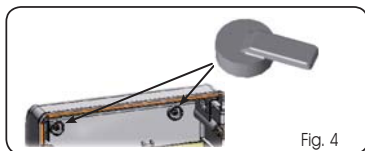

After you have finished the operations to connect the control board with the various parts of the automated system, close the box, positioning the lid in its seat with seal. Connect the supply as shown in Fig. 5.

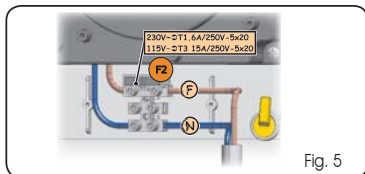

Next, tighten the four supplied screws to guarantee the degree of protection against external agents (Fig.6).



2 WARNINGS

⚠ Before attempting any work on the control unit (connections, maintenance), always turn off power.

- Install, upstream of the system, a differential thermal breaker with adequate tripping threshold,
- Always separate power cables from control and safety cables (push-button, receiver, photocells, etc.).
- To avoid any electrical disturbance, use separate sheaths or a screened cable (with the screen earthed).

3 LAYOUT AND CONNECTIONS

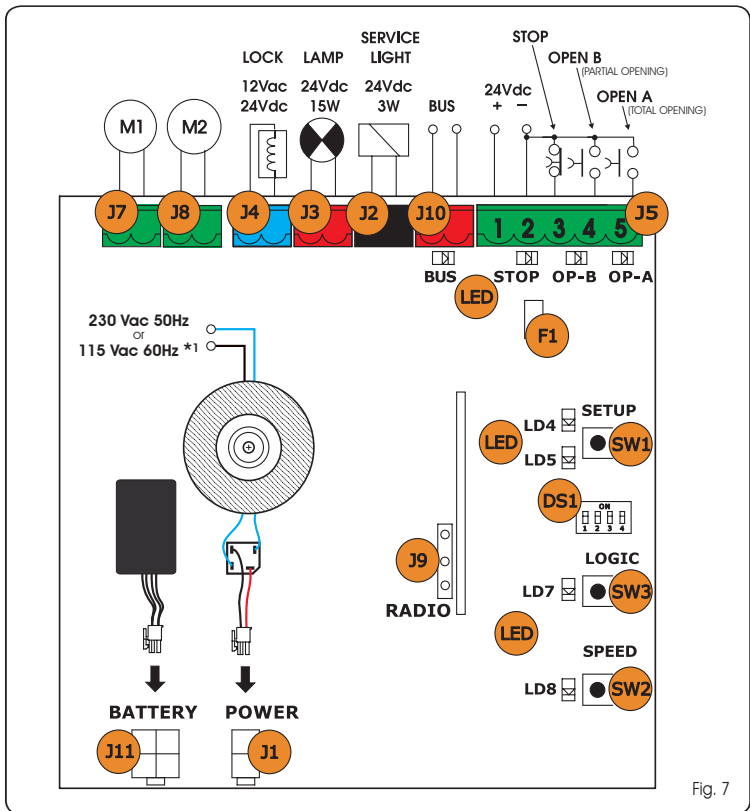

Fig. 7

⚠ *1 The power supply is related to the E700 purchased version.

4 TECHNICAL SPECIFICATIONS

Power supply voltage*2	230Vac (+6% -10%) - 50Hz or 115Vac (+6% -10%) - 60Hz.
Absorbed power	20W
Motor max. load	150W x 2
Accessories max. current (+24V)	100 mA
BUS Accessories max.current	400 mA
Operating ambient temperature	-20°C - +55°C
Fuses*2	F1 = self-resetting; F2 = T2A-250V or T4A-120V
Function logics	EP, A
Work time (time-out)	3 minute (fixed)
Pause time	Varies according to learning (max. 10 min.)
Terminal board inputs	Open A, Open B, Stop, BUS (I/O)
Connector inputs	Power supply, battery module XF 433 or XF 868
Terminal board outputs	Motors, flashing lamp, power supply to accessories, electric lock, service light contact (90 sec fixed)
Programmable functions	Logic (A, EP), Speed (high 4.8°/sec and low 3.7°/sec)
Learning functions	Pause time, leaf 2 delay at closing
Integrated radio channels type	DS, SLH (max 250 channels), LC (max 250 channels - FOR SOME MARKETS ONLY)

*2 The power supply and the fuse are related to the purchased version.

4.2 DESCRIPTION OF TERMINAL-BOARDS

Terminal and/or terminal-board	Description	Device connected	
1	J5	+24V	Power supply for accessories
2		GND	Negative
3		STOP	Device with NC contact which causes the automated system to shut down
4		OPEN B	Device with N.O contact (see chap. FUNCTION LOGICS)
5		OPEN A	
J10 RED terminal	BUS	Safety and control devices with BUS technology	
J2 GREY terminal	SERVICE LIGHT	Service Light control output (connect a relay coil at 24Vdc-100mA max)	
J3 ORANGE terminal	LAMP	Flashing lamp 24Vdc - 15W	
J4 BLUE terminal	LOCK	Electric lock 12Vdc or 24 Vdc (to be installed on leaf 1)	
J7	MOT1	Motor 1 (leaf 1)	
J8	MOT2	Motor 2 (leaf 2)	

 Leaf 1 means the leaf which opens first during the opening operation.

 The service light control is active during the entire gate opening or closing movement and for the successive 90 seconds.

4.1 DESCRIPTION OF COMPONENTS

J1	POWER SUPPLY connector
J2	SERVICE LIGHT command terminal-board
J3	FLASHING LAMP terminal-board
J4	ELECTRIC LOCK terminal-board
J5	COMMANDS terminal-board
J7	MOTOR 1 terminal-board
J8	MOTOR 2 terminal-board
J9	Rapid connection for XF MODULE
J10	BUS terminal-board
J11	BATTERY connector
SW1	SET-UP push-button
SW2	SPEED push-button
SW3	LOGIC push-button
DS1	Programming Dip-switch
F1	Accessories protective fuse
F2	Fuses protecting transformers and motors
LED	Signalling LEDs

5 PROGRAMMING THE LOGIC

The function logic can be selected at any time by pressing push-button SW3.

The selected logic is then displayed on LED LD7:

- LED on = AUTOMATIC logic (A)
- LED off = SEMIAUTOMATIC STEPPED logic (EP)

6 PROGRAMMING THE SPEED

The operating speed can be adjusted at any time by pressing push-button SW2.

The selected logic is then displayed on LED LD8:

- LED on = HIGH speed (4.8 °/sec)
- LED off = LOW speed (3.7 °/sec)

7. START-UP

7.1 LEDS CHECK

The following table shows the status of the LEDs in relation to the status of the inputs (the closed at rest automated system condition is shown in bold).

Check the status of the signalling LEDs as per table below:

Tab.1 – Operation of inputs status LEDs

LED	ON (closed contact)	OFF (open contact)
STOP	Command disabled	Command enabled
OPEN A	Command enabled	Command disabled
OPEN B	Command enabled	Command disabled
BUS	See par. 8.3	

7.2 DIPS-SWITCH PROGRAMMING

The following tables show the settings of the DS1 dip-switches for programming encoder sensitivity, reverse thrust, and operator force.

Tab. 2 - DS1 programming (the default settings are shown in bold)

DS1	DS2	DS3	DS4	Description
ON	ON			HIGH FORCE
ON	OFF			MEDIUM - HIGH FORCE
OFF	ON			MEDIUM - LOW FORCE
OFF	OFF			LOW FORCE
		ON		HIGH ENCODER SENSITIVITY
		OFF		LOW ENCODER SENSITIVITY
			ON	REVERSE THRUST ON
			OFF	REVERSE THRUST OFF

 If you connect an electric lock to terminal J4, position DS4 to ON to enable the reversing stroke (before opening, the motors thrust to close, thus facilitating the electric lock to uncouple).

 If you set dip-switch DS3 to OFF, a special function is enabled, allowing the gate to operate also in the event of wind gusts.

7.3 PRE-FLASHING

The pre-flashing function can be activated and disabled (following an OPEN command, the unit activates the flashing lamp for 3 seconds before it starts the movement). Procedure:

- Press LOGIC key (SW3) for at least 5 secs. to **ACTIVATE** pre-flashing.
- Press SPEED key (SW2) for at least 5 secs. to **DESACTIVATE** pre-flashing.

 In both cases check if the LED of the pressed key changes its status: in such cases it means that the function of the key and not the pre-flashing was changed.

7.4 TIME LEARNING - SET-UP

 Before any movement is executed, the Encoders must be wired as explained on chapter 8.1 page 6.

 Before any manoeuvre is executed, a SETUP cycle must first be run.

 During SETUP do not interrupt the photocells because their interruption causes the immediate stop of the leaves. To end the procedure, repeat SETUP from the beginning.

When the board is powered up and a SET-UP cycle has never been executed, LEDs LD4 and LD5 begin to flash slowly to signal that a SET-UP cycle must be executed. There are two possible types of SETUP: AUTOMATIC and MANUAL

7.4.1 AUTOMATIC SET-UP

To execute an AUTOMATIC SET-UP, follow the procedure below:

- Take the leaves to mid-opening (very important).
- Hold down the SET-UP (SW1) push-button until the 2 adjacent LEDs (LD4 and LD5) light up on steady beam.
- Release the SETUP push-button, LEDs LD4 and LD5 begin to flash rapidly.
- Leaf 2 (if present) starts the closing movement, stopping when it reaches the closing mechanical stop.
- Leaf 1 starts the closing movement, stopping when it reaches the closing mechanical stop.
- Leaf 2 (if present) starts the opening movement after the Leaf 1 stops opening.
- Leaf 2 (if present) stops when it reaches the opening mechanical stop.
- Wait for LEDs LD4 and LD5 to go OFF, which means that the SETUP procedure has finished.
- Give an OPEN pulse to close the gate.

 When the SET-UP procedure has been started, if the leaves at point 4 and 5 open instead of closing, the motor power supply cables must be changed over.

 When using the AUTOMATIC SET-UP, the slow down spaces, the leaf opening and closing delays, and the pause time (30 sec., with A logic), are all preset by the board and cannot be modified.

7.4.2 MANUAL SET-UP

To execute a MANUAL SET-UP, follow the procedure below:

- Take the leaves to mid-opening (very important).
- Hold down the SET-UP (SW1) push-button until the leaf starts moving.
- Release the SET-UP push-button, LEDs LD4 and LD5 begin to flash rapidly
- Leaf 2 (if present) starts the closing movement, stopping when it reaches the closing mechanical stop
- Leaf 1 starts the closing movement, stopping when it reaches the closing mechanical stop
- Leaf 1 starts the closing movement, stopping when it reaches the closing mechanical stop.
- Leaf 2 (if present) starts the opening movement the after Leaf 1 stops opening.
- Leaf 2 (if present) stops when it reaches the opening mechanical stop.
- If LOW force was set, wait for about 5 sec checking if the flashing lamp goes OFF.

10. If the A Logic was selected, the board begins to count the pause time (max 10 min) and, after the required time has elapsed, give an OPENING pulse to continue the procedure. Otherwise, if you have selected the EP logic, give an OPEN pulse to continue the procedure.
11. Leaf 2 (if present) starts the closing movement on the board begins to count the delay of the leaf 1 at closing.
12. After the required time has elapsed, give an OPEN pulse to make leaf 1 start the closing movement. If leaf 2 is not present, the pulse given in point 9 directly makes leaf 1 close.
13. Leaves 1 and 2 (if present) stop when they reach the closing mechanical stop.
14. Wait for LEDs LD4 and LD5 to go OFF, which means that the SETUP procedure has finished.

When the SET-UP procedure has been started, if the leaves at point 4 and 5 open instead of closing, the motor power supply cables must be changed over.

When using the MANUAL SET-UP, the slow-down spaces, and leaf delays at opening are preset by the board and cannot be modified. However, delay at leaf closing and pause time can be programmed during learning.

8 INSTALLATION OF BUS ACCESSORIES

This board is supplied with a BUS circuit enabling easy connection of a high number of BUS accessories (e.g. up to 16 photocells pairs), using only two cables.

Below we describe the addressing and memory storage of the encoders and BUS photocells.

For other future accessories, refer to the specific instructions.

8.1 ADDRESSING BUS ENCODER

Connection of the BUS input to the control board is via the bipolar cables which come out of the encoders.

Unlike the case of the photocell devices, the polarity of the BUS line connection determines whether the encoder belongs to one leaf rather than the other.

This is why you must pay great attention to the indications of the status LEDs on the body of each encoder (Fig.8).

Below we list the functions of LEDs LD1, DL2, and DL3, and their statuses:

Tab. 3 - Encoder connection and LED status

LED	LIGHTED	FLASHING	OFF
DL 1	Power ON and BUS communicating with board	Power ON but BUS not communicating	No Power or BUS communication
DL 2	Leaf 1 encoder	/	Leaf 2 encoder
DL 3	Leaf not moving	Pulses read while leaf moving	Leaf not moving

- **DL 1** must always be lighted to guarantee correct connection between encoder and board.
- **DL 2** determines the leaf on which the encoder is installed. Providing the configuration is correct, the automated system will show: an encoder with DL 2 lighted in the leaf 1, and an encoder with DL 2 OFF in the leaf 2. If there is an incorrect connection, i.e. indicating two encoders with the same status of the DL 2 LEDs, during the learning procedure of the BUS accessories, the DL 1 LEDs of both encoders show the FLASHING status. In this situation, refer to the configuration in TAB.3 to define which encoder connection to rotate.
- **DL 3** indicates, on a steady flashing beam, the reading of the pulses while the leaf is moving. When the leaf is motionless, DL 3 can be either lighted or OFF. N.B. in particular motionless leaf positions, DL3 may flutter considerably. This signal must not be considered a fault.

8.2 ADDRESSING THE BUS PHOTOCELLS

Important: the same address must be given to both transmitter and receiver.

Make sure that there are no two or more photocells pairs with the same address.

If no BUS accessory is used, leave the BUS connector free (J10 - Fig. 7).

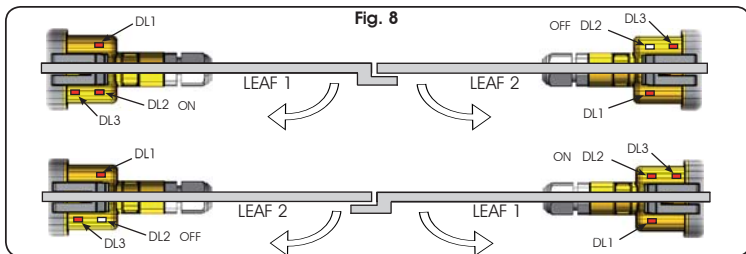

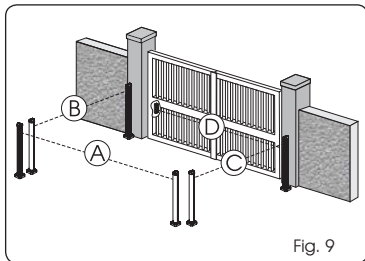

Fig. 9

A maximum of 16 BUS photocell pairs can be connected to the board.

The photocells are split into groups:

Opening photocells:	max 6
Closing photocells:	max 7
Opening /Closing photocells:	max 2
Photocell used as an OPEN pulse:	max 1

Fig. 9 shows a 2-swing leaf automated system indicating the coverage beams of the photocells:

A: Photocells with OPENING and CLOSING action

B: Photocells with OPENING action

C: Photocells with OPENING action

D: Photocells with CLOSING action

Table 4 shows the programming operations of the dip-switch inside the transmitter and of the BUS Photocells receiver.

Tab. 4 - Addressing of BUS Photocells

Dip1	Dip2	Dip3	Dip4	Ref.	Type
OFF	OFF	OFF	OFF	B - C	OPENING
OFF	OFF	OFF	ON		
OFF	OFF	ON	OFF		
OFF	OFF	ON	ON		
OFF	ON	ON	OFF		
OFF	ON	ON	ON		
ON	OFF	OFF	OFF	D	CLOSING
ON	OFF	OFF	ON		
ON	OFF	ON	OFF		
ON	OFF	ON	ON		
ON	ON	OFF	OFF		
ON	ON	OFF	ON		
ON	ON	ON	OFF		
OFF	ON	OFF	OFF	A	OPENING and CLOSING
OFF	ON	OFF	ON		
ON	ON	ON	ON	/	OPEN PULSE

8.3 MEMORY STORAGE OF BUS ACCESSORIES

You can add the BUS photocells to the system at any time, simply by memory-storing them on the board, observing the following procedure:

1. Install and program the accessories using the required address (see paragraph 8.2)
2. Cut power to the board.
3. Connect the two accessories cables to the red terminal-board J10 (any polarity will do).
4. Power up the board, taking care to first connect the main power supply (transformer output) and then any batteries.
5. Quickly press once only the SW1 (SET-UP) push-button, to execute learning. The BUS LED flashes.
6. Give an OPEN impulse, leaves will move and the BUS learning procedure is over.

The board has memory stored the BUS accessories. Follow the instructions in the table below to check if the BUS connection is correct.

Tab. 5 - Description of BUS LED

Steady light	Normal operation (LED ON even in the absence of photocells)
Slow flashing lamp (flash every 0.5 sec)	At least one input engaged: photocell engaged or not aligned, Open A or Open B or Stop input engaged
Light OFF (flash every 2.5 sec)	BUS line short circuited
Fast flashing lamp (flash every 0.2 sec)	If you have detected a BUS connection error, repeat the acquisition procedure. If the error is repeated, make sure that there is not more than one accessory with the same address in the system (also see the accessories instructions)

9 MEMORY STORING THE RADIO CODE

The control board has an integrated 2-channel decoding system (DS, LSH, LC) named OMNIDEC. This system makes it possible to memory-store both total opening (OPEN A) and partial opening (OPEN B) of the automated system - this is made possible by an additional receiver module (Fig.10 ref. ①) and radio controls on the same frequency.

The 3 types of radio codes (DS, LSH, LC) cannot coexist.

Only one radio code can be used at a time. To change over from one code to another, you must delete the existing one (see paragraph on deletion), and repeat the memory-storage procedure.

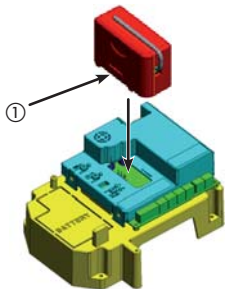

Fig. 10

9.1 MEMORY STORAGE OF DS RADIO CONTROLS

A maximum of two codes can be stored. One on the OPEN A channel and one on the OPEN B channel

1. On the DS radio control, select the required ON-OFF combination for the 12 dip-switches.
2. Press the LOGIC (SW3) or SPEED (SW2) push-button, to memory store respectively total opening (OPEN A) or partial opening (OPEN B), and as you hold it down, also press the SETUP (SW1) push-button. The relevant LED starts to flash slowly for 5 sec.
3. Release both push-buttons.
4. Within these 5 sec., press the appropriate push-button on the radio control.
5. The relevant LED lights up on steady beam for 1 second and then goes OFF, indicating that storage was executed.
6. To add other radio controls, set the same ON - OFF combination used in point 1.

9.2 MEMORY STORAGE OF SLH RADIO CONTROLS

A maximum of 250 codes can be memory stored, split between OPEN A and OPEN B.

1. On the SLH radio control, simultaneously press and hold down push-buttons P1 and P2.
2. The radio control LED begins to flash.
3. Release both push-buttons.
4. Press the LOGIC (SW3) or SPEED (SW2) push-button, to memory store respectively total opening (OPEN A) or partial opening (OPEN B), and as you hold it down, also press the SET-UP (SW1) push-button. The relevant LED starts to flash slowly for 5 sec.
5. Release both push-buttons.
6. Within these 5 sec., while the radio control LED is still flashing, press and hold down the required push-button on the radio control (the radio control LED lights up on steady beam).
7. The LED on the board lights up on steady beam for 1 second and then goes OFF, indicating that storage was executed.
8. Release the radio control push-button.
9. Quickly press twice the memory stored radio control push-button.

The automated system performs one opening operation. Make sure that the automated system is free of any obstacle created by persons or things.

To add other radio controls, transfer the code of the memory-stored push-button of the radio control to the relevant push-button of the radio controls to be added, observing the following procedure.

- On the memory stored radio control, simultaneously press and hold down push-buttons P1 and P2.
- The radio control LED begins to flash.
- Release both push-buttons.
- Press the memory stored push-button and hold it down (the radio control LED lights up on steady beam).
- Bring the radio controls near, press and hold down the push-button of the radio control to be added, releasing it only after the double flash of the radio control LED, which indicates memory storage executed.
- Quickly press twice the push-button of the memory stored radio control.

The automated system performs one opening operation. Make sure that the automated system is free of any obstacle created by persons or things.

9.3 MEMORY STORAGE OF LC RADIO CONTROLS (for some markets only)

A maximum of 250 codes can be memory stored, split between OPEN A and OPEN B.

1. Use LC remote controls only with receiver module at 433 MHz.
2. Press the LOGIC (SW3) or SPEED (SW2) push-button, to memory store respectively total opening (OPEN A) or partial opening (OPEN B), and as you hold it down, also press the SETUP (SW1) push-button. The relevant LED starts to flash slowly for 5 sec.
3. Release both push-buttons. Within these 5 sec., press the appropriate push-button on the LC remote control.
4. The LED lights up on steady beam for 1 second, indicating memory storage executed, and then resumes flashing for another 5 sec., during which another radio control (point 4) can be memory stored.
5. When the 5 sec. have elapsed, the LED goes OFF indicating the end of the procedure.
6. To add other radio controls, repeat the operation at point 1.

9.3.1 REMOTE MEMORY STORAGE OF LC RADIO CONTROLS

Other radio controls can be remotely stored only with the LC radio controls, i.e. without using the LOGIC-SPEED-SETUP push-buttons, but using a previously stored radio control.

1. Get a radio control already stored on one of the 2 channels (OPEN A or OPEN B).
2. Press and hold down push-buttons P1 and P2 simultaneously until both the LEDs flash slowly for 5 sec.
3. Within 5 sec. press the push-button of the radio control that had been memory stored to enable learning on the selected channel.
4. The LED on the board relating to the channel being learned flashes for 5 sec., within which time the code of another radio control must be transmitted.
5. The LED lights up on steady beam for 2 seconds, indicating memory storage executed, and then resumes flashing for 5 sec., during which other radio controls can be memory stored, and then goes OFF.

9.4 RADIO CONTROLS DELETION PROCEDURE

To delete ALL the input radio control codes, press push-button LOGIC (SW3) or SPEED (SW2) and, while holding it down, also press push-button SETUP (SW1) for 10 sec.

1. The LED relating to the pressed push-button flashes for the first 5 sec., and then flashes more quickly for the next 5 sec.
2. Both LEDs light up on steady beam for 2 sec and then go OFF (deletion completed).
3. Release both push-buttons.



This operation is NOT reversible. All codes of radio controls stored as OPEN A and OPEN B will be deleted.

10 CONNECTION OF BUFFER BATTERIES (OPTIONAL)

The buffer battery kits will activate the automated system also in the event of a power cut. The housing of the batteries is specified in different configurations according to the type of batteries used.

For correct positioning, observe the following instructions, referring to your type of battery.

 **The batteries come into operation when a mains power cut occurs.**

10.1 BATTERY KIT

The buffer battery kit was built for insertion inside the control board support.

This support (Fig.11 ref.①) was pre-moulded to permit the battery housing to be opened.

1. Remove the board support material covering the battery housing, cutting the material connections along the perimeter.

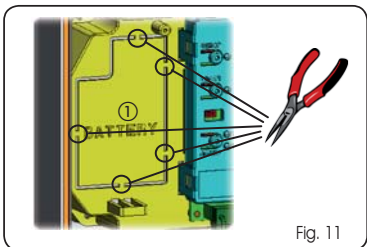

Fig. 11

2. Insert the battery in the housing you have just created, and secure it on the anchoring supports (Fig.12).

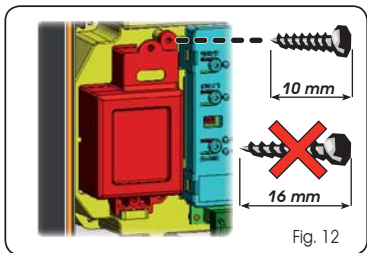

Fig. 12

3. To correctly fasten and connect the kit to the control unit, consult the instructions enclosed with the battery kit.

11 AUTOMATED SYSTEM TEST

When you have finished programming, check if the system is operating correctly. In particular, check if the safety devices are operating correctly.

12 LOGIC TABLES
Tab. 5

LOGIC "A" STATUS OF AUTOMATED SYSTEM	PULSES						
	OPEN A	OPEN B	STOP	FSW-OP	FSW-CL	FSW-OP/CL	FSW-OPEN
CLOSED	opens leaves and closes after pause time	opens leaf 1 and closes after pause time	no effect (opening inhibited)	no effect (opening inhibited)	no effect	no effect (opening inhibited)	opens leaves and closes after pause time
OPENING	no effect	no effect	stops operation	reverses immediately at closing	no effect	stops and continues to open at disengagement	no effect (1)
OPEN IN PAUSE	recharge the pause time	recharge the pause time	stops operation	no effect	recharges pause time (closing inhibited)	recharges pause time (closing inhibited)	recharges pause time (closing inhibited) (1)
CLOSING	reverses immediately at opening	reverses immediately at opening	stops operation	no effect	reverses immediately at opening	stops and, at disengagement, reverses at opening	reverses immediately at opening
STOPPED	closes	closes	no effect (opening and closing inhibited)	no effect (opening inhibited)	no effect (closing inhibited)	no effect (opening and closing inhibited)	opens leaves

Tab. 6

LOGIC "Ep" STATUS OF AUTOMATED SYSTEM	PULSES						
	OPEN A	OPEN B	STOP	FSW-OP	FSW-CL	FSW-OP/CL	FSW-OPEN
CLOSED	opens leaves	opens leaf 1	no effect (opening inhibited)	no effect (opening inhibited)	no effect	no effect (opening inhibited)	opens leaves
OPENING	stops operation (1)	stops operation	stops operation	reverses immediately at closing	no effect	stops and continues to open at disengagement	no effect (1)
OPEN	closes	closes	no effect (closing inhibited)	no effect	no effect (closing inhibited)	no effect (closing inhibited)	no effect (1)
CLOSING	stops operation	stops operation	stops operation	no effect	reverses immediately at opening	stops and, at disengagement, reverses at opening	reverses immediately at opening
STOPPED	After OPEN: Restarts moving in reverse direction After STOP: Re-closes the leaf/ves immediately (1)	stops operation	no effect (opening and closing inhibited)	no effect (opening inhibited)	no effect (closing inhibited)	no effect (opening and closing inhibited)	opens leaves

(1) If the cycle began with OPEN-B (partial opening), an OPEN-A pulse will activate both leaves to open.