

**TIR 60-120**

D811162 04-04-02 Vers. 04

**AUTOMATION FOR  
SPRING OVERHEAD  
DOORS**



Thank you for buying this product, our company is sure that you will be more than satisfied with the product's performance. The product is supplied with a "Warnings" leaflet and an "Instruction booklet". These should both be read carefully as they provide important information about safety, installation, operation and maintenance. This product complies with the recognised technical standards and safety regulations. We declare that this product is in conformity with the following European Directives: 89/336/EEC and 73/23/EEC (and subsequent amendments).

## 1) GENERAL SAFETY

**WARNING! An incorrect installation or improper use of the product can cause damage to persons, animals or things.**

- The "Warnings" leaflet and "Instruction booklet" supplied with this product should be read carefully as they provide important information about safety, installation, use and maintenance.
- Scrap packing materials (plastic, cardboard, polystyrene etc) according to the provisions set out by current standards. Keep nylon or polystyrene bags out of children's reach.
- Keep the instructions together with the technical brochure for future reference.
- This product was exclusively designed and manufactured for the use specified in the present documentation. Any other use not specified in this documentation could damage the product and be dangerous.
- The Company declines all responsibility for any consequences resulting from improper use of the product, or use which is different from that expected and specified in the present documentation.
- Do not install the product in explosive atmosphere.
- The construction components of this product must comply with the following European Directives: 89/336/CEE, 73/23/EEC and subsequent amendments. As for all non EEC countries, the abovementioned standards as well as the current national standards should be respected in order to achieve a good safety level.
- The Company declines all responsibility for any consequences resulting from failure to observe Good Technical Practice when constructing closing structures (door, gates etc.), as well as from any deformation which might occur during use.
- The installation must comply with the provisions set out by the following European Directives: 89/336/CEE, 73/23/EEC and subsequent amendments.
- Disconnect the electrical power supply before carrying out any work on the installation. Also disconnect any buffer batteries, if fitted.
- Fit an omnipolar or magnetothermal switch on the mains power supply, having a contact opening distance equal to or greater than 3mm.
- Check that a differential switch with a 0.03A threshold is fitted just before the power supply mains.
- Check that earthing is carried out correctly: connect all metal parts for closure (doors, gates etc.) and all system components provided with an earth terminal.
- Fit all the safety devices (photocells, electric edges etc.) which are needed to protect the area from any danger caused by squashing, conveying and shearing.
- Position at least one luminous signal indication device (blinker) where it can be easily seen, and fix a Warning sign to the structure.
- The Company declines all responsibility with respect to the automation safety and correct operation when other manufacturers' components are used.
- Only use original parts for any maintenance or repair operation.
- Do not modify the automation components, unless explicitly authorised by the company.
- Instruct the product user about the control systems provided and the manual opening operation in case of emergency.
- Do not allow persons or children to remain in the automation operation area.
- Keep radio control or other control devices out of children's reach, in order to avoid unintentional automation activation.
- The user must avoid any attempt to carry out work or repair on the automation system, and always request the assistance of qualified personnel.
- Anything which is not expressly provided for in the present instructions, is not allowed.

## 2) TECHNICAL DETAILS

Power supply	:230V~ +/-10%, 50/60Hz Single phase (*)
Motor voltage	:24V=
Motor power	:TIR60 - 180W / TIR120 - 260W
Absorption	:TIR60 - 0.7A / TIR 120 - 0.9A
Lubrication	:Permanent grease
Traction and thrust	:TIR60 600N : TIR120 1200N
Usable stroke	:2.55m (with extension Mod.PT13.5m)
Average speed (m/min)	:TIR-60 5 approx :TIR-120 6.5 (approx.)

Reaction to the collision when closing	: Amperostop (Stop and reverse)
Manoeuvres in 24h	:TIR60 100 : TIR120 200
Limit switches	:Electric and adjustable
Courtesy light	:Lamp 230V~ 25W max., E14
Working temperature	:-15°C +60°C
Protection degree	:IP X0
Total weight	:12 kg
Dimensions	:See fig. 1

(\*) Available in all network voltages.

## 3) GENERAL INFORMATION

Suitable for motorising sectional doors (fig. 2), spring overhead doors with total reentrance (fig. 3) and overhead doors with counterweights by means of a special pulling arm (fig. 4). The maximum height of the overhead door must not exceed 2.5 meters (3.5 meters with extension).

The installation is carried out easily, it allows a fast assembly without any change to the door. The closing lock is maintained by the irreversible motor reducer. This product was designed in order to motorise the above mentioned types of doors. Any other use will be considered contrary to the use foreseen by the manufacturer which, therefore, cannot be considered responsible for any caused damage to things, people, animals.

## 4) INSTALLATION OF THE AUTOMATION

Preliminary controls

Check the balance of the door.

Check the sliding of the door for all its travel.

If the door is not of new installation, check the wear state of all its component parts. Fix or replace the faulty or worn parts.

The reliability and safety of the automation is directly influenced by the condition of the structure of the door.

## 5) ASSEMBLY

Once removed the packing, the door opener presents itself as in fig. 5. We would like to remind you to dispose of all the components of the packing separating the different types of material (cardboard, polystyrene, PVC etc.) according to what foreseen by the national regulations in force.

- Remove the existing locking bolt from the door cremone bolt.
- Place the joint "G" as in fig. 6.
- Place the half track as in fig. 7 and lower it to the face putting the chain into tension and obtaining in this way the whole track.
- Place the joint divided into two between the two semi-tracks as in fig. 8.
- Block the joint by tightening the special supplied screws as in fig. 9. The door opener is therefore ready for the installation.
- Mark the centre line of the door and fix the pin joint of the track to the door frame as in fig. 10. If the height of the ceiling of the room allows it, it is possible to assemble the pin joint higher fixing it to the masonry headsill with wedges.
- With the aid of a support as a ladder, lift the motorised head until levelling the track as in fig. 11.
- Fasten the two supporting brackets to the ceiling as in fig. 12. Check everything again and fasten the two supporting brackets onto the base plate of the motor reducer.
- Unlock the pulling carriage (fig. 13) by pulling the cord and bringing the pulling arm to the door frame. Fix the pulling arm to the door frame as in fig.14 using the supplied screws.

## 6) ELECTRIC SYSTEM PREPARATION (fig.15)

- Type approved omnipolar switch with 3 mm min. contact opening, provided with overload and short-circuit protection, used to break the automation connection from the mains. If not present, provide the automation with a type approved differential switch with adequate capacity and a 0.03 A threshold.

Qr) Control unit with built-in receiver

M) Actuator

Ft-Fr) Pair of photocells (transmitter) (receivers)

T) 1-2-4 channel transmitter

Prepare the arrival of the connections of the attachments, of the safety and control devices to the motor unit keeping the connections to the line voltage well separated from the connections of the attachments in low tension. Proceed to their connection as indicated in the electric diagram (fig. 16). Once finished, if the radio receiver board is inserted in the control unit, the equipment is ready to work with remote control. If a remote control is not used, the actioning is carried out by means of a start push-button connected as indicated in the general electric diagram (fig. 16).

## 7) CONTROL UNIT STIR-LF1 (fig. 16)

Characteristics

Pre-alarm about 3 s

Reverse pause about 3 s

Service light switching on time 90 s  
Adjustable TCA time from 15 to 100 s  
Slowing-down in opening and closing  
Amperostop regulation in closing and opening  
Attachments outputs 17Vav max. 8.5VA  
Flashing light connection 230V max. 40W

## 8) TERMINAL BOARD CONNECTIONS (fig. 16)

### JP1

1-2 Photocells and attachments power supply 17V~ max. 8.5 VA

**JP2** Receiver board connector

### JP3

1-2 Courtesy light connection 230V~ max. 25W

3-4 Transformer power supply

5-6 Single phase power supply 230V~ ± 10%, 50-60Hz (5=N 6=L)

7-8 Flashing light connection 230V~ max. 40W

**JP4** Predisposition II° radio channel output CH2

### JP5

1 Transformer connection 25V

2-3 Motor connection

TIR 60: 2 Brown - 3 Gray

TIR 120: 2 Yellow - 3 Blue

4 Transformer connection 15V or 20V

5 Transformer connection 0V

### JP6

1-2 Antenna connection (1 signal - 2 sheath)

**JP8** Connector for stopping limit switch

**JP9** Connector for slowing down microswitches

### JP10

1-2 Photocells input, sensitive cushion (N.C.). If not used, leave jumped.

3-4 Locking push-button (N.C.). If not used, leave jumped.

5-6 Open-close push-button or key selector (N.O.)

## 9) TRIMMER REGULATION (fig. 16)

**P1 - TCA** - Regulates the pause time with open gate after which the door closes.

**P2 - AMPOP** - Regulates the intervention threshold of the anticrushing during the opening phase.

**P3 - AMPCLS** - Regulates the intervention threshold of the anticrushing during the closing phase.



**WARNING: Check that the impact force value measured at the points established by the EN 12445 standard is lower than that specified in the EN 12453 standard.**

## 10) JUMPER SETTING (fig. 16)

### DF1 - PREALL

ON - Inserts pre-alarm (Disconnect power at every change).

OFF - Switches off pre-alarm (Disconnect power at every change).

### DF2 - TCA

OFF - Inserts the automatic closing.

ON - Switches off the automatic closing.

## 11) TEST PUSH-BUTTON (fig. 16)

A start push-button is foreseen as a test on the board for controlling the opening and closing manoeuvre.

## 12) CHAIN TIGHTENER REGULATION

The automation is supplied already calibrated and tested. If it is necessary to adjust the tension of the chain proceed as indicated in fig. 17.

**ATTENTION:** The compression spring must never be compressed completely. Check carefully that the spring does not go into total compression during the functioning.

## 13) LIMIT SWITCH REGULATION

The operator disposes of a unit for limit switch regulation which is supplied already regulated for the maximum available travel. The limit switch unit is equipped with 2 microswitches for every direction: the first intercepted activates the slowing down, the second intercepted stops the operator.

**ATTENTION:** before carrying out any regulation operation, disconnect the power from the system. Every time the power is disconnected from the system, the electronics resets. When power is given to the system, the first start always carries out the opening manoeuvre. To regulate the opening and closing microswitches, proceed as follows:

- If the pulling carriage is in the position of manual unlocking, bring it to the chain coupling moving the door manually until coupling it up and give power supply to the system.
- Give START: the first control always carries out the opening manoeuvre. Give START to stop the door when it is in the position of total opening.

To regulate the limit of the travel, lift the holding spring from the gear teeth of the cam with a screwdriver (fig. 18), rotate the opening cam in the direction of the opening microswitches "OPEN", until hearing the click of the first and second limit switch. Lower the spring until fitting a tooth of the cam.

- Feed the system and give START to carry out the closing manoeuvre. Give Start when the door is completely closed. Lift the holding spring from the gear teeth of the cam with a screwdriver (fig. 19), rotate the closing cam in the direction of the closing microswitches "CLOSE", until hearing the click of both limit switches. Lower the spring until fitting a tooth of the cam.
- Give power and check the slowing down and stopping in both positions. Check that the stopping during opening and closing is carried out without excessive traction or compression of the system.
- Repeat the complete opening and closing manoeuvre a few times in order to control if the limit microswitches intervene correctly. Regulate the position of the cams if necessary.
- The holding spring must always be fitted in the gear teeth of the cams in order to maintain their position.
- Reassemble the cowling of the operator.

## 14) SLOWING DOWN SPEED AND TORQUE (fig.20)

N.B. If the thrust, in the final opening and closing phase does not allow to obtain the complete desired manoeuvre, it is possible to increase the force of the motor reducer by moving the connection of the transformer from terminal 3 to terminal 4 as in fig. 20.

## 15) EMERGENCY MANOEUVRE

If there is no power or because of a breakdown of the system, to carry out the manoeuvre manually, pull the cord connected to the carriage as in fig. 21. For garages without secondary exit it is compulsory to assemble an unlocking device from outside with key ( Mod. SM1-fig.22 or Mod. SET/S-fig23).

## 16) CONTROL OF THE AUTOMATION

Before making the automation definitely operative, carefully check the following:

- Check the correct functioning of all safety devices (limit microswitches, photocells, sensitive cushions etc.).
- Check that the thrust (anticrushing) of the door is within the limits foreseen by the regulations in force.
- Check that the chain tightener spring is not compressed completely during the manoeuvre.
- Check the manual opening control.
- Check the opening and closing operation with the applied control devices.
- Check the electronic logic of normal and personalised functioning.

## 17) USE OF THE AUTOMATION

As the automation can be controlled at a distance by means of remote control or start push-button, and therefore not at sight, it is indispensable to control frequently the perfect efficiency of all safety devices. For any functioning anomaly, intervene rapidly even with the help of qualified personnel. We recommend to keep children at a suitable distance from the range of action of the automation.

## 18) CONTROL

The use of the automation allows the opening and closing of the door in a motorised way. The control can be of different types (manual, with remote control, access control with magnetic badge etc.) according to the necessity and the characteristics of the installation. For the various control systems, see the relative instructions.

The users of the automation must be instructed about its control and use.

## 19) MAINTENANCE

For any maintenance, disconnect the system from the power supply.

- Check periodically (twice a year) the tightening of the chain.
- Carry out occasionally the cleaning of the photocells optics if installed.
- Have the correct regulation of the electronic clutch controlled by qualified personnel (installer).
- For any functioning anomaly, not solved, disconnect the system from the power supply and request the intervention of qualified personnel (installer). During the out of order period, activate the manual unlocking in order to allow the manual opening and closing.

## 20) NOISE

The environmental noise produced by the gear-motor in normal operation conditions is constant and does not exceed 70 dB (A).

## 21) ACCESSORIES

- SM1** External unlocking to assemble to the existing cremone bolt of the overhead door (fig. 22).
- SET/S** External unlocking with receding handle for sectional doors max. 50mm (fig. 23).
- PT1** 1 m extension for garage doors up to 3.50m (fig. 24).
- APT** Extension and bracket attachments for spaced or close to ceiling assembly (fig. 25).
- ST** Automatic unlocking of bolts for spring overhead doors. Applied to the control arm, it unhooks the side bolts of the door automatically (fig. 26).

## 22) SCRAPPING

**Warning! This operation should only be carried out by qualified personnel.** Materials must be disposed of in conformity with the current regulations. In case of scrapping, the automation devices do not entail any particular risks or danger. In case of materials to be recycled, these should be sorted out by type (electrical components, copper, aluminium, plastic etc.).

## 23) DISMANTLING

**Warning! This operation should only be carried out by qualified personnel.** When the automation system is disassembled to be reassembled on another site, proceed as follows:

- Disconnect the power supply and the entire external electrical installation.
- In the case where some of the components cannot be removed or are damaged, they must be replaced.

**The descriptions and illustrations contained in the present manual are not binding. The Company reserves the right to make any alterations deemed appropriate for the technical, manufacturing and commercial improvement of the product, while leaving the essential product features unchanged, at any time and without undertaking to update the present publication.**

# TIR 60-120

Fig. 1

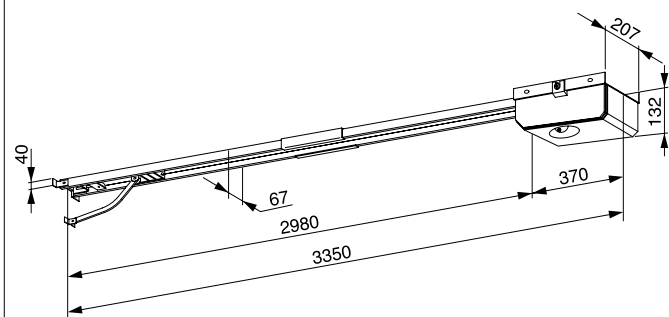

Fig. 2

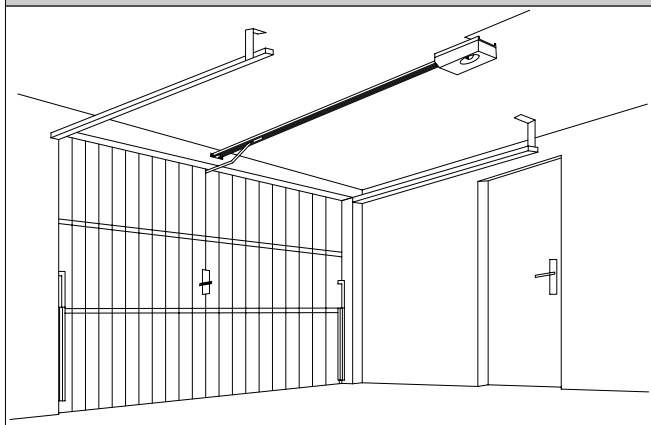

Fig. 3

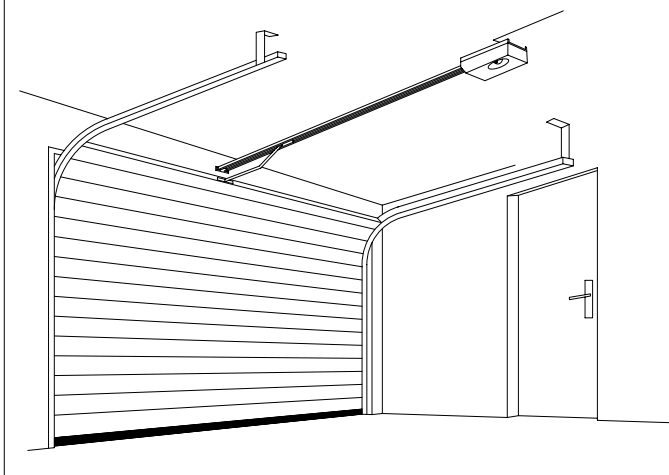

Fig. 4

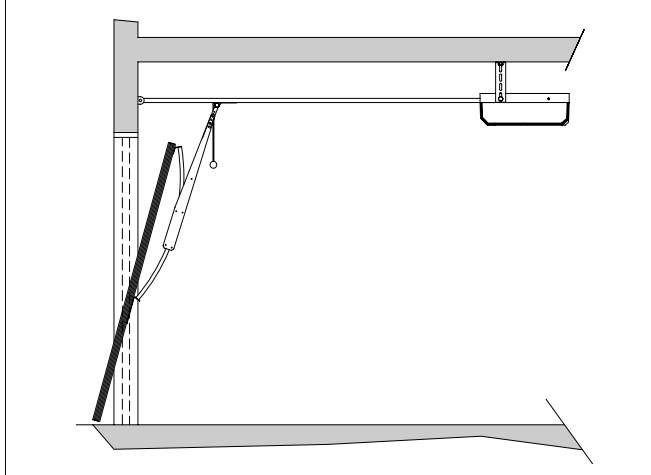

Fig. 5

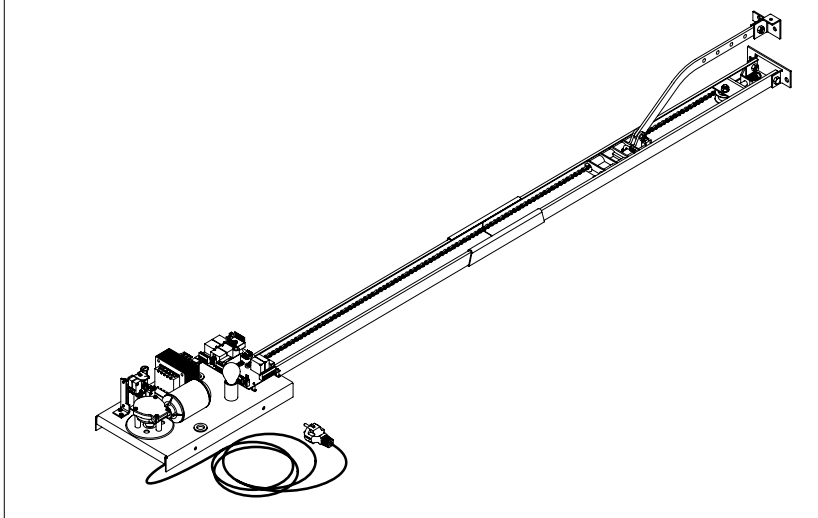

Fig. 7

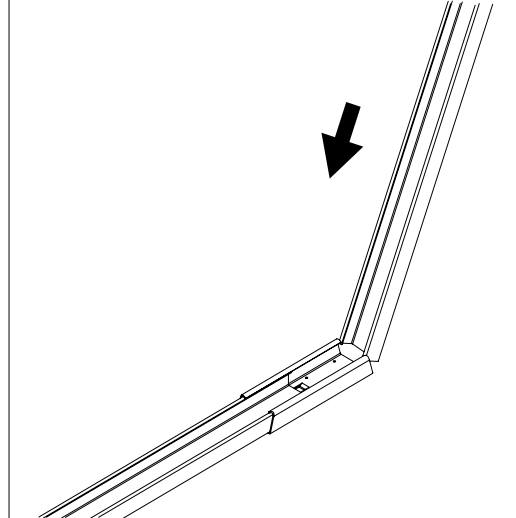

Fig. 6

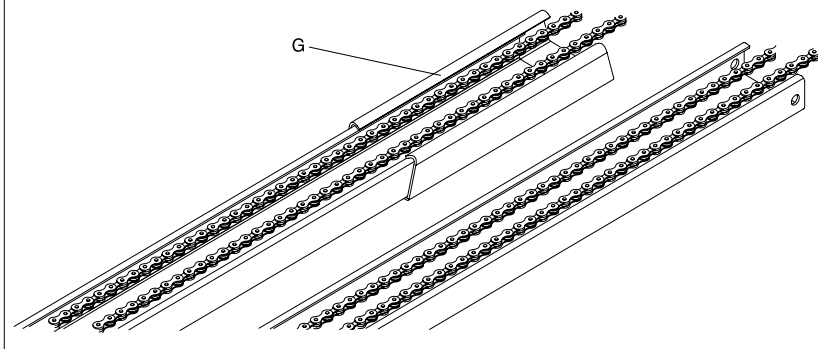
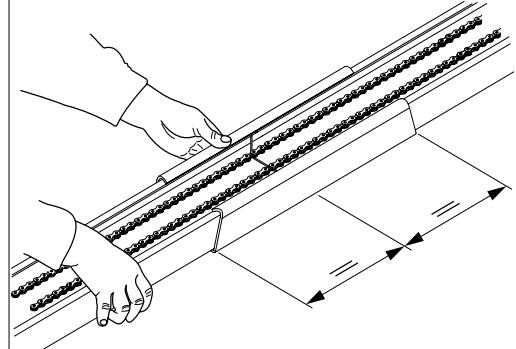

Fig. 8



D81162\_04

Fig. 9

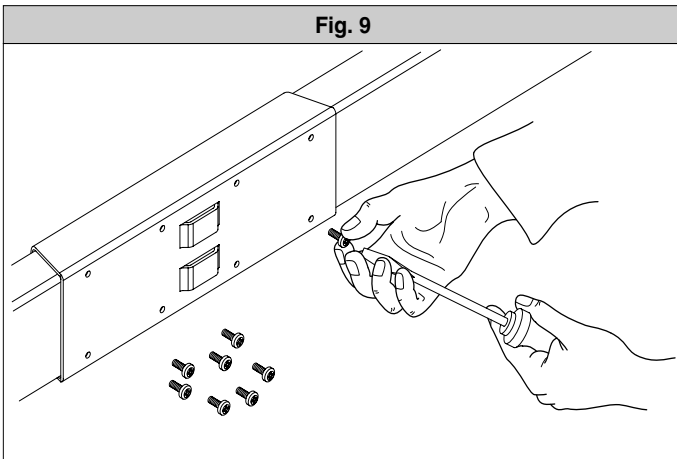

Fig. 10

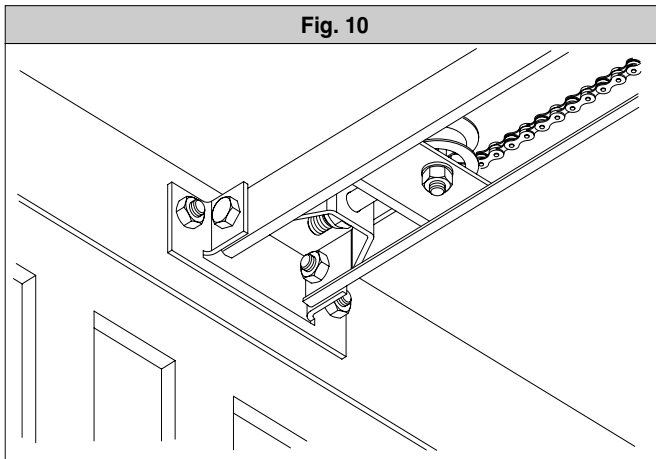

Fig. 11

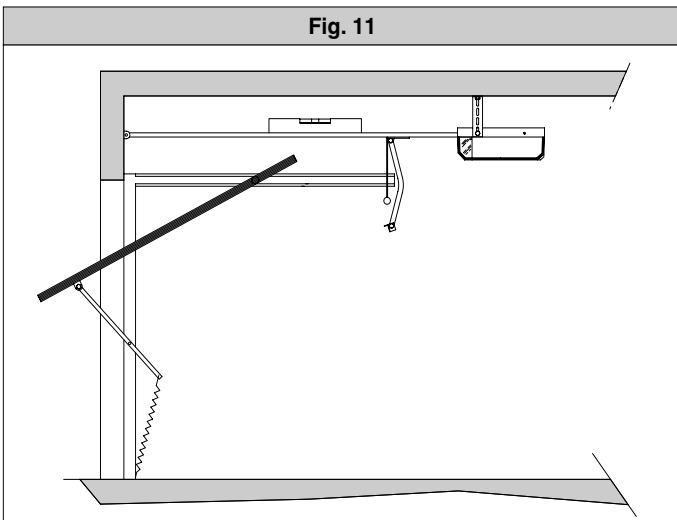

Fig. 12

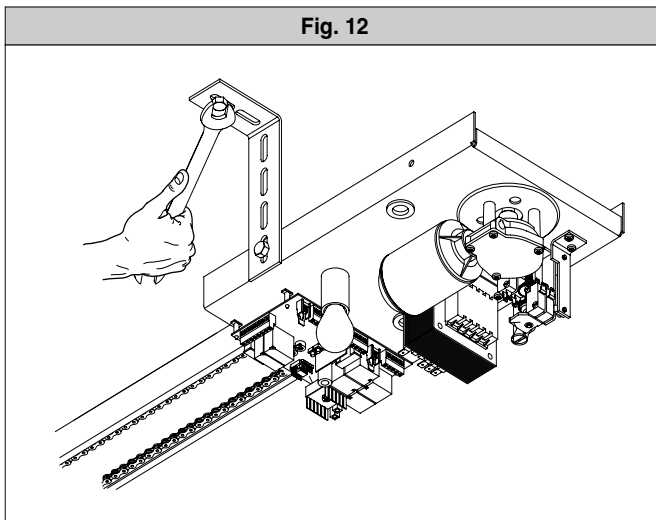

Fig. 13

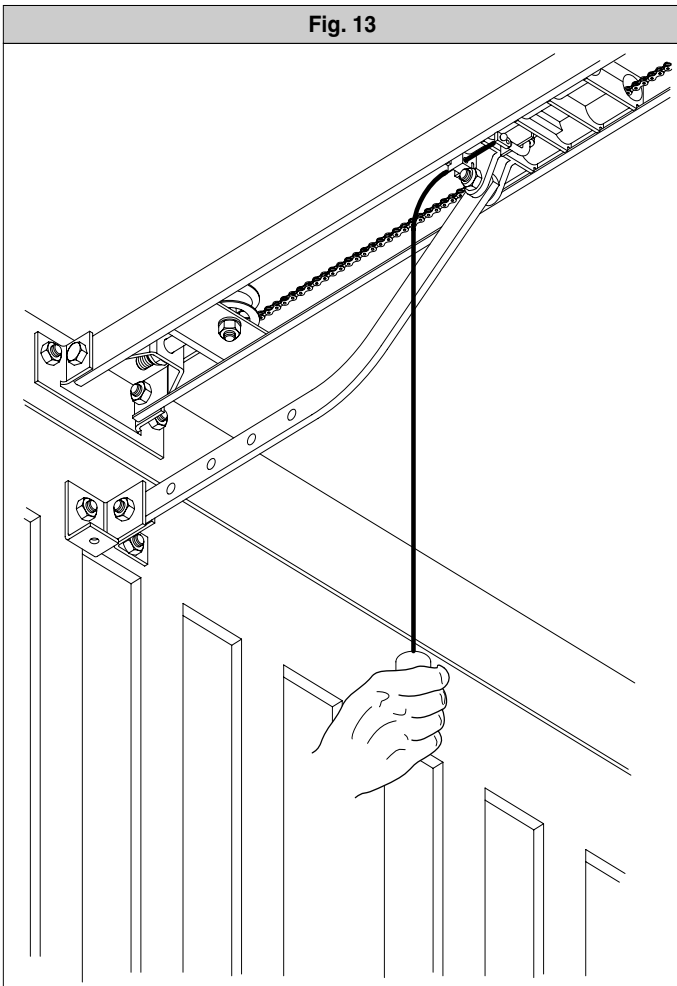

Fig. 14

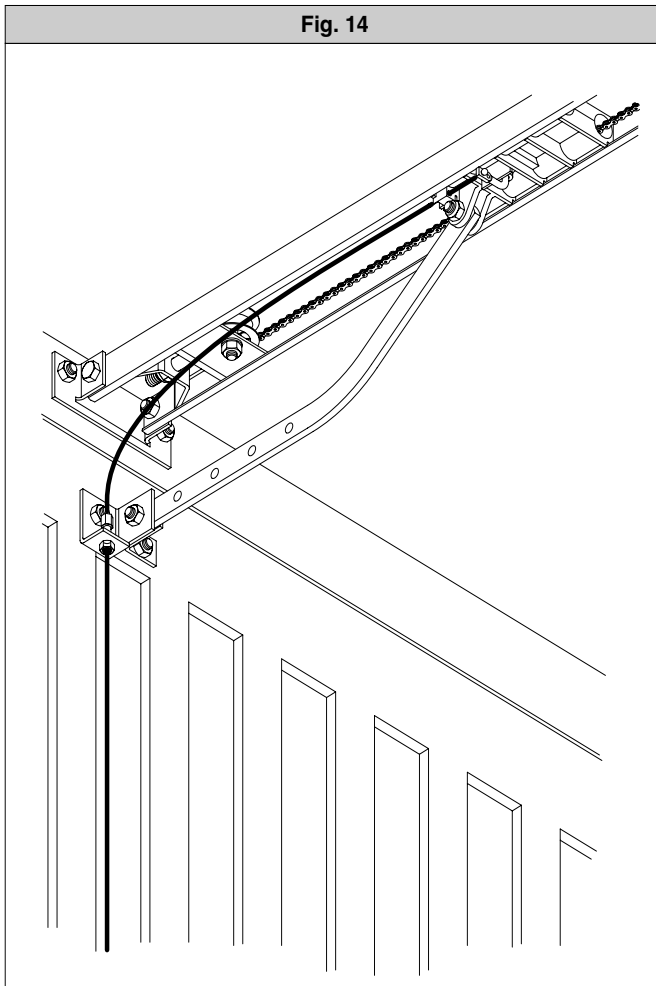

Fig. 15

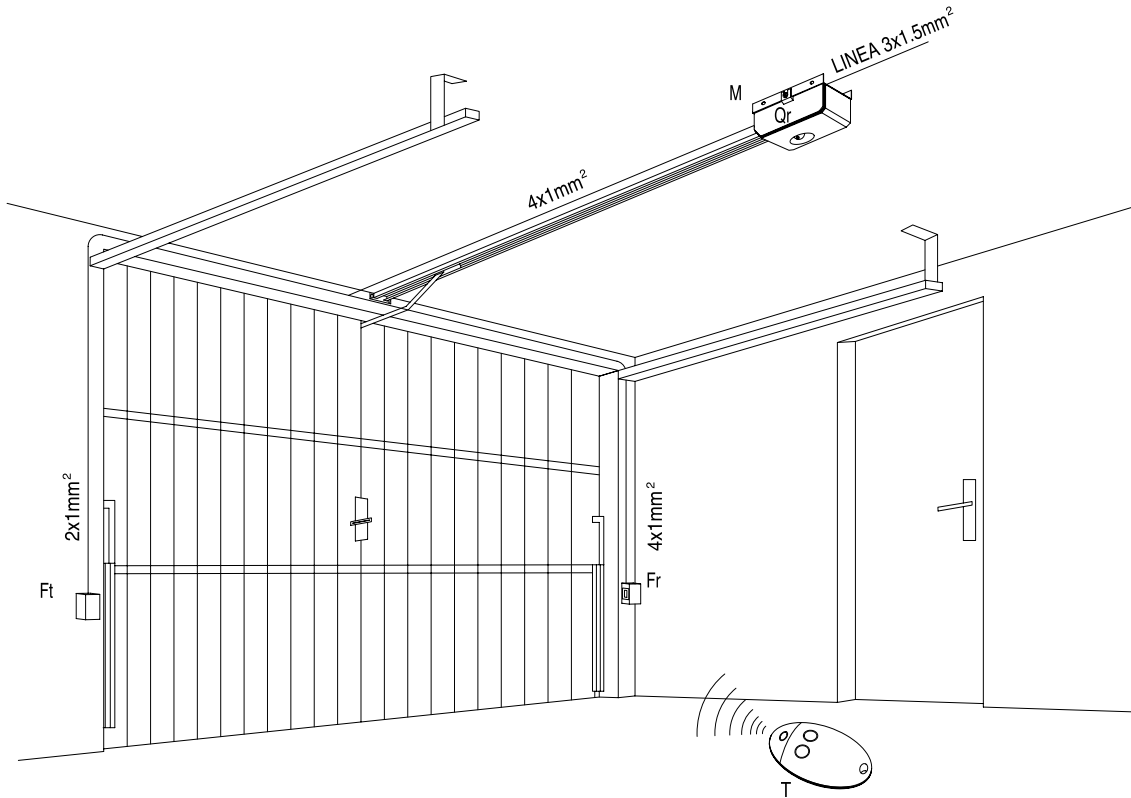
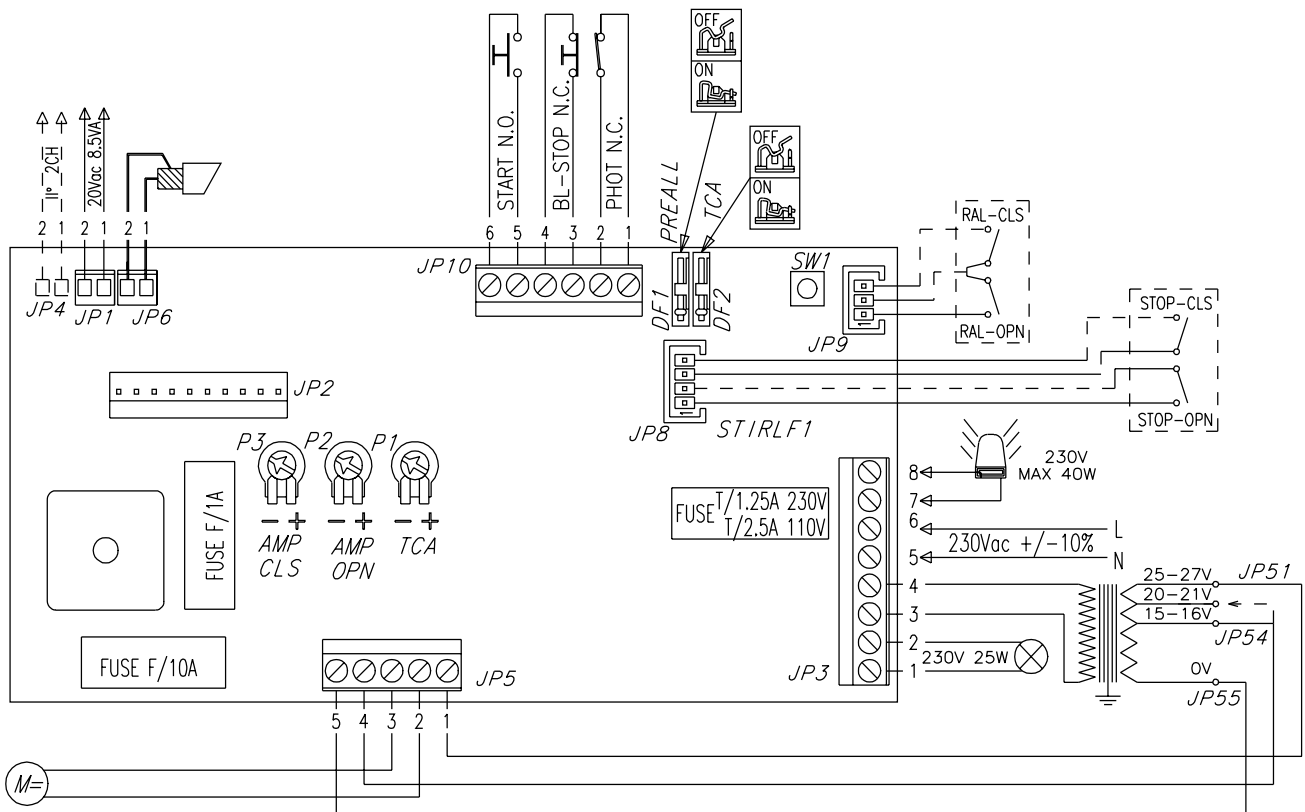

Fig. 16



- JP5** TIR 60: 2 Marrone/Brown/Brun/Braun/Marron/Castanho  
 3 Grigio/Gery/Gris/Grau/Gris/Cinza  
 TIR 120: 2 Jaune/Jellow/Jaune/Gelb/Amarillo/Amarelo  
 3 Blu/Blue/Bleue/Blau/Azul/Azul Escuro

D81162\_04

Fig. 17

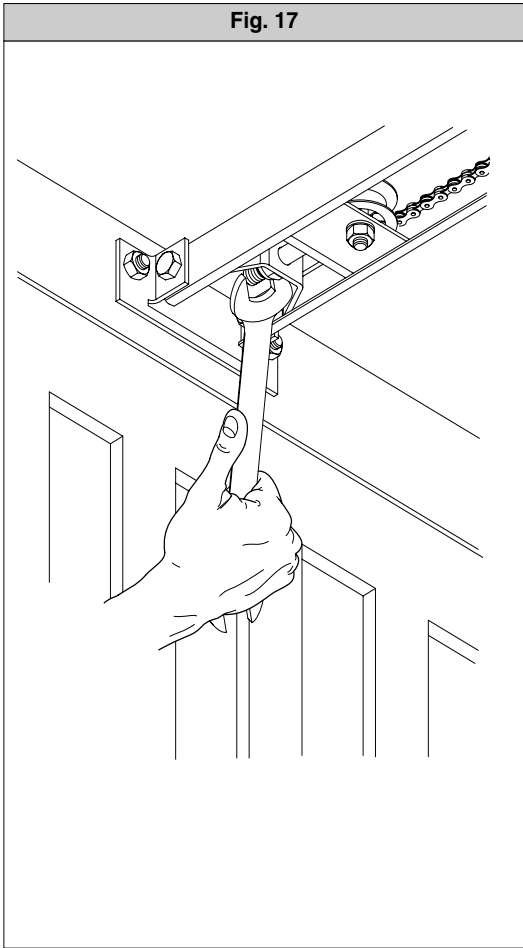

Fig. 18

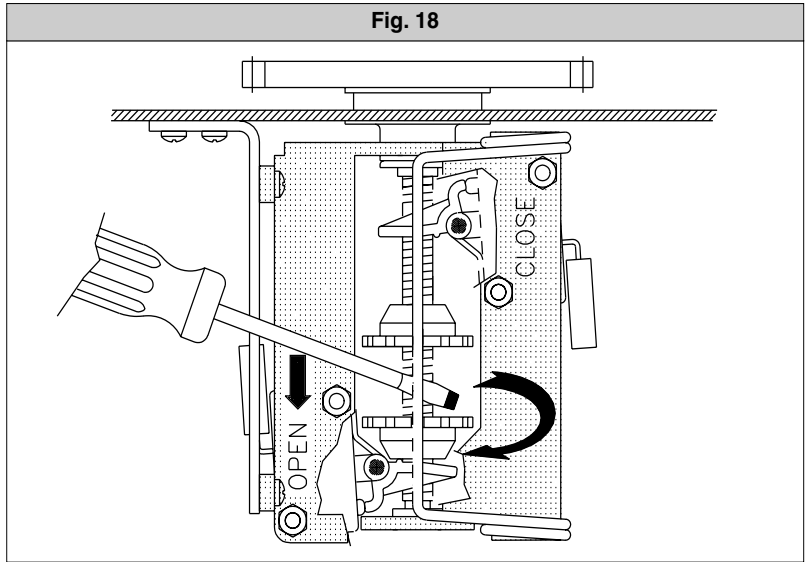

Fig. 19

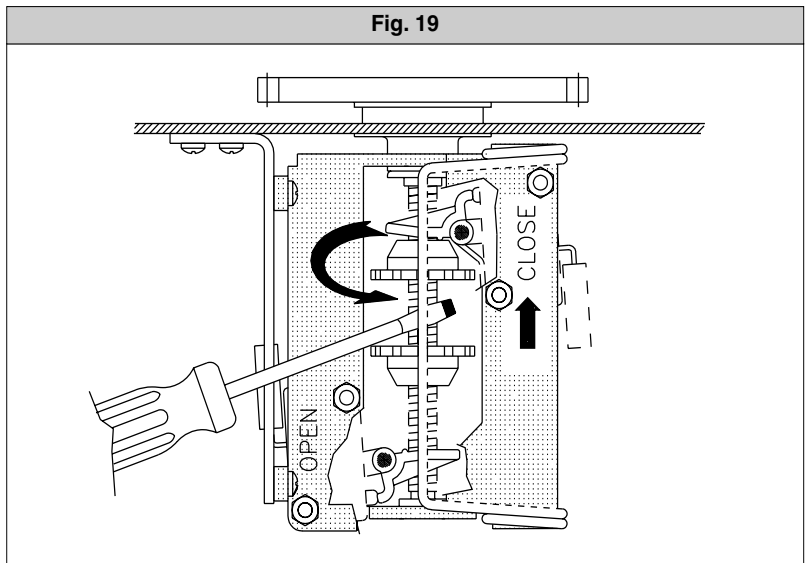

Fig. 20

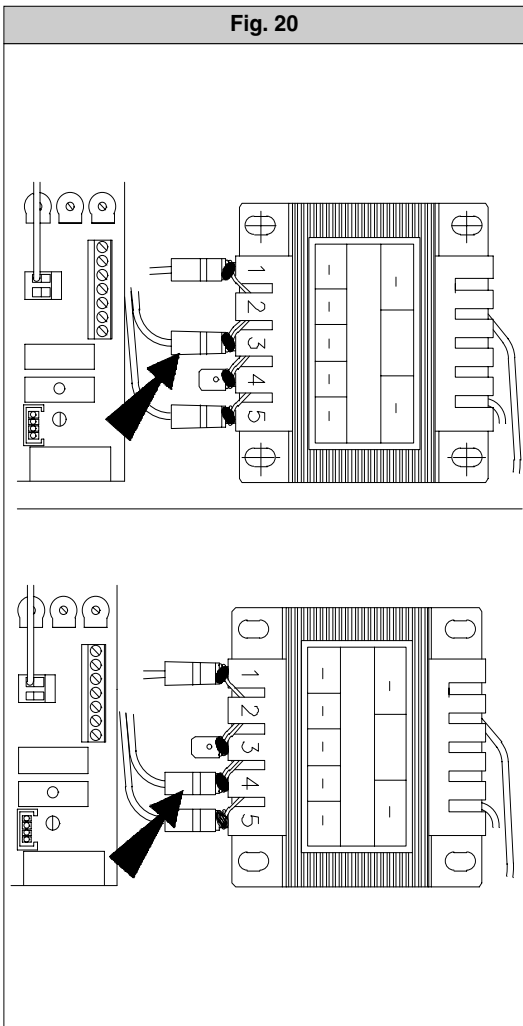

Fig. 21

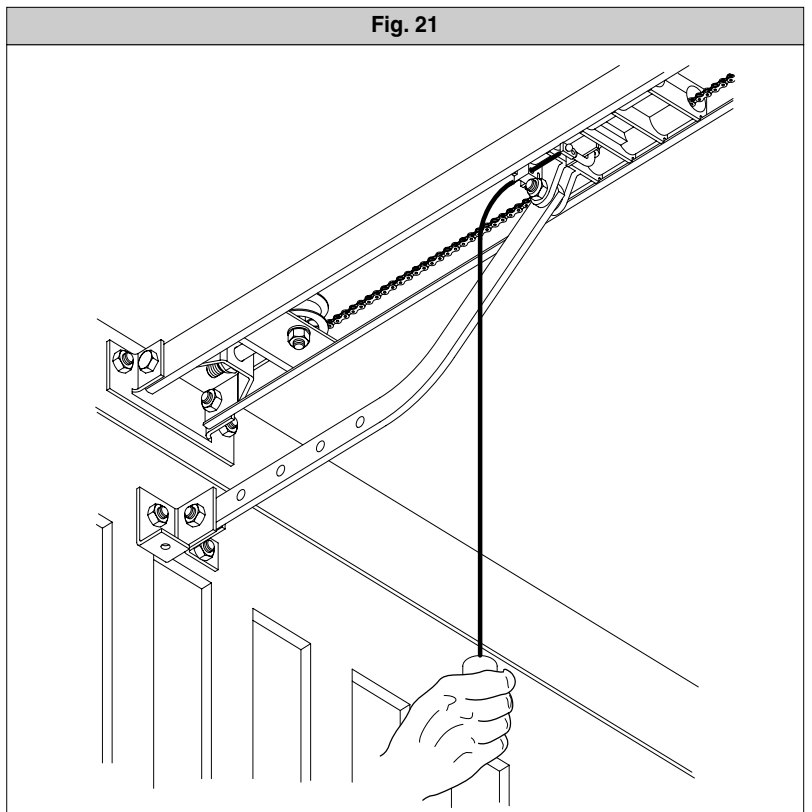



Fig. 22

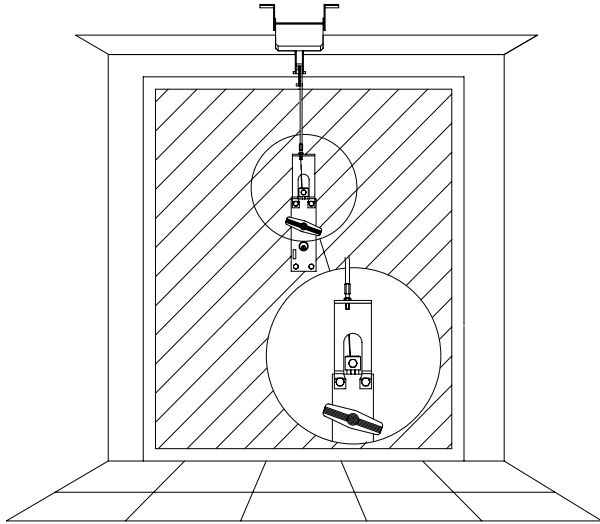

Fig. 23

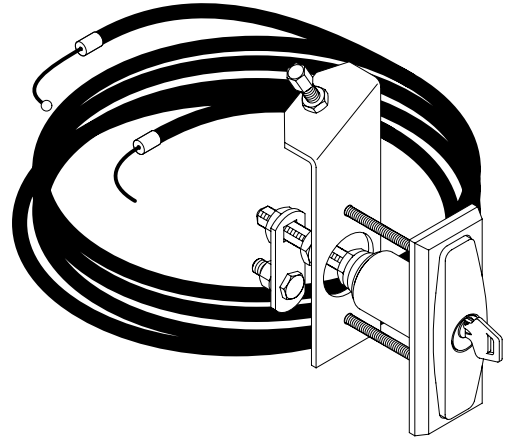

Fig. 24

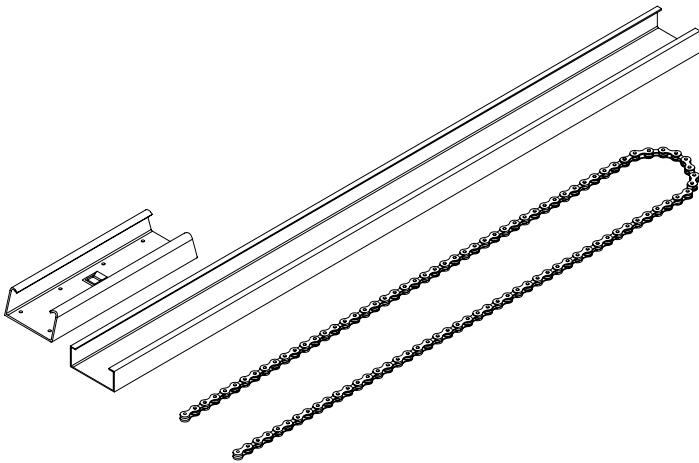

Fig. 25

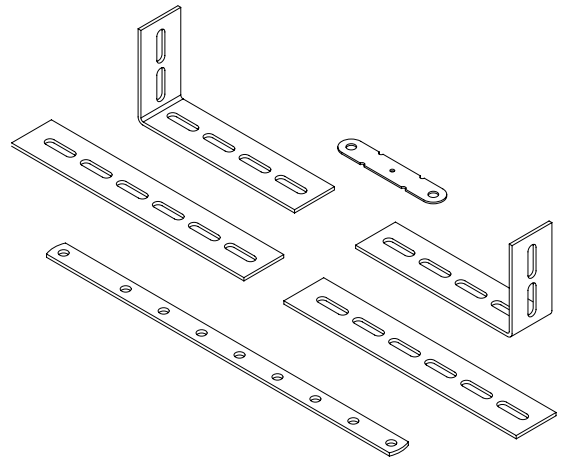
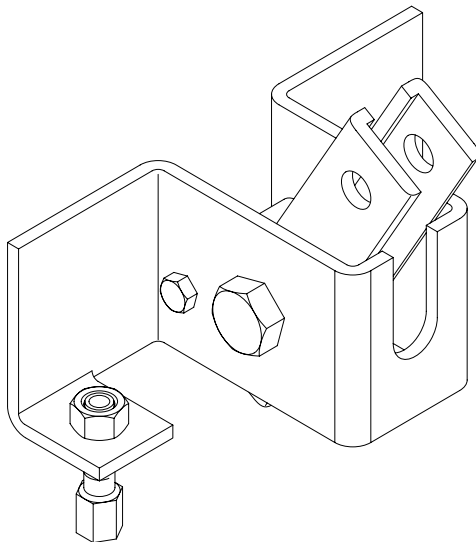

Fig. 26



D81162\_04