

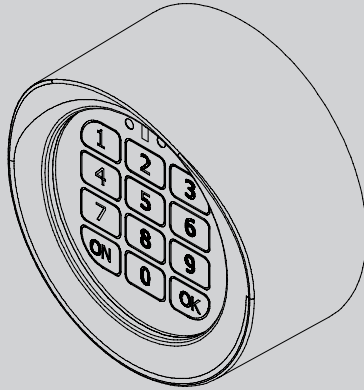

D811625 00100_01 03-09-08

PROGRAMMABLE DIGITAL PUSHBUTTON PANEL

T-BOX X



INSTALLATION MANUAL



AZIENDA CON SISTEMA DI GESTIONE INTEGRATO CERTIFICATO DA DNV = **UNI EN ISO 9001:2000** = UNI EN ISO 14001:2004

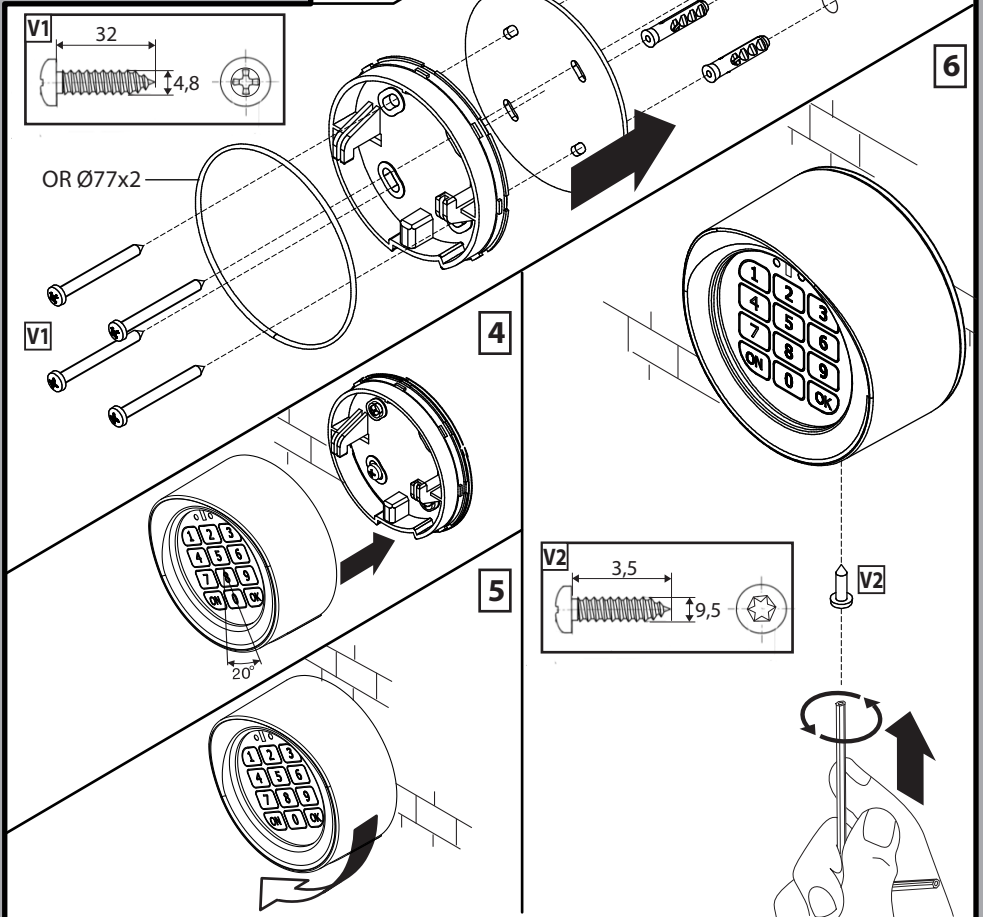
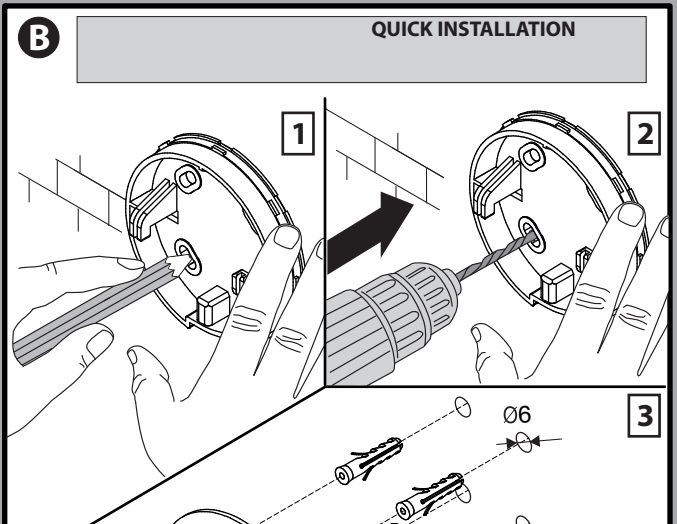
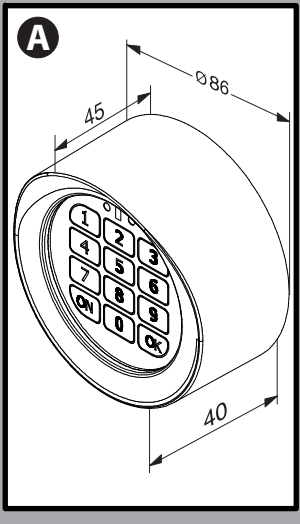

C**MEMORIZING ON CONTROL UNIT**

D811625 00100_01

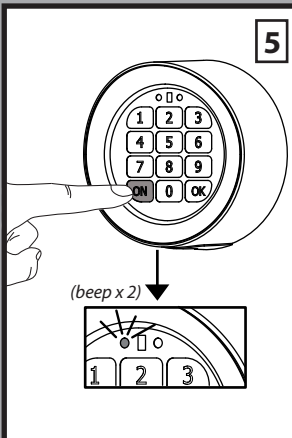
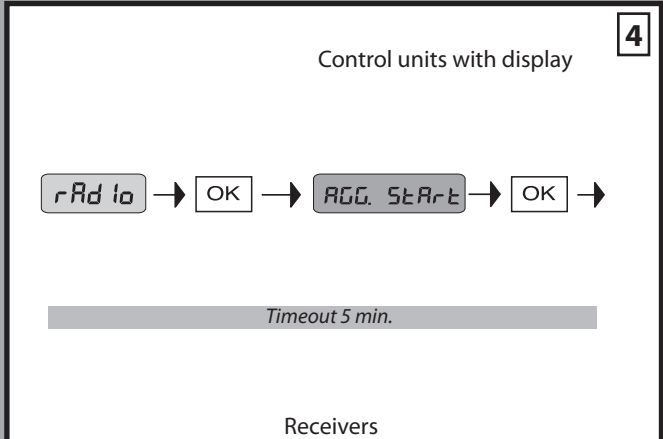
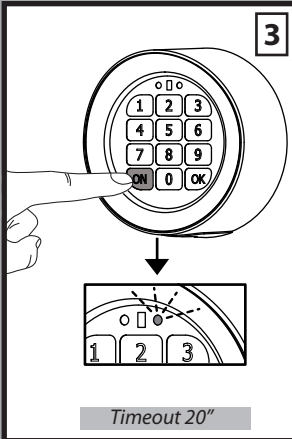
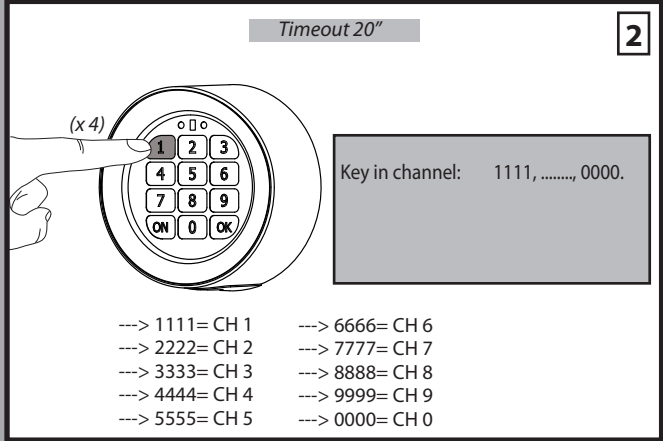
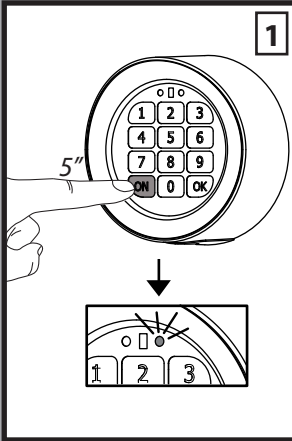

Follow the instructions relating to the receiver/control unit used!

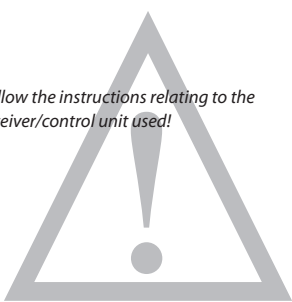
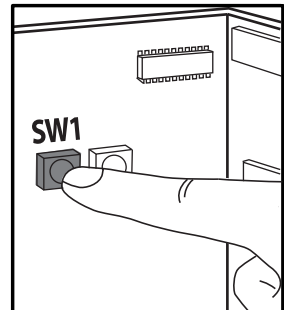
D

CANCEL ALL CODES

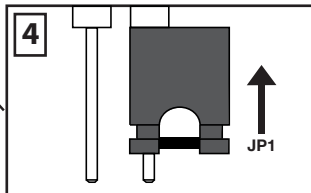
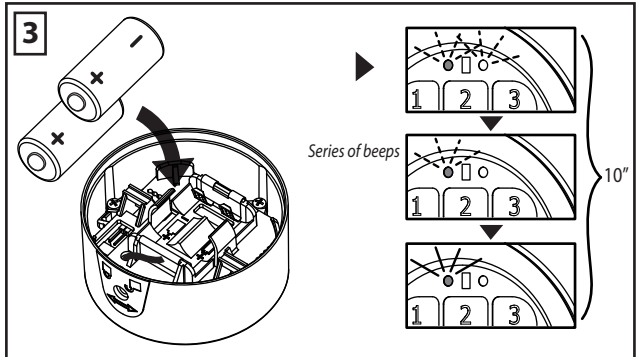
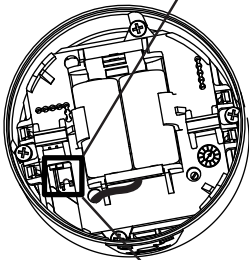
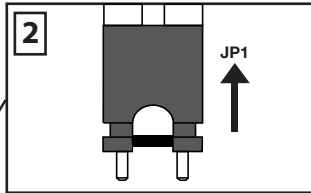
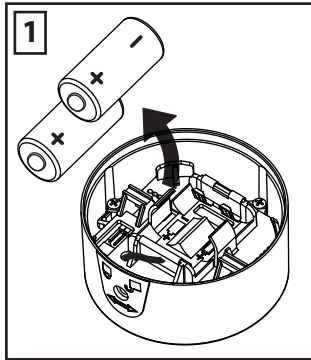

LED state = unlit.

5 MEMORY CANCELLED

GENERAL OUTLINE

Thank you for buying this product, our Company is sure that you will be more than satisfied with the product's performance. The product is supplied with a "Warnings" leaflet and an "Instruction booklet". These should both be read carefully as they provide important information about safety, installation, operation and maintenance. This product complies with the recognised technical standards and safety regulations. We declare that this product is in conformity with the following European Directives: 99/5/CEE (and subsequent amendments).

GENERAL SAFETY

WARNING! An incorrect installation or improper use of the product can cause damage to persons, animals or things.

- Scrap packing materials (plastic, cardboard, polystyrene etc) according to the provisions set out by current standards. Keep nylon or polystyrene bags out of children's reach.
- Keep the instructions together with the technical brochure for future reference.
- This product was exclusively designed and manufactured for the use specified in the present documentation. Any other use not specified in this documentation could damage the product and be dangerous.
- The Company declines all responsibility for any consequences resulting from improper use of the product, or use which is different from that expected and specified in the present documentation.
- Do not install the product in explosive atmosphere.
- Only use original parts for any maintenance or repair operation.
- Instruct the product user about the control systems provided and the manual opening operation in case of emergency.
- Keep radio control or other control devices out of children's reach, in order to avoid unintentional automation activation.
- The user must avoid any attempt to carry out work or repair on the automation system, and always request the assistance of qualified personnel.
- Anything which is not expressly provided for in the present instructions, is not allowed.

MAINTENANCE

System maintenance is to be regularly carried out by qualified personnel.

When the T-BOX unit's Red LED flashes after entering the correct code, it means the batteries are low. Repeat the installation procedure in reverse and have the batteries replaced.

DISPOSAL

ATTENTION: disposal should only be carried out by qualified personnel.

Materials must be disposed of in conformity with the current regulations. In case of disposal, the system components do not entail any particular risks or danger. In case of recovered materials, these should be sorted out by type (electrical components, copper, aluminium, plastic etc.)

The descriptions and illustrations contained in the present manual are not binding. The Company reserves the right to make any alterations deemed appropriate for the technical, manufacturing and commercial improvement of the product, while leaving its essential features unchanged, at any time and without undertaking to update the present publication.

1) GENERAL OUTLINE

The T-BOX is a 10-channel transmitter. Each channel is associated with a code to be typed on the keyboard.

The transmitter is powered by batteries, therefore no wired electrical connection is needed. The T-BOX is provided with touch keys; for any operation, it must be activated by means of the ON key. It can manage up to 100 different CODES (each CODE consists of a sequence of min. 4 and max. 7 figures) and up to 10 different activation CHANNELS, each CHANNEL corresponding to a different control unit installed (e.g. sliding gate

opening with channel 1 and overhead door opening with channel 2). The T-BOX has a sensor which, in case of poor light, activates keyboard lighting to make it easier to enter the code.

For reasons of system safety, in order to add an enabled code, it is necessary to enter a password (default 1234). Such password can be changed and must be remembered by the user.

WARNING: Keep the anti-tamper Allen key provided in the kit.

SIGNAL INDICATIONS

Signal Heard	Meaning
1 Short beep	Indicates that a key has been pressed
1 Long beep	Code entered correct/ memorisation on control unit
3 Short beeps	Code incorrect/error
RED led fixed after the correct code is entered	Battery exhausted

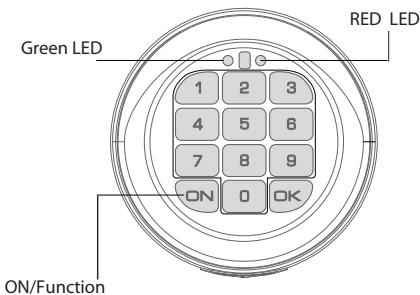

3) INSTALLATION (Fig.B points 1-6)

WARNING: think carefully about the installation site. Structures made from ferrous material could have an adverse effect on the T-BOX's operation.

4) MEMORIZING ON CONTROL UNIT/RECEIVER (Fig.C points 1-5).

To control a number of control units separately, use a different channel for each, entering the default codes. Once that is done, change the codes.

- Change 1111 to 56561
- Change 2222 to 56562
- Change 3333 to 56563

This makes it easier to remember the code as 5656 followed by the function number (1 for sliding gate, 2 for overhead door A, 3 for overhead door B), therefore:

- ON -> 56561 OK -> opens the sliding gate
- ON -> 56562 OK -> opens overhead door A
- ON -> 56563 OK -> opens overhead door B

5) TOTAL DELETION OF CODES (Fig.D points 1-5)

Following the total deletion of all codes, T-BOX will need to be memorized again on the control unit.

2) TECHNICAL SPECIFICATIONS

Batteries	2X CR123A min.1400mAh
Working temperature:	-10 +55 °C
No. of channels:	10
Frequency:	433.92 MHz
Transmission:	Rolling Code
Range:	100m in open field (*)
Degree of protection:	IP55
Dimensions	Fig. A

(*) The range can be affected by environmental and installation conditions.

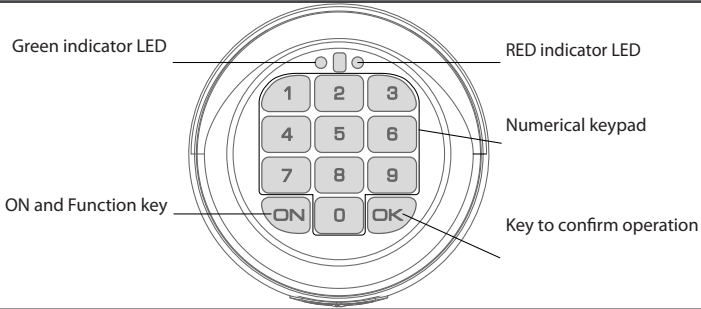

NORMAL USE

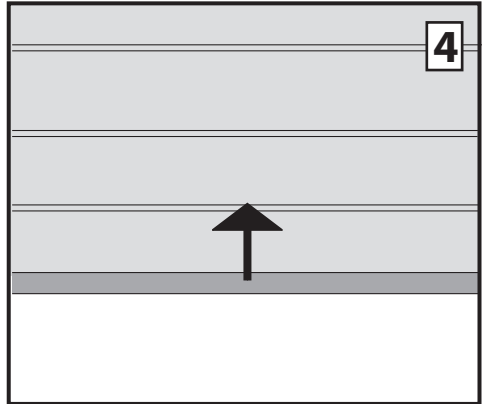
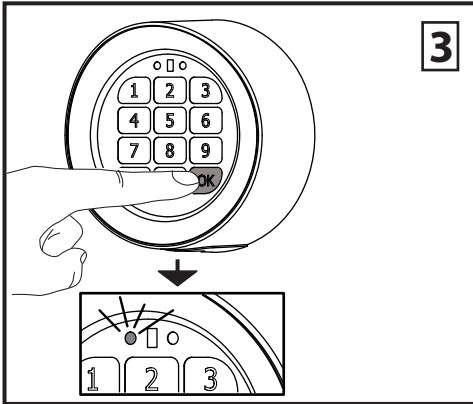
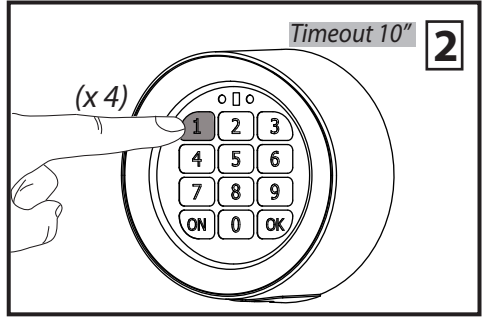
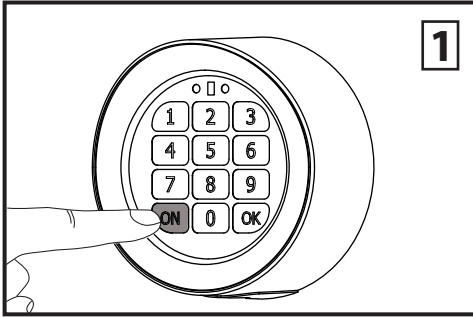

WARNING: T-BOX will lockout after 3 consecutive incorrect codes are entered and will not accept further codes for 90 seconds. If another incorrect code is entered, T-BOX will lockout at the first attempt.



DELETING A CODE

D811625 00100_01

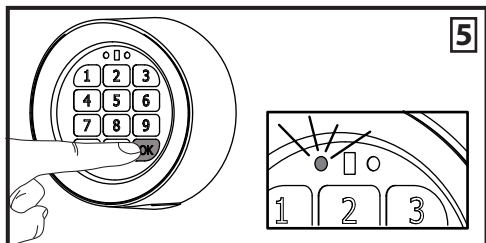
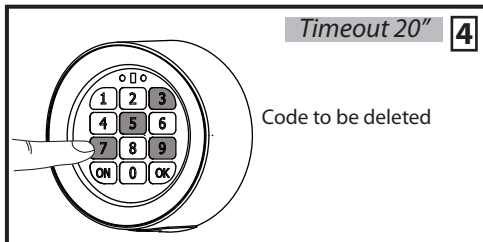
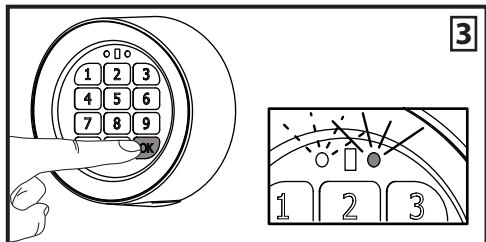
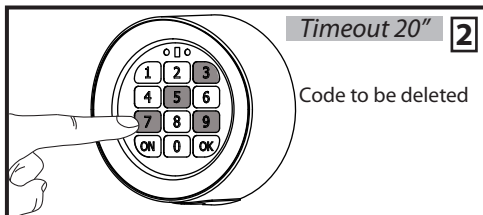
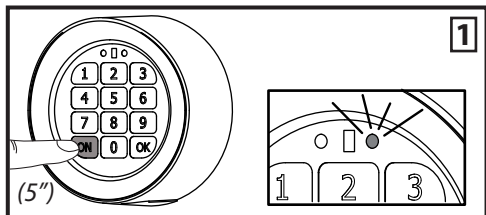

WARNING: if you delete the last code, you will no longer be able to activate the relevant control unit. To restore operation, you must perform the total deletion procedure to erase all codes and repeat installation from the beginning. It is advisable to delete the codes of channels that are not associated with anything (e.g. code 2222, 3333, 4444, 0000 etc. when using a single control unit).



ADDING A CODE

1 (5sec)

2 Timeout 20" Enter password

3

4 Timeout 20" (x4) Enter CH(eg.1111) to be activated.

5

6 Timeout 20" Enter new code

7

8 Timeout 20" Repeat new code

9 Code added!

WARNING: To add a code, you need to know the system password. T-BOX can handle up to 100 different codes. The new code will serve the same purpose as the existing code (activates the same channel).

CHANGING THE PASSWORD

D811625 00100_01

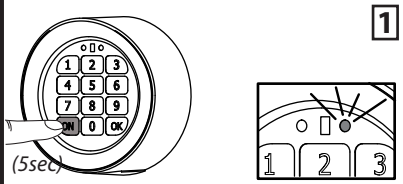
1  (5sec)

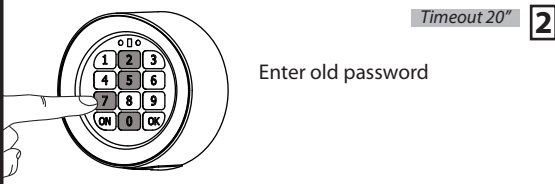
2 *Timeout 20"*  Enter old password

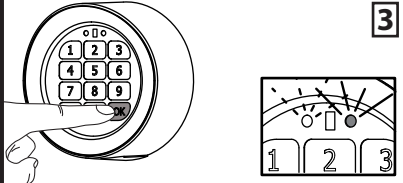
3  *Timeout 20"*

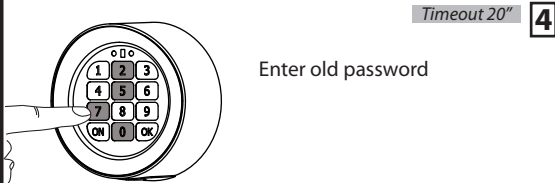
4 *Timeout 20"*  Enter old password

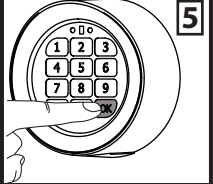
5 

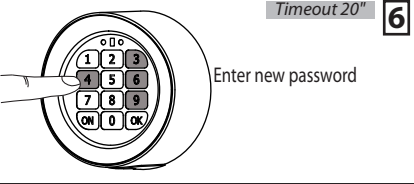
6 *Timeout 20"*  Enter new password

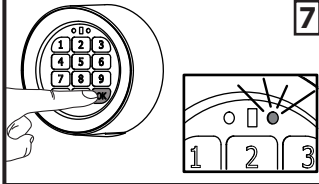
7 

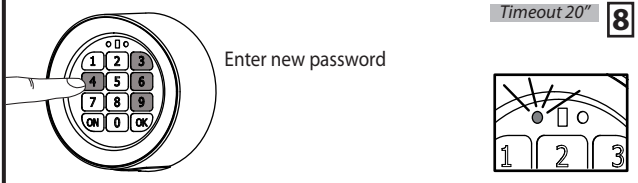
8 *Timeout 20"*  Enter new password

9  Password changed!

DEFAULT PASSWORD:

NEW PASSWORD:

:.....1234

.....

