

TRIPOD  
TURNSTILE

**TWISTER** SERIES



INSTALLATION MANUAL  
**PSBPS07**

English

EN

**EN**

# **WARNING!**

**Important instructions for the safety of people:**  
**READ CAREFULLY!**



## **Foreword**

• Use of the products must be restricted to its intended use (i.e. that for which it was expressly built for). Any other use is to be considered dangerous. CAME Cancelli Automatici S.p.A. is not liable for any damage resulting from improper, wrongful or unreasonable use • Keep these warnings with the installation and use manuals issued with the automated system.

## **Before installing**

*(preliminary check: in case of a negative outcome, do not proceed before having complied with the safety obligations)*

• Make sure that the parts you intend to automate are in good working order, and that they are properly balanced and aligned. Also, make sure that proper mechanical stops are already in place • If the operator will be installed at a height of less than 2.5 m from the ground or other access level, check whether you will need any protections and/or warnings • Any gate leaves, fitted with pedestrian entrances, onto which you will install an operator, must have a blocking mechanism when the gate is in motion • Make sure that the opening of the automated gate is not an entrapment hazard as regards any surrounding fixed parts • Do not mount the operator upside down or onto any elements that may fold under its weight. If needed, add suitable reinforcements at the points where it is secured • Do not install onto gates on either an upward or downward slope (i.e. that are not on flat, level ground) • Check that any lawn watering devices will not wet the gearmotor from the bottom up.

## **Installation**

• Carefully section off the entire site to prevent unauthorised access, especially by minors and children • Be careful when handling operators that weigh more than 20 Kg (see installation manual). In such cases, employ proper weight handling safety equipment • All opening commands (e.g. buttons, key selectors, magnetic detectors, etc.) must be installed at least 1.85 m from the gate's area of operation perimeter - or where they cannot be reached from the outside of the gate. Also, the direct commands (e.g. push button, or proximity devices, etc.) must be installed at a height of at least 1.5 m and must not be accessible to the public • All 'maintained action' commands, must be placed where the moving gate leaves, transit areas and driveways are completely visible • If missing, apply a permanent label that shows the position of the release mechanism • Before delivering to the client, verify that the system is EN 12453 (impact test) standard compliant. Make sure that the operator has been properly adjusted and that the safety and protection devices, as well as the manual release

are working properly • Where necessary and in plain sight, apply the Warning Signs (e.g. gate plate).

## **Special instructions and advice for users**

• Keep the gate's area of operation clean and clear of any obstacles. Trim any vegetation that may interfere with the photocells • Do not allow children to play with the fixed command devices, or in the gate's area of operation. Keep any remote control devices (i.e. transmitters) away from the children as well • Frequently check the system, to see whether any anomalies or signs of wear and tear appear on the moving parts, on the component parts, on the securing points, on the cables and any accessible connections. Keep any joints (i.e. hinges) lubricated and clean, and do the same where friction may occur (i.e. slide rails) • Perform functional tests on photocells and sensitive edges, every six months. Keep glass panels constantly clean (use a slightly water-moistened cloth; do not use solvents or any other chemical products) • If the system requires repairs or modifications, release the operator and do not use it until safety conditions have been restored • Cut off the power supply before releasing the operator for manual openings. See instructions • Users are FORBIDDEN to carry out ANY ACTIONS THAT THEY HAVE NOT BEEN EXPRESSLY ASKED TO DO OR SO INDICATED in the manuals. Any repairs, modifications to the settings and extraordinary maintenance MUST BE DONE BY THE TECHNICAL ASSISTANCE STAFF • On the periodic maintenance log, note down the checks you have done.

## **Special instructions and advice for all**

• Avoid working near the hinges or moving mechanical parts • Stay clear of the gate's area of operation when in motion • Do not resist the direction of movement of the gate; this may present a safety hazard • At all times be extremely careful about dangerous points that must be indicated by proper pictograms and/or black and yellow stripes • When using a selector or command in 'maintained action' mode, keep checking that there are no people in the area of operation of the moving parts. Do this until you release the command • The gate may move at any time without warning • Always cut the power when cleaning performing maintenance.



**CAME cancelli automatici s.p.a.**  
Via Martiri della Libertà, 15  
31030 Dosson di Casier  
TREVISO - ITALY  
[www.came.it](http://www.came.it) - [info@came.it](mailto:info@came.it)

# General conditions of sale



## 1. GENERAL POINTS

These general conditions shall apply to all purchase agreements for Came Cancelli Automatici SpA materials, hereinafter called “the company”.

## 2. OFFERS AND QUOTATIONS

The company's quotations are valid for a 30-day period at the most starting from the date they are sent.

## 3. ORDERS

The sale agreement is executed once the written order is confirmed by Came Cancelli Automatici Spa or when the order is fulfilled by the company. Orders that are addressed, and signed by clients, to Came Cancelli Automatici SpA are deemed to be firm and irrevocable for 30 days starting from the date they are received by the company. Any change or addition to the single provisions of these general conditions or single provisions of the order which was originally addressed by the client, shall have no validity unless otherwise approved in writing by the company. For any changes to the order, the company reserves the right to cancel both the changes and the original order. The delivery date for the goods appearing on the orders is always and in any case exclusively indicative, and any delays of such term may never justify claims for compensation or cancellation of contract.

Particularly, the company reserves the right to extend the delivery terms or cancellation of order in the event of: force majeure or events that are beyond the control of the company; change of the Client's legal status; difficulty in sourcing raw materials and component parts.

## 4. DELIVERY AND FORWARDING

The place of production or registered office of the company shall be the place of fulfilment for delivery. The cost and risk of the travelling goods is borne by the buyer ex works, pursuant to the 2000 incoterms. Unless otherwise agreed, the company establishes, for and on behalf of the client, the type of shipping, the travel route and type of carrier. The company reserves the right to carry out partial deliveries and fulfilment of orders, thereby issuing a separate invoice each time: in this case all partial deliveries shall be autonomously invoiced and the terms of payment shall begin as of the date on each invoice; the client may not, therefore, defer payment of partial orders, until the last delivery is made as concerns the original order.

## 5. PRICES AND PRICE LISTS

The prices are intended for goods delivered free to the company's registered office, not including VAT, with normal packaging, and not including forwarding expenses. Any reference to list prices shall refer to the latest price list published by the company, which theretofore cancels any previous price lists.

## 6. PAYMENTS

Non-payment within the established terms, shall result in the application of interest pursuant to Lgs. Decr. 09/10/2002 n. 231 and subsequent amendments and upgrades, with any possible greater damage unprejudiced. Any delay in payment, shall mean that the client shall owe the company, any losses due to exchange rates. The client may not advance any demands nor raise any exceptions as concerns the company, unless after having paid the goods it purchased. The company reserves the right to block all shipping and supply orders underway in the face of any irregularities in the payments, without need of prior notice nor compensatory damages of any kind.

## 7. RETURNS AND CLAIMS

All claims must be filed in writing within 8 days of receiving the goods, whether such claims refer to the quantity or quality of the delivered goods. Returned goods shall be accepted by company only following a written agreement, and only for new and packaged goods. Any returned goods must be complete of their relative transport documents, showing the company's written authorisation to accept the returned goods including the quality and quantity of the returned goods.

The returned goods shall not be accepted by the company unless carried out in the above mentioned manner and, especially, returned goods shall not be accepted if received at any of the company's premises.

## 8. GUARANTEE

The company guarantees the proper functioning of the products that it provides, as per the technical characteristics that are expressly shown on its products' technical sheets. The guarantee shall not apply in the case of any environmental interferences of any nature, which could cause disturbances in the functioning of any existing or future installations (radio frequencies – proximity of electric power lines...). The guarantee does not cover the normal wear and tear of the equipment, or mistakes made during the mounting phase or due to maintenance flaws, and in any case it does not cover any cases in which flaws in the functioning can be traced back to factors stemming from anything other than manufacturing.

The deadlines for filing a claim for any flaws or for the statute of limitations for actions to which the buyer is entitled are those foreseen by Italian law. The company at its own leisure, may decide to withdraw any goods supplied which it has ascertained as faulty, or decide to repair said ascertained flaws. The client may not request to be compensated for any indirect damages, missed gains, production losses, and in any case may not expect as compensation any sums greater than the value of the supplied components or products.

## 9. REPAIRS

Repairs to purchased items request by the client shall be carried out by the company following an agreement on the price of said repairs. In any case the expenses for labour and shipping (roundtrip) shall be borne by the client.

## 10. RESERVATION OF TITLE

It is expressly agreed that, any delivered goods remain owned by the company until the client pays the entire balance, regardless of who is in possession of said goods. Transport expenses and any other expenses needed to retrieve the equipment, therein including any extraordinary expenses as well as any repeatable ones, shall be borne by the client.

**11. APPLICABLE LAW – SETTLEMENT OF ANY DISPUTES** Any arising dispute resulting from the sale agreement, shall be settled according to the Italian law, thereby excluding any other law and in supplement to the Vienna Convention on the international sale of goods. All disputes shall be subject to Italian jurisdiction and come under the exclusive competence of the Tribunal of Treviso, Italy.

## 12. PROVISIONS ON THE SAFEGUARDING OF PERSONAL DATA.

Pursuant to current legislation for the safeguarding of personal data, clients are aware that their personal data is inputted into the company's databank, which is necessary for the proper carrying out of the contractual relationship and for compliance with certain provisions of law, as well as for purposes of statistics, promotion, marketing, commercial, credit protection, management and transfer of the same.

The personal data of the buying party are processed through automated and paper-based tools by authorised persons, by using safety procedures designed to guarantee confidentiality. The personal data of the client may be shared with Public Bodies, companies of the group, credit recovery firms, or consortiums or associations with business scopes, market research scopes, or marketing scopes. The data processor shall be the company, and the client may address said company to uphold their own rights as per law. To this end the buying party is aware that at any time it may access its personal data, ask that it be updated, corrected and/or prohibit it from being used.

## “IMPORTANT SAFETY INSTRUCTIONS FOR INSTALLATION”

“WARNING: WRONG INSTALLATION MAY CAUSE SERIOUS INJURY, FOLLOW ALL INSTALLATION INSTRUCTIONS”

“THIS MANUAL IS EXCLUSIVELY MEANT FOR PROFESSIONAL INSTALLERS OR OTHER COMPETENT PERSONS”

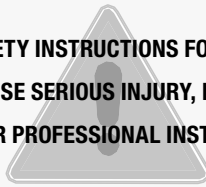

## 1 Legend of symbols

- This symbol shows parts to be read carefully.
- This symbol shows parts related to safety.
- This symbol shows what to tell users.

## 2 Conditions of use

### 2.1 Intended use

The TWISTER electromechanical turnstile is designed to select transit flows in high-volume passage areas, and in highly frequented contexts like stadiums, airports, stations, public buildings and in any other places where high-volume flows need to be regulated and/or selected.

- Any installation or use other than that shown in this manual is prohibited.

## 3 Reference Legislation

The product being described herein complies with the following legislation: see compliance statement.

## 4 Description

### 4.1 Turnstile

This product is designed and built by CAME Cancelli Automatici S.p.A. in compliance with the current safety legislation.

Guaranteed 24 months unless tampered with.

Selective, bidirectional, electromechanical turnstile, entirely made of AISI 304 stainless steel with “scotch-brite” finish, fitted with a removable top cover with key lock, and removable side legs. The aluminium tripod head bears a shiny finish and stainless steel, shiny-polished arms.

It works by allowing only one person to transit through in the desired direction. A command on the device releases the mechanism to manually push the tripod arm until the mechanical brake slows the tripod down to its resting position, until a new command is given.

### 4.2 Technical Data and dimensions

PSBPS07

Power: 230V A.C. 50/60 Hz

Power Draw: 500 mA max

Insulation class: II

Protection rating: IP44

Weight: 60 Kg

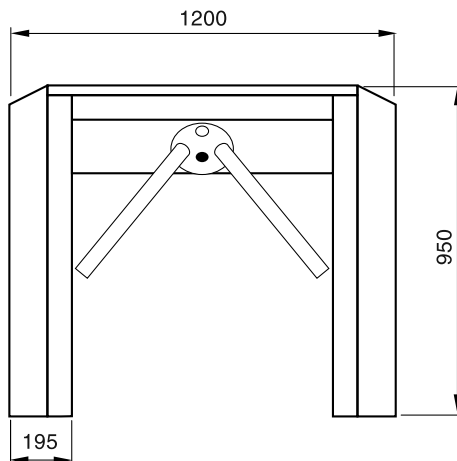
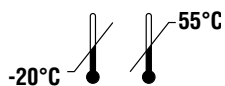

Suggested distance between one turnstile and another in case of multiple installation.

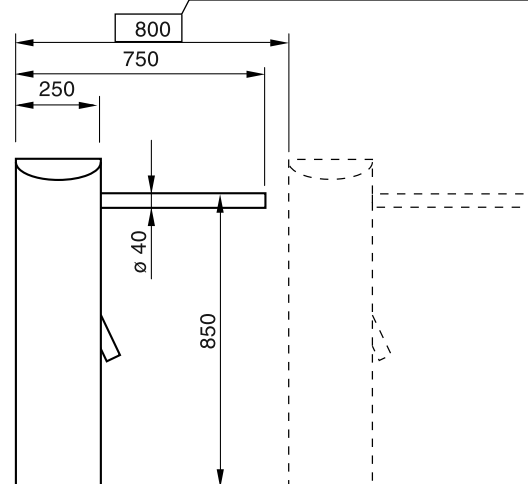

## 5 Application examples

**⚠ Warning: an exit fitted with a turnstile cannot be an emergency exit. There must always also be an emergency exit for physically impaired persons.**

Standard installation

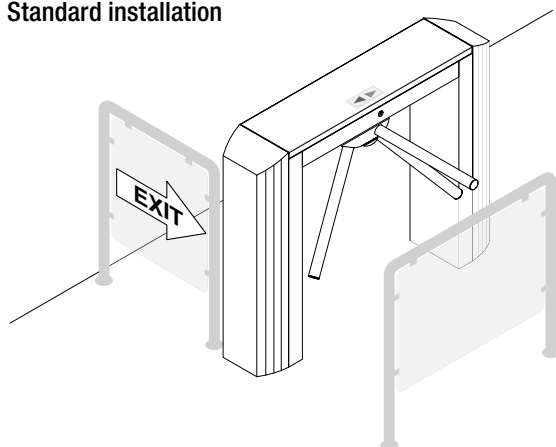

Against the wall installation

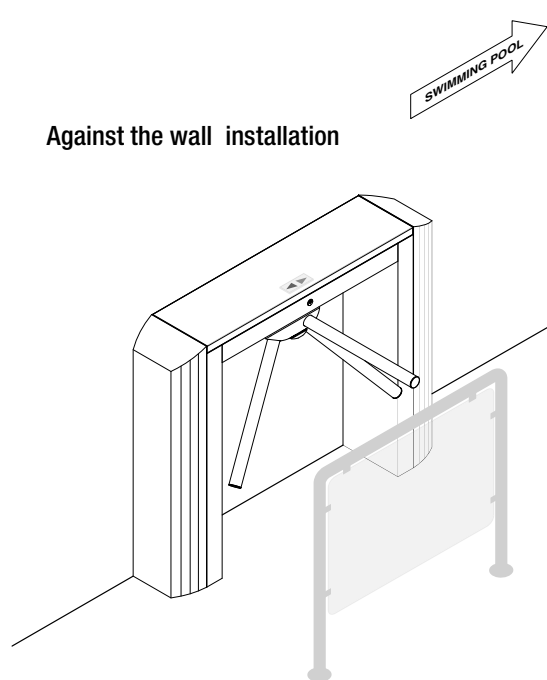

Multiple installation

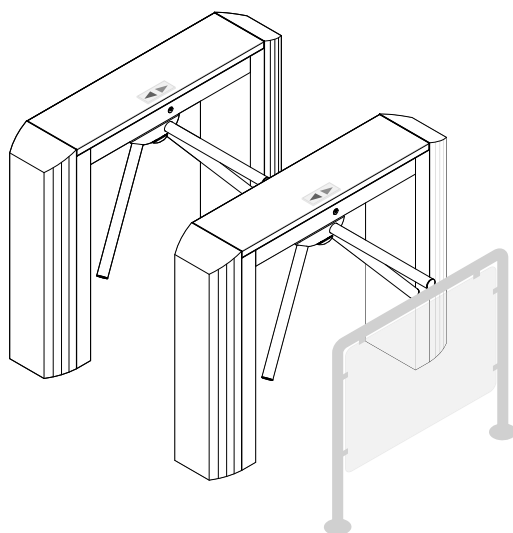

Platform installation

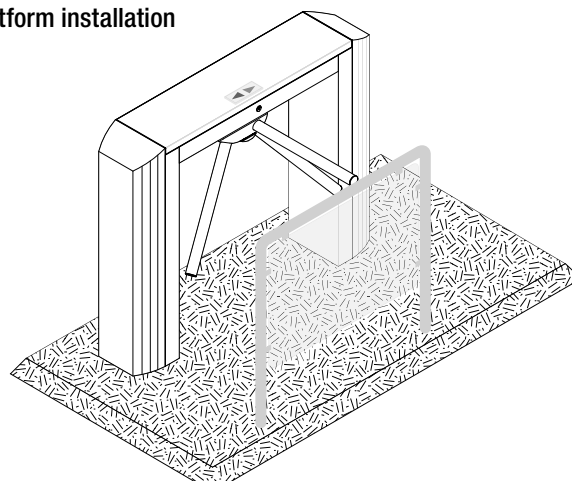

## 6 Installation

**⚠ Only skilled, qualified staff must perform the installation, in full compliance of the current legislation.**

**⚠ Before installing the automated device, please:**

- Set up a proper omnipolar cut-off device, with contacts more than 3 mm apart, and power source isolation;
- Set up proper tubing and conduits for the electrical cables to go through with enough protection from any mechanical damage;
- ⚡ Check that any connections within the container (made to give continuity to the protection circuit) have additional isolation compared to the other internal power conductors.

### 6.1 Tools and equipment

Make sure you have all the tools and materials needed to carry out the installation in total safety and in compliance with current legislation. The figures shows examples of installers' tools.

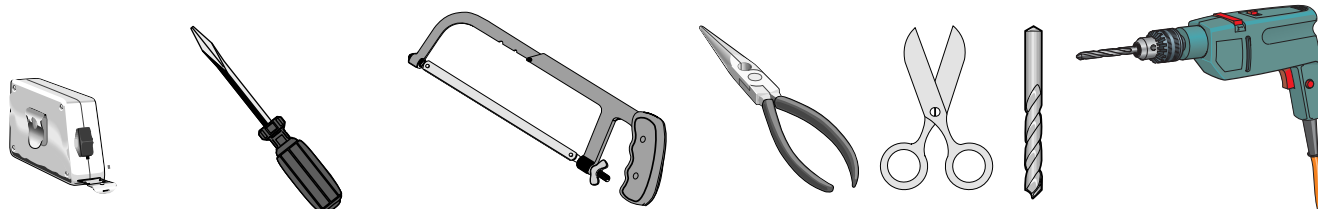

## 6.2 Positioning the turnstile

Depending on the measurements of the transit opening, choose where to position the turnstile and any accessories.  
Set up electrical cable conduits next to the turnstile.  
If the floor cannot be dug, then use the (TRPE) platform to secure the turnstile and any accessories.

## 6.3 Disassembling and securing the turnstile to the ground

**⚠ Warning: installation required two people. Use hoisting equipment to move and position the turnstile. When securing, the turnstile may be unstable and could tip over, so be careful not to lean onto it until securing is complete.**

Use the issued key to release the lock on the front of the turnstile and remove the upper cover.

**⚠ Warning: when opening the cover be careful not to rip the display cables. You may have to disconnect them.**

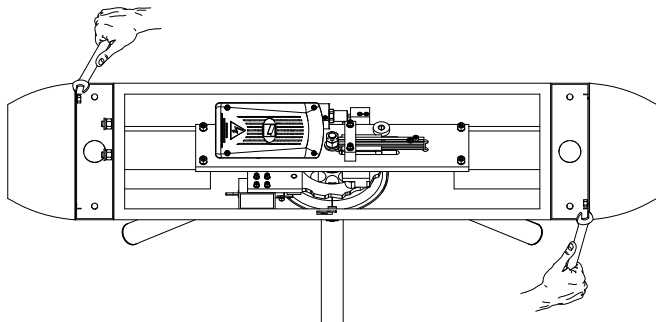
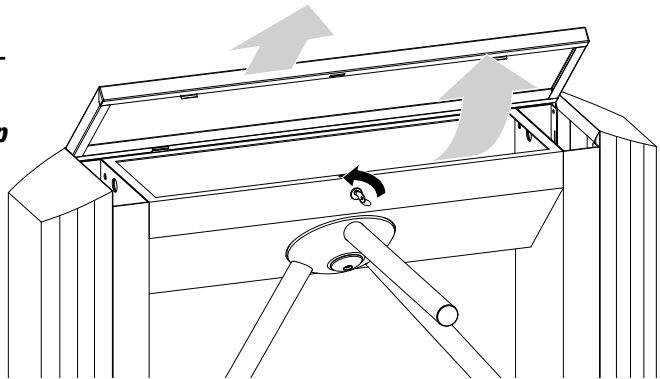

Remove screws from the carters.

Remove the casings as shown in the figure. Lightly lift to unhook the casing and then remove it.

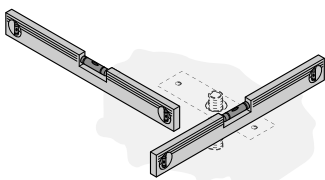
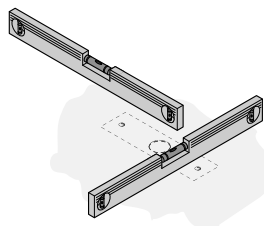
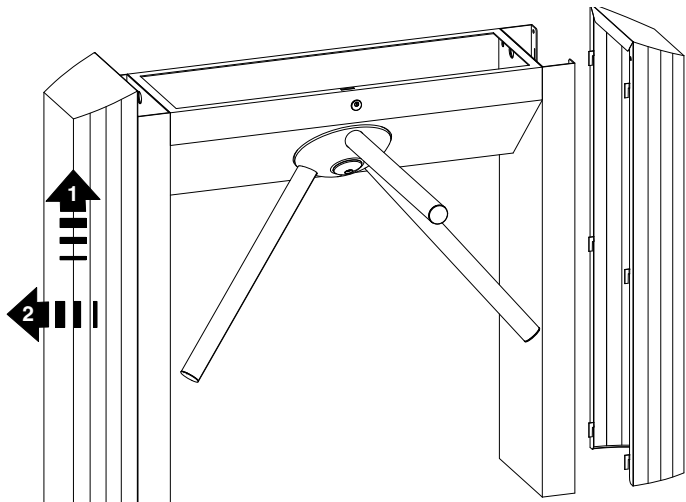

Check that the floor where the turnstile is anchored is level and without warping.

Position the turnstile in the exact point where it will be anchored and mark the holes with a pencil.

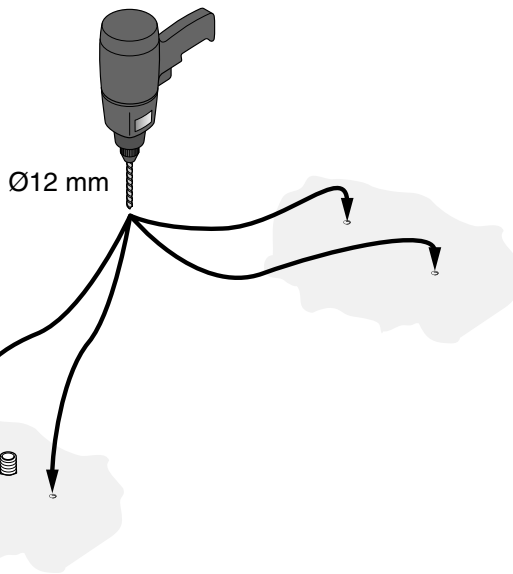
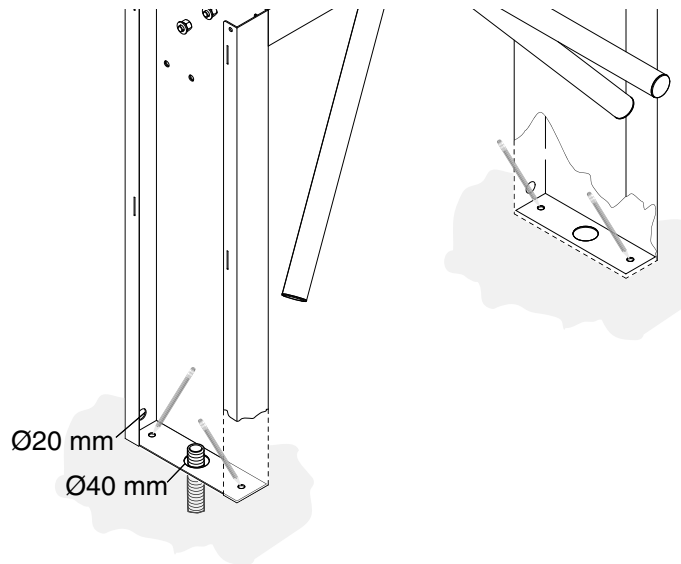

Remove the turnstile and apply (Ø 12mm) holes where you have marked them.

Insert the Ø 12mm, minimum length 50 mm gussets into the holes you have made.  
Position the turnstile along the gussets and run any cable conduits through the central hole.  
Using a ratching driver, secure the turnstile to the ground.

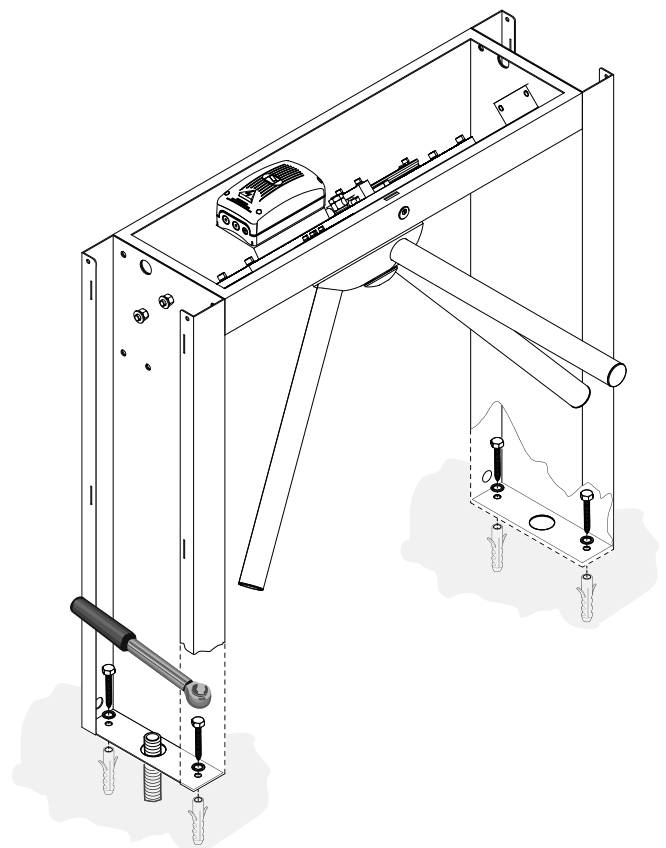

## 7 Electric cabling

Once the turnstile is secured to the ground, carry out the following cable connections. Run through the conduits as shown in the figure and carry out the shown connections.

**The cables inserted into the electrical panel box must be secured using the opposite cable gland.**

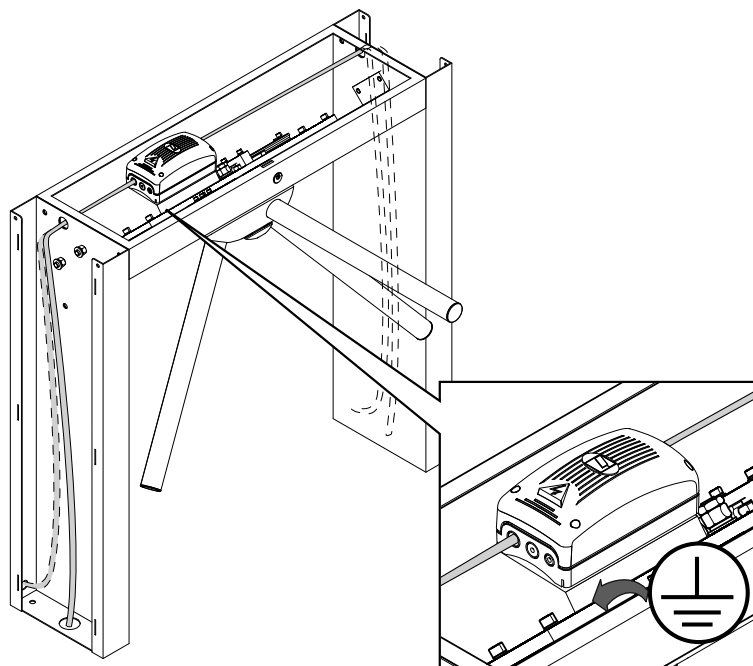
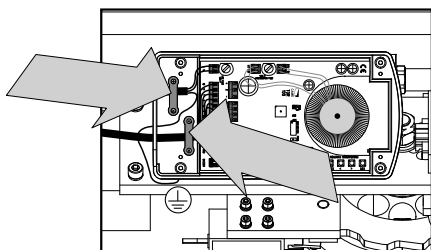

### 7.1 Cable types and sections

Connections	Cable types	Cable length 1 < 10 m	Cable length 10 < 20 m	Cable length 20 < 30 m
Power to electrical panel 230V	FROR CEI 20-22	3G x 1,5 mm <sup>2</sup>	3G x 2,5 mm <sup>2</sup>	3G x 4 mm <sup>2</sup>
Power to accessories		2 x 0,5 mm <sup>2</sup>	2 x 0,5 mm <sup>2</sup>	2 x 1 mm <sup>2</sup>
Command and safety devices	CEI EN 50267-2-1	2 x 0,5 mm <sup>2</sup>	2 x 0,5 mm <sup>2</sup>	2 x 0,5 mm <sup>2</sup>

*N.B. If the cable length differs to that shown in the table, determine cable section based on the actual power draw by the connected devices and according to what is prescribed by law CEI EN 60304-1.*

*For sequential connections on the same line, length-measurements by the table must be converted on the basis of draw and actual distances.*

*To connect any products not mentioned in this manual, see documentation provided with said products.*

## 8 control panel

### 8.1 General description

The control panel is powered by 230V A.C. on terminals L-N, with max frequency of 50/60Hz.

**The 24V current emitted by the board is of the SELV type.**

The command and control devices and accessories are 24V D.C..  
Warning! The accessories must not comprehensively exceed 35W.

All connections are quick-fuse protected, see table.

The functions and user interface are set and displayed on the software-managed display.

The definable command and control functionalities are:

- clock-wise activation;
- counter clock-wise activation;
- override release command;
- emergency command.

**WARNING:** before doing any work inside the equipment, cut the power mains.

**FUSE TABLE**

To protect:	Fuse rating:
Control board (line)	1,6A-F
Accessories	1,6A-F



## 8.2 Main Components

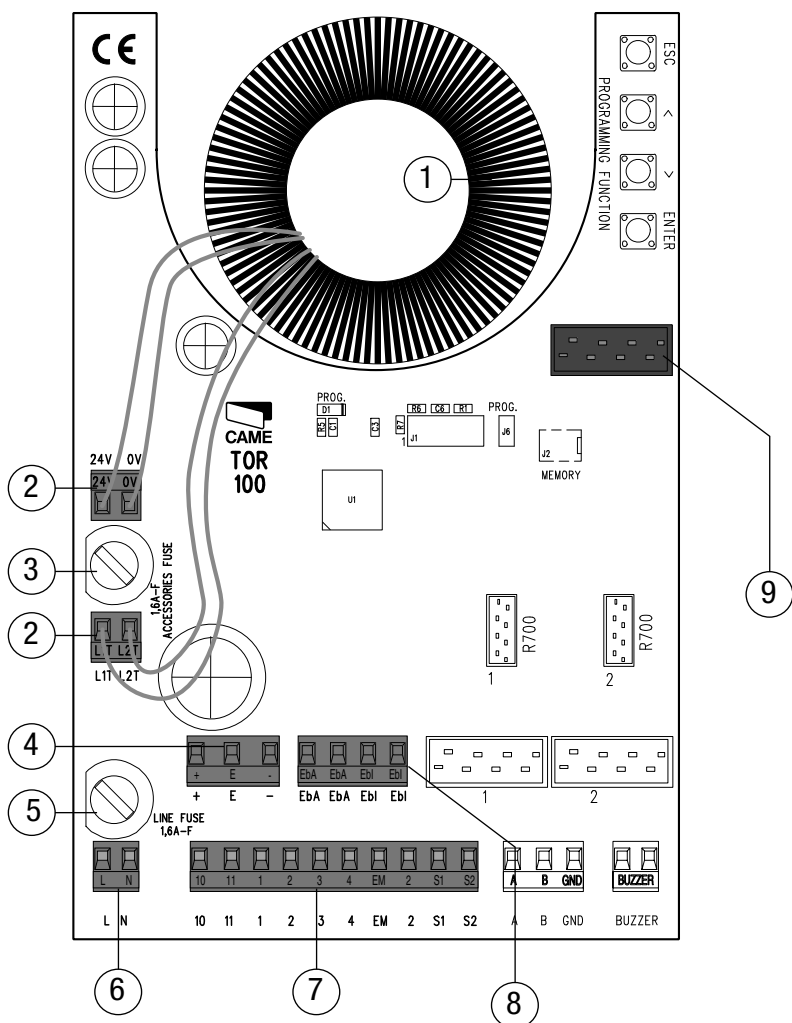

1. Transformer
2. Transformer connection terminals
3. 1.6A accessories Fuse
4. Endpoint connection terminal
5. 1.6A line fuse
6. 230V A.C. control board power terminals
7. Terminals for connecting accessories and command and control systems.
8. Electro-block connection terminal board
9. Stop/Go lights connection terminal board (optional)

## 9 Electrical connections

### 9.1 Power

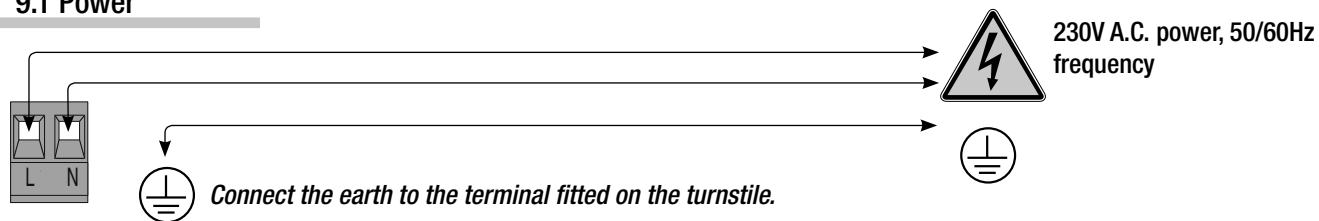

### 9.2 Connecting devices to the control panel

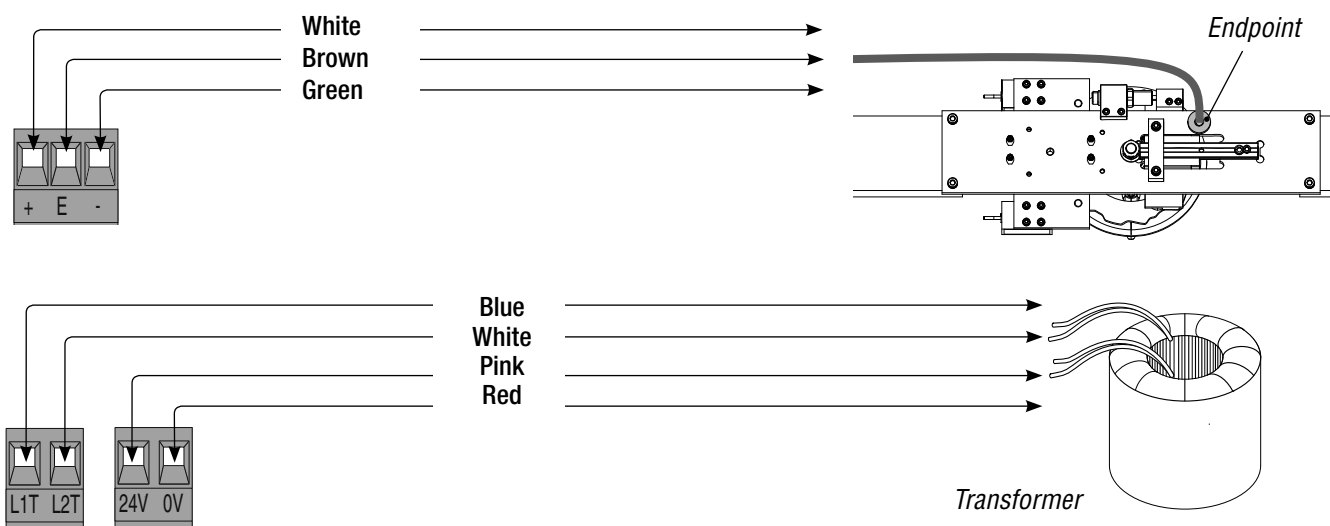

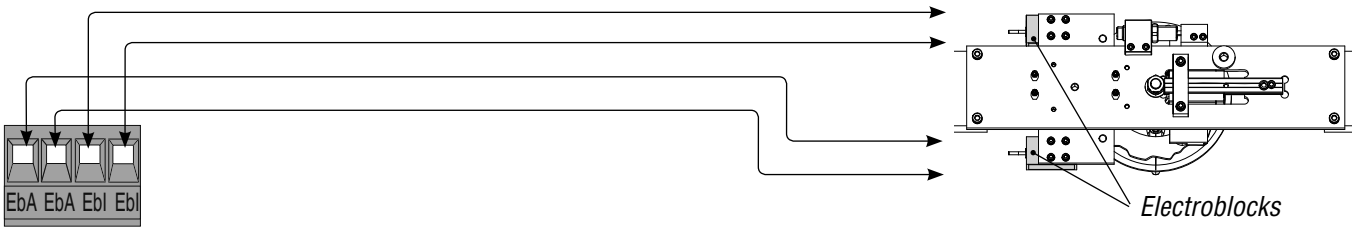

### 9.3 Connecting optional devices to the control panel

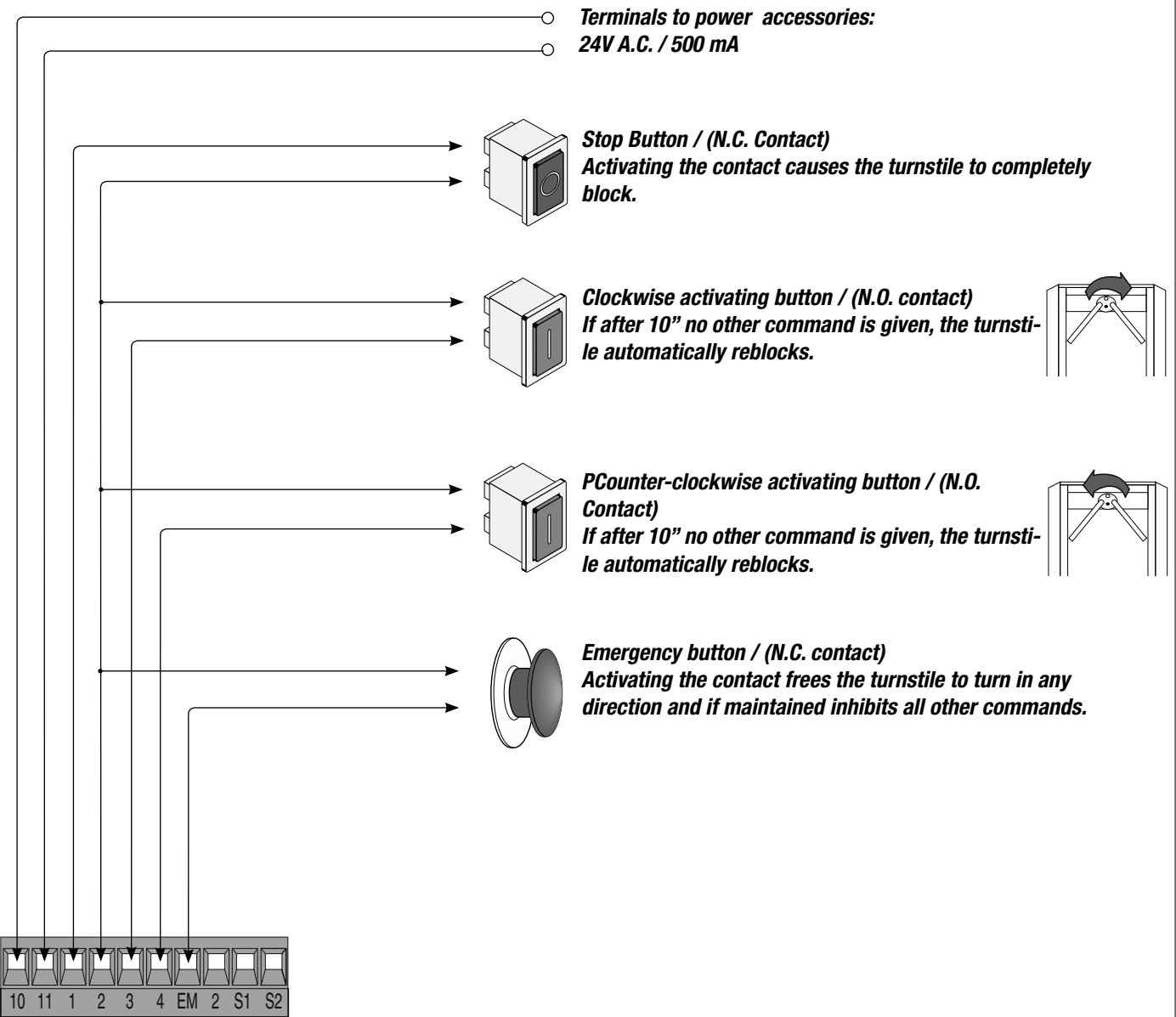

## 9.4 Connecting optional anti-intrusion devices to the control panel

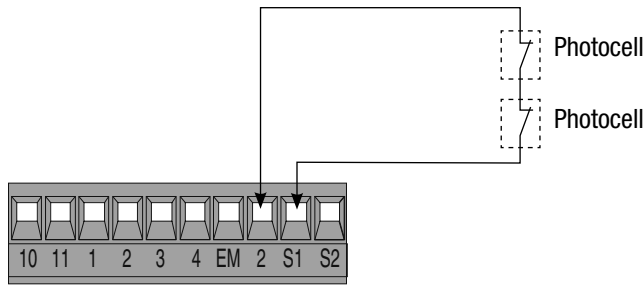

### **Anti-intrusion photocell (N.C. contact)**

Anti-intrusion sensors placed in line with the passage way, activate a Buzzer, in case of any climb-over attempts.

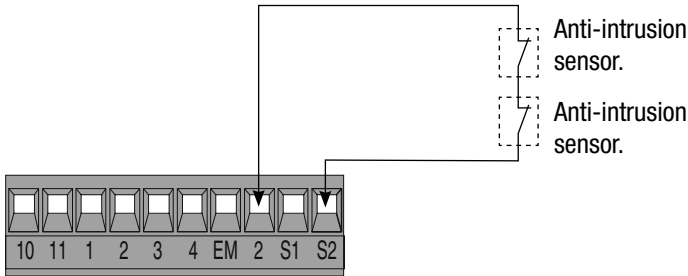

### **Pressure sensor / (N.C. contact)**

Anti-intrusion sensors placed under the turnstile's top cover, which activate the Buzzer, in case of any climb-over attempts.

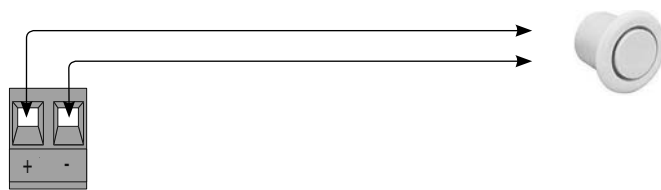

### **Buzzer**

Alarm buzzer activated by anti-intrusion devices in case of any climb-over attempts.  
Contact output: 12V D.C. – 100mA

**⚠ Once the power is connected, wait 10 seconds before proceeding with any operations.**

## 10 Safety instruction

**⚠ Warning: opening the turnstile only 60° will cause the tripod to automatically return.**

**Warning: by leaning on the tripod arm before it is released, the release will not take place and the turnstile will stay closed.**

### **⚠ Important general safety instructions**

This product must be only used for its specific intended purpose. Any other use is wrongful and therefore dangerous. The manufacturer is not liable for any harm or damage caused by improper, wrongful or unreasonable use.



Danger voltage running through parts



Impact danger



Transit prohibited during operation.

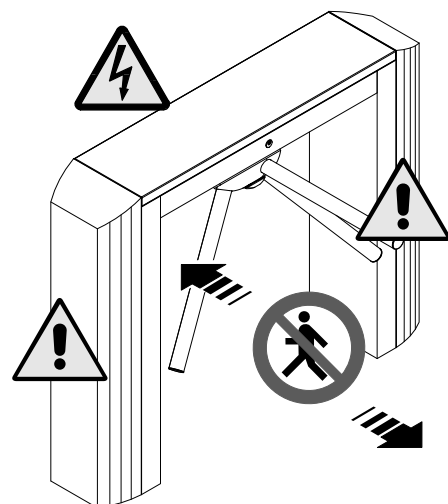

Do not allow children to play or loiter in the operating range of the turnstile.

Keep command and control devices out of reach of children, to prevent the turnstile from being accidentally activated.

Immediately suspend use of the turnstile if any anomalies are manifested.

# 11 Maintenance

## 11.1 Periodic maintenance

- Carry out the following periodic maintenance:  
Check turnstile's internal cabling, check that cables are not disconnected or damaged.  
By turning the tripod, check for any faulty movements and that the rotation is homogenous.  
A sudden blocking may indicate a malfunction.  
By trying to move it, try to properly secure the turnstile to the ground, because unstable securing can result in danger.

**Do not clean the turnstile with chemical products that may damage the stainless steel, do not use abrasive substances or rags that may scratch the surface.**

## 11.2 Trouble shooting

DISFUNCTIONS	POSSIBLE CAUSES	CHECKS AND REMEDIES
The turnstile stays released in both directions of travel	<ul style="list-style-type: none"><li>No power</li><li>Stop button is stuck or broken</li><li>Emergency button is pressed</li><li>Electroblocks are not working.</li></ul>	<ul style="list-style-type: none"><li>Check power source</li><li>Call assistance</li><li>Reload the emergency button</li><li>Call assistance</li></ul>
The turnstile only releases in one direction	<ul style="list-style-type: none"><li>One of the electroblock is broken down</li><li>The spring of one of the electroblocks has become disconnected</li></ul>	<ul style="list-style-type: none"><li>Call assistance</li><li>Call assistance</li></ul>
The turnstile stays blocked	<ul style="list-style-type: none"><li>The person passing through leaned on the arm before the release took place.</li><li>Both electroblocks stay wound up</li></ul>	<ul style="list-style-type: none"><li>Tell the person not to lean on the arm and try to release</li><li>Call assistance</li></ul>
The turnstile blocks suddenly	<ul style="list-style-type: none"><li>The hydraulic brake is not working properly</li></ul>	<ul style="list-style-type: none"><li>Call assistance</li></ul>

# 12 De-commissioning and disposal

Came Cancelli Automatici company is ISO 9001:2000 certified for its in-house quality system and ISO 14001 certified in terms of its environmental practices. We kindly ask you to keep on respecting the environment – CAME considers this one of the fundamentals of its own development and market operation strategies, by simply following these brief disposal instructions:

### DISPOSING OF THE PACKAGING

The packaging components (cardboard, plastic, etc.) are considered solid urban waste and may be disposed without any trouble in the proper recycling bins supplied by your municipality.

### DO NOT DISPOSE OF IN THE ENVIRONMENT

### DISPOSING OF THE PRODUCT

Our products are made with different materials. The majority of these (i.e. aluminium, plastic, iron, electrical cables) consist of solid urban waste. They can be recycled at authorised recycling centres. Other components (electronic boards, remote control batteries, etc.) may contain toxic substances.

They must therefore be removed and turned into authorised firms that will dispose of them properly. Before proceeding it is always best to check the specific legislation in your municipality.

### DO NOT DISPOSE OF IN THE

# 13 Declaration



## MANUFACTURER'S STATEMENT

Pursuant to Low Voltage Directive 2006/95/CE



CAME Cancelli Automatici S.p.A.  
via Martiri della Libertà, 15  
31030 Dosson di Casier - Treviso - ITALY  
tel (+39) 0422 4940 - fax (+39) 0422 4941  
internet: www.came.it - e-mail: info@came.it

**IMPORTANT WARNING!**  
**It is prohibited to operate the product/s described in this declaration, before it is entirely complete and/or incorporated in compliance with what is set forth by Machine Directive 98/37/CE**

Hereby states under its own liability, that these products to automate gates, and garage doors, called:

### TWISTER

comply with the essential requirements and pertinent directives and the applicable parts of the reference legislation listed below.

MANAGING DIRECTOR  
Mr Gianni Michielan

2006/95/CE  
2004/108/CE

LOW VOLTAGE DIRECTIVE  
ELECTROMAGNETIC COMPATABILITY DIRECTIVE

EN 13241-1  
EN 60335-1

EN 61000-6-2  
EN 61000-6-3

---

Reference code to request a facsimile: DDF L EN 0001A

---

**CAME France S.a.**  
7, Rue Des Haras  
Z.i. Des Hautes Patures  
92737 **Nanterre Cedex** - FRANCE  
☎ (+33) 1 46 13 05 05  
✉ (+33) 1 46 13 05 00

**CAME Gmbh Seefeld**  
Akazienstrasse, 9  
16356 **Seefeld**  
Bei Berlin - DEUTSCHLAND  
☎ (+49) 33 3988390  
✉ (+49) 33 39883985

**CAME Automatismes S.a.**  
3, Rue Odette Jasse  
13015 **Marseille** - FRANCE  
☎ (+33) 4 95 06 33 70  
✉ (+33) 4 91 60 69 05

**CAME Gmbh**  
Kornwestheimer Str. 37  
70825 **Korntal**  
Munchingen Bei Stuttgart - DEUTSCHLAND  
☎ (+49) 71 5037830  
✉ (+49) 71 50378383

**CAME Automatismos S.a.**  
C/juan De Mariana, N. 17-local  
28045 **Madrid** - SPAIN  
☎ (+34) 91 52 85 009  
✉ (+34) 91 46 85 442

**CAME Americas Automation Llc**  
1560 Sawgrass Corporate Pkwy, 4th Floor  
**Sunrise, FL 33323** - U.S.A  
☎ (+1) 305 433 3307  
✉ (+1) 305 396 3331

**CAME Automatismos Catalunya S.a.**  
Pi. Moli Dels Frares N. 23 C/a  
08620 **Sant Vicenc Del Horts** - SPAIN  
☎ (+34) 93 65 67 694  
✉ (+34) 93 67 24 505

**CAME Middle East Fzco**  
Po Box 17131 Warehouse N. Be02  
South Zone - Jebel Ali Free Zone - **Dubai** - U.A.E.  
☎ (+971) 4 8860046  
✉ (+971) 4 8860048

**Paf - CAME**  
Estrada Nacional 249-4 Ao Km 4,35  
Cabra Figa - Trajouce  
2635-047 **Rio De Mouro** - PORTUGAL  
☎ (+351) 219 257 471  
✉ (+35) 219 257 485

**CAME Polska Sp.Zo.o**  
Ul. Ordona 1  
01-237 **Warszawa** - POLAND  
☎ (+48) 22 8365076  
✉ (+48) 22 8363296

**CAME United Kingdom Ltd.**  
Unit 3 Orchard Business Park  
Town Street, Sandiacre  
**Nottingham** - Ng10 5du - UNITED KINGDOM  
☎ (+44) 115 9210430  
✉ (+44) 115 9210431

**S.c. CAME Romania S.r.l.**  
B-dul Mihai Eminescu, Nr. 2, Bloc R2  
Scara A, Parter, Ap. 3  
Buftea, Judet Ilfov **Bucarest** - ROMANIA  
☎ (+40) 21 3007344  
✉ (+40) 21 3007344

**CAME Belgium Sprl**  
Zoning Ouest 7  
7860 **Lessines** - BELGIUM  
☎ (+32) 68 333014  
✉ (+32) 68 338019

**CAME Russia**  
Leningradskij Prospekt, Dom 80  
Pod'ezd 3, office 608  
125190, **Moskva** - RUSSIA  
☎ (+7) 495 937 33 07  
✉ (+7) 495 937 33 08

English - Manual code: 119G3072 ver. 0.1 02/2009 © CAME cancelli automatici s.p.a. The data and information reported in this installation manual are susceptible to change at any time and without obligation on CAME cancelli automatici s.p.a. to notify users.



**CAME Cancelli Automatici S.p.a.**  
Via Martiri Della Libertà, 15  
31030 **Dosson Di Casier (Tv)**  
☎ (+39) 0422 4940  
✉ (+39) 0422 4941  
Informazioni Commerciali 800 848095  
www.came.it

**CAME Nord s.r.l.**  
Piazza Castello, 16  
20093 **Cologno Monzese (MI)**  
☎ (+39) 02 26708293  
✉ (+39) 02 25490288

**CAME Service Italia S.r.l.**  
Via Della Pace, 28  
31030 **Dosson Di Casier (Tv)**  
☎ (+39) 0422 383532  
✉ (+39) 0422 490044  
**Assistenza Tecnica 800 295830**

**CAME Sud s.r.l.**  
Via F. Imperato, 198  
Cm2 Lotto A/7  
80146 **Napoli**  
☎ (+39) 081 7524455  
✉ (+39) 081 7529109